

Road Transport (Dimensions and Mass) B-Double Exemption Notice 2004

Disallowable Instrument DI 2004—74

made under the

Road Transport (Dimensions and Mass Act 1990), Section 31A (Exemptions)

- 1 Under paragraph 31A(1) of the *Road Transport (Dimensions and Mass) Act 1990* (the Act), I exempt a B-Double, a vehicle up to but not exceeding 4.6 metres in height and a bus with an overall length of greater than 12.5 metres but not exceeding 14.5 metres in length, that comply with and are operated in accordance with the conditions set out in the schedule attached to this exemption notice, from the requirements of sections 9 and 24 of the Act.
- 2 Under subsection 31A(2) of the Act, I exempt a person who holds a current driving licence authorising her or him to drive a B-Double, a vehicle not exceeding 4.6 metres in height, or a bus with an overall length of greater than 12.5 metres but not exceeding 14.5 metres in length from compliance with subsection 37(2) of the Act, in so far as that subsection relates to a B-Double to which this exemption notice, or a permit issued under subsection 27(1) of the Act that is in force, applies.
- 3 In this exemption notice:
 - ‘*dangerous goods*’ means any substance or article prescribed as a dangerous good under the *Dangerous Goods Act 1984* or the *Road Transport Reform (Dangerous Goods) Act 1995* of the Commonwealth.
 - ‘*heavy vehicle*’ means a motor vehicle or trailer with a GVM of more than 4.5 tonnes.
 - ‘*standards for registration*’ mean the standards specified by the Registration Authority, or the registration authority of a State or another Territory, for vehicle registrations.
 - ‘*bus*’ means a motor vehicle built mainly to carry passengers that seats over nine (9) people (including the driver).
 - ‘*controlled access bus*’ means a bus, except an articulated bus, over 12.5 metres but no more than 14.5 metres in length.

- 4 In this exemption notice a diagram that is called an essential diagram is part of the exemption notice. Any other diagram or any note is illustrative only. All other relevant legislation related to the operation of vehicles to which this notice is applicable must be adhered to.
- 5 This exemption notice commences on the date of notification and is to remain in force until it is repealed.

Bill Wood MLA
Minister for Urban Services

25 May 2004

Australian Capital Territory
Road Transport
(Dimensions and Mass)
Act 1990

62.5 TONNE B-Double,
4.6 METRE HIGH VEHICLE and
14.5 METRE LONG BUS

EXEMPTION NOTICE



Australian Capital Territory Government

Purpose of this booklet:

The purpose of this book is to provide heavy vehicle operators with information related to where in the ACT they can drive B-Doubles of up to 62.5 tonnes gross combination mass, vehicles of up to 4.6 metres in height and buses with an overall length of greater than 12.5 metres but which are no longer than 14.5 metres in length. The book takes the form of an exemption notice.

The information in the booklet is applicable to the following vehicles:

- (a) B-Doubles with a gross mass limit not exceeding 62.5 tonnes gross combination mass with a maximum height of 4.6 metres, width of 2.5 metres and length of 25 metres.*
- (b) All vehicles of up to 4.6 metres in height, operating at normal mass and length limits to or under a relevant notice or permit.*
- (c) Buses with an overall length of greater than 12.5 metres but which are no longer than 14.5 metres.*

Subject to meeting the conditions listed in this booklet, these vehicles may travel in the Australian Capital Territory on the roads which are listed in the booklet and shown on the accompanying map.

It is a requirement that this booklet is carried in a vehicle to which the notice applies.

I hope that the booklet will be of assistance to both the drivers and operators of heavy vehicles.

SHOULD YOU NEED ANY ASSISTANCE, PLEASE CONTACT A.C.T VEHICLE INSPECTION AND TECHNICAL UNIT ON (02) 6207 6565

Emergency contact details are provided on the back page of this booklet.

Bill Wood, Minister for Urban Services

SCHEDULE TO THE 62.5 TONNE B-DOUBLE, 4.6 METRE HIGH VEHICLE AND 14.5 METRE LONG BUS EXEMPTION NOTICE

The conditions, which are specified in this schedule, relate to the following vehicles operating in the Australian Capital Territory

- (a) *B-Doubles with a gross mass limit not exceeding 62.5 tonnes gross combination mass with a maximum height of 4.6 metres, width of 2.5 metres and length of 25 metres.*
- (b) *All vehicles of up to 4.6 metres in height, operating at normal mass and length limits to or under a relevant notice or permit.*
- (c) *Buses with an overall length of greater than 12.5 metres but which are no longer than 14.5 metres.*

Subject to meeting the conditions listed in this booklet, these vehicles may travel in the Australian Capital Territory on the roads which are listed in the booklet and shown on the accompanying map.

Preliminary Information

PART 1 - TRAVEL REQUIREMENTS

PART 2 - OPERATING CONDITIONS AND RESTRICTIONS

2.1 General

2.2 Braking Requirements

2.3 Requirements Related to Tyre Pressure

2.4 Distance Between Vehicles

2.5 Minimising Damage when Travelling

PART 3 - MASS AND DIMENSION LIMITS

3.1 Maximum Limits for Axles And Axle Groups

3.2 Maximum Gross Mass Limits

3.3 Maximum Dimension Limits

3.4 Mass Limits Relating to Axle Spacing

3.5 Spacing Rules

3.6 Measurement of Distances for Table 1

PART 4 - WARNING SIGNS FOR VEHICLES

4.1 B-Double Warning Signs

4.2 Warning Signs Not to be Used in Other Cases

4.3 Specifications for Warning Signs

PART 5 - B-DOUBLE STANDARDS AND SPECIFICATIONS

5.1 Compliance with Standards

5.2 Power of B-Double Prime Mover

5.3 Speed Limiting

5.4 Tracking

5.5 Turning Capability

5.6 Spray Suppression Devices

5.7 Braking Requirements for a B-Double

5.7.1 Braking requirements - general

5.7.2 Braking system design for a prime mover

5.7.3 Braking system design for a trailer

5.7.4 Air brakes - requirements for a prime mover

5.7.5 Air brakes - least favoured chamber

5.7.6 Recovery of air pressure for brakes

5.7.7 Air supply for brakes

5.7.8 Brake line couplings

5.7.9 Simultaneous parking brake application

5.7.10 Capacity of air reservoirs

5.8 Coupling Requirements for B-Doubles

5.8.1 Coupling requirements - general

5.8.2 Fifth wheel couplings

5.8.3 Selection of fifth wheel couplings

5.8.4 Determining the D-value of a fifth wheel coupling

5.8.5 Mounting of fifth wheel couplings on a B-Double

5.8.6 Branding of fifth wheel couplings

5.8.7 Selection of kingpins for a B-Double

5.8.8 Testing of kingpins

5.8.9 Attachment of kingpins

5.8.10 Branding of kingpins

PART 6 - APPROVED ROUTES AND TRAVEL CONDITIONS

6.1 Approved Routes and Travel Conditions

PART 7 – NOTE RELATED TO ROAD TRAINS

Refer to the Road Transport (Dimensions and Mass) Act 1990 - Section 37(2)

ATTACHMENT

Routes Approved for 62.5 Tonne B-Doubles, 4.6 Metre High Vehicles and 14.5 Metre Long Buses in the Australian Capital Territory

SCHEDULE TO THE 62.5 TONNE B-DOUBLE, 4.6 METRE HIGH VEHICLE AND 14.5 METRE LONG BUS EXEMPTION NOTICE

Conditions Applying to the Operation of B-Doubles with a Gross Mass Limit not exceeding 62.5 tonnes Gross Combination Mass, Vehicles not exceeding 4.6 Metres in Height and Controlled Access Buses in the Australian Capital Territory

PART 1-TRAVEL REQUIREMENTS

- 1.1.1 Vehicles of the dimensions and mass limits to which this exemption notice is applicable may operate only on approved routes and must observe any condition that applies to an approved route.

Notes: (a)	It is the responsibility of operators seeking approval of new routes to contact ACT Road User Services and follow the requirements specified in route assessment guidelines.
(b)	Operators may apply to ACT Road User Services for a specific permit for travel on any road other than those specified in Part 6.

- 1.1.2 Deviation from approved routes is not permitted except in emergencies. Emergency route deviations may only be made at the direction of an authorised officer or a member of the Police Service.

PART 2 - OPERATING CONDITIONS AND RESTRICTIONS

2.1 General

- 2.1.1 A copy of this exemption notice must be carried in the driving compartment whenever the vehicle is operating as part of a B-Double, a controlled access bus or is another vehicle to which this notice applies. This must be produced when requested by a police officer or by an authorised officer.
- 2.1.2 All requirements and conditions of this exemption notice are to be observed when a vehicle is operating as part of a B-Double, a vehicle not exceeding 4.6 metres in height or a controlled access bus.
- 2.1.3 The rearmost vehicle of a B-Double, must clearly display a warning sign at its rear in accordance with the requirements of Part 4 of this exemption notice.
- 2.1.4 Except as provided by this exemption notice, a vehicle operating as part of a B-Double, a vehicle more than 4.3 metres but not exceeding 4.6 metres in height or a controlled access bus must comply with the statutory requirements of the Act.
- 2.1.5 The prime mover and semi-trailers of a B-Double, a vehicle not exceeding 4.6 metres in height or a controlled access bus must be constructed to comply with the appropriate standards for registration, or the Australian Design Rules, unless otherwise stated.

- 2.1.6 All vehicles used in a B-Double, a vehicle not exceeding 4.6 metres in height or a controlled access bus must be registered in a State or Territory of the Commonwealth or under the Federal Interstate Registration Scheme.
- 2.1.7 The driver of a B-Double must hold, and be able to produce if requested, a driving licence authorising her or him to drive a B-Double or a controlled access bus.
- 2.1.8 The load limits set by this exemption notice must not be exceeded.
- 2.1.9 Despite clause 5.3, a person must not drive a vehicle to which this notice applies in excess of any speed limit set by law.
- 2.1.10 The owner, driver or person in charge of the vehicle must comply with any directions given by authorised officers, appropriately authorised persons acting in an official capacity on behalf of any other authorities concerned, or by any officer of the Australian Federal police (AFP).

These directions would relate to any reduction in speed, adjustment of the vehicle and load, the particular portion of the road and or structure on the route over which the vehicle is permitted to travel, or as to any other matter considered necessary for safe passage of vehicles to which this notice applies.

- 2.1.11 A vehicle, to which this notice applies, entering or exiting any site, must do so in a forward direction wherever possible and extreme care must be exercised when reversing.
- 2.1.12 A vehicle to which this notice applies must not be loaded or unloaded on a public street.

2.2 Braking Requirements

All vehicles to which this notice applies should refrain from braking, where possible, on the following bridges in the ACT. Additionally, a speed limit of 10 kilometres per hour is recommended for vehicles to which this notice applies on the following bridges:

- *Bridge on Yass Road over the Molonglo River;*
- *Bridge on Monaro Highway over Woden Creek.*
- *Bridge on Canberra Avenue southbound over Canberra Avenue ;*
- *Bridge on Canberra Avenue northbound over Canberra Avenue;*
- *Streeton Drive southbound over Weston Creek;*
- *Streeton Drive northbound over Weston Creek;*
- *Tuggeranong Parkway over Public Use Reserve, Waramanga;*
- *Drakeford Drive southbound over drain;*
- *Drakeford Drive northbound over drain.*

Please refer to the accompanying map for details.

2.3 Requirements Related to Tyre Pressure

All vehicles to which this notice applies must comply with the requirements of the *ACT Road Transport (Dimensions and Mass) Act 1990* as this relates to maximum allowable tyre pressure. This provision is as follows: The pressure in a pneumatic tyre of a vehicle shall not exceed:

- (a) In the case of radial ply tyre : 825 kilopascals ; or
- (b) In any other case: 700 kilopascals.

2.4 Distance between Vehicles

A vehicle to which this notice applies must travel at least 200 metres behind a heavy vehicle, or a trailer or caravan attached to a vehicle, except when:

- (a) it is overtaking or being overtaken by another vehicle;
- (b) the vehicle ahead is stopping or stationary;
- (c) there is a separate lane for overtaking; or
- (d) it is travelling in an urban area, or where the speed limit is set at 60 km/h or less, where it is impractical to maintain a distance of 200 metres.

2.5 Minimising Damage when Travelling

- 2.5.1 The owner, driver or person in charge of the vehicle, shall take care to avoid damage to sign boards, guard posts and other roadside fixtures. No board, post or other fixture shall be removed unless it is essential to do so and in any case not until prior approval has been obtained from the relevant authority concerned.

Where it is found necessary to remove any board, post or other fixture, it should be replaced immediately in the same position and in the same condition as at the time of removal. All costs incurred in remedying any default or neglect in this regard shall be recoverable from the operator by the Road Transport Authority on behalf of ACT Infrastructure Management, as provided for in the ACT.

- 2.5.2 In all cases, but particularly when moving high and/or wide loads, it is the responsibility of owner, driver or person in charge of the vehicle to ensure there is no damage to trees or shrubs. It is an offence under both the *Nature Conservation Act 1980* and the *Trespass on Territory Land Act 1932* to change or destroy trees or shrubs and any person offending may be subject to prosecution.

PART 3 - MASS AND DIMENSION LIMITS

3.1 Maximum Limits For Axles And Axle Groups

3.1.1 The maximum axle mass limits for a B- Double or other vehicle to which this notice applies must be the lowest of:

- (a) Single steering axle - 6.0 tonnes gross
- Twinsteer axle group; non load sharing - 10 tonnes gross
- Twinsteer axle group; load sharing - 11 tonnes gross
- Single axle consisting of 4 tyres - 9.0 tonnes gross
- Tandem axle consisting of 6 tyres with air suspension - 14 tonnes gross
- Tandem axle consisting of 6 tyres without air suspension - 13 tonnes gross
- Tandem axle consisting of 8 tyres - 16.5 tonnes gross
- Tri-axle group consisting of 12 tyres - 20.0 tonnes gross
- Tri-axle group consisting of 6 tyres with section widths of at least 375 millimetres - 20.0 tonnes gross
- (b) the manufacturer's mass ratings; or
- (c) the sum of the mass limits for the tyres fitted to the axles and axle groups.

3.2 Maximum Gross Mass Limits

3.2.1 The maximum gross mass limit for a B-Double must be the lowest of:

- (a) the sum of the applicable axle and axle group mass limits in clause 3.1.1 (a);
- (b) the sum of the manufacturers' mass limits (GVM) for the prime mover and semi-trailer;
- (c) the gross combination mass limit (GCM) specified by the prime mover manufacturer; or
- (d) 62.5 tonnes.

3.2.2 The maximum gross mass limit for a vehicle not exceeding 4.6 metres in height must be the lowest of:

- (a) the sum of the applicable axle and axle group mass limits in clause 3.1.1 (a);
- (b) the sum of the manufacturers' mass limits (GVM) of each vehicle in a combination;
- (c) the gross combination mass limit (GCM) specified by the prime mover manufacturer or towing vehicle; or
- (d) statutory limits for the vehicle.

3.2.3 The maximum gross mass limit for a controlled access bus is the lesser of the statutory axle mass limits and the capacity of the bus.

3.3 Maximum Dimension Limits

3.3.1 Prime movers and semi-trailers must comply with Third Edition Australian Design Rule 43.

3.3.2 A B-Double to which this notice applies must not be more than 25.0 metres long.

3.3.3 A vehicle to which this notice applies must not be more than 4.6 metres high.

3.3.4 A controlled access bus must not have an overall length of greater than 14.5 metres. Other dimensions must not exceed the requirements of the Third Edition Australian Design Rule 43.

3.3.5 Despite the provisions of Clause 3.3.4 the rear overhang of a controlled access bus must not exceed 70% of the distance between the centre of the foremost axle and the foremost extremity of the rear overhang, or 4.9 metres, whichever is the shorter length.

3.4 Mass Limits Relating To Axle Spacing

3.4.1 For any B-Double, the mass limits in Table 1 must not be exceeded in relation to the distances set out in that Table that apply to the B-Double or any vehicle forming part of it.

3.4.2 For any B-Double, the mass limits in section (C) of Table 1 apply to the sum of the masses of each axle group or single axle in the distance referred to in that Table, including the axles between which the distance is measured.

3.4.3 For all vehicles of up to 4.6 metres in height other than B-Doubles, normal mass limits for these vehicles apply or conditions specified under a relevant Notice or Permit, are applicable.

3.5 Spacing Rules

3.5.1 A B-Double with two tri-axle groups must conform to the formulae:

$$x - y \leq 1 \text{ and } y - x \leq 1.3$$

where:

x is the distance in metres between the centres of the closest axles of the second and third axle groups; and

y is the distance in metres between the centres of the closest axles of the third and fourth axle groups,

treating the steer axles as the first axle group and assigning to the next rearmost axle group the description 'second axle group', and to each successive axle group a higher ordinal number.

Figure 1

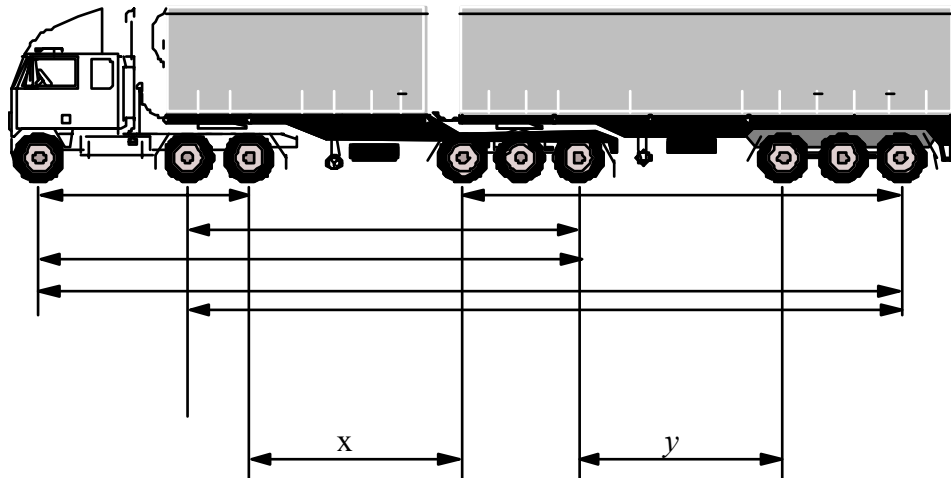

- 3.5.2 For B-Doubles other than those referred to in clause 3.5.1, the distance between the centres of tandem axle groups must not be less than 6 metres and the distance between the centres of the tandem and tri-axle groups must not be less than 7 metres.
- 3.5.3 The distance between the axles closest to each other in any adjacent multi-axle groups in a B-Double must not differ from the distance between the axles closest to each other in any other adjacent multi-axle groups by more than one metre.
- 3.5.4 The total mass of a vehicle or combination, and any load, must not exceed 15 tonnes if the distance between any two axles that are not part of the same axle group is less than 2.5 metres.

3.6 Measurement of distances for Table 1

3.6.1 Each distance in Table 1 refers to:

- (a) the distance from the centre of any single axle to the centre of any other single axle;
- (b) the distance from the centre of any single axle to the centre of the furthest axle in any axle group; or
- (c) the greatest distance between the centres of axles in any two axle groups.

Table 1 - Mass limits relating to axle spacings - B-Doubles

(A)

<ul style="list-style-type: none"> For any B-Double, the loaded mass of which can lawfully exceed 42.5 tonnes where the distance between the extreme axles is less than 21 metres, the mass limit must not exceed that calculated in accordance with the formula opposite. 	<p style="text-align: center;">$M = 1.5L + 29.5$</p> <p>where:</p> <ul style="list-style-type: none"> M is the mass limit in tonnes; and L is the distance in metres.
---	---

(B)

<ul style="list-style-type: none"> For any B-Double, the loaded mass of which can lawfully exceed 42.5 tonnes where the distance between the extreme axles is not less than 21 metres, the mass limit must not exceed that specified opposite. 	<p style="text-align: center;">62.5 tonnes</p>
---	---

(C)

<ul style="list-style-type: none"> For all B-Doubles, the axle loads of the axles in any two or more adjacent axle groups (or of any single axle and the axles in one or more adjacent axle groups) must not exceed that calculated in accordance with the formulae opposite. 	<p style="text-align: center;">a) $M = 3L + 12.5$</p> <p>where:</p> <ul style="list-style-type: none"> M is the mass limit in tonnes; and L is a distance less than or equal to 11.33 metres. <p style="text-align: center;">b) $M = 1.5L + 29.5$</p> <p>where:</p> <ul style="list-style-type: none"> M is the mass limit in tonnes; and L is a distance greater than 11.33 metres.
--	--

PART 4 - WARNING SIGNS

4.1 Warning signs

- 4.1.1 A vehicle or combination to which this notice applies that is more than 22 metres long must have fitted horizontally to the rearmost part of it a warning sign in accordance with the requirements of this Part.
- 4.1.2 The sign must show the words "LONG VEHICLE" in black upper case letters at least 180 millimetres high in typeface Series B (N), complying with *Australian Standard AS1744, Forms of Letters and Numerals for Road Signs*.
- 4.1.3 If the sign is in two pieces, the word "LONG" must appear on one piece and the word "VEHICLE" on the other.
- 4.1.4 A B-Double warning sign, or piece of a B-Double warning sign, must not be displayed on:
- (a) a vehicle that does not form part of a B-Double; or
 - (b) a B-Double that is not more than 22 metres long.

4.2 Warning signs not to be used in other cases

- 4.2.1 A "LONG VEHICLE" warning sign must not be used on a vehicle or combination except in accordance with this Part.

4.3 Specifications for warning signs

- 4.3.1 A warning sign must be:
- (a) durable; and
 - (b) manufactured in one or 2 pieces from sheet steel 0.8 millimetres thick or an alternative material of at least equivalent stiffness, unless it is designed to be fixed to the vehicle body using an adhesive.
- 4.3.2 A warning sign must be at least 1.02 metres long by 250 millimetres high.
- 4.3.3 A warning sign must be coated with yellow retro-reflective material (Class 1 or Class 2) which meets *Australian Standard AS1906 Retro-reflective Materials and Devices for Road Traffic Control Purposes*.
- 4.3.4 A warning sign must have a black border.
- 4.3.5 A warning sign must show the sign manufacturer's name or logo, and the brand and class of retro-reflective material used, in block letters not more than 10 millimetres high.
- 4.3.6 A warning sign must be mounted so that no part of it is:
- (a) more than 1.8 metres above the ground; or
 - (b) less than 500 millimetres above the ground

PART 5 - B-DOUBLE STANDARDS AND SPECIFICATIONS.

5.1 Compliance With Standards

- 5.1.1 A B-Double must comply with each applicable Design Rule (ADR).
- 5.1.2 A vehicle must comply with each standard specified in this exemption notice, unless the exemption notice is inconsistent with an ADR that applies to it.

5.2 Power Of B-Double Prime Mover

- 5.2.1 The minimum power required of a hauling unit must be 300 kilowatts.
- 5.2.2 An exception to the above requirement may be given if it can be demonstrated to the Registrar that the vehicle is capable of starting movement on a 12% gradient, and is capable of maintaining a constant speed of 70 km/h on a 1% gradient when operating at the nominated Gross Combination Mass.
- 5.2.3 If the manufacturer of a motor vehicle forming part of a B-Double has not determined the GCM of the vehicle, the total mass of the combination and any load must not exceed the number of kilograms worked out using the following formula:

$$\text{Mass in kilograms} = \frac{K \times M \times R \times T}{16}$$

where:

K means:

- (a) **0.055** if a single drive axle is fitted to the motor vehicle;
- (b) **0.053** if a single drive tandem axle is fitted to the motor vehicle; or
- (c) **0.051** if a dual drive tandem axle group is fitted to the motor vehicle;

M means the number of tyre revolutions per kilometre as specified by the tyre manufacturer for the tyres fitted to the driving axle or axles;

R means the overall gear reduction between engine and wheels; and

T means the maximum engine net torque in Newton-metres.

5.3 Speed Limiting

- 5.3.1 A B-Double must comply with the speed limiting requirements of Third Edition Australian Design Rule 65.
- 5.3.2 A B-Double must be speed limited so that it has a maximum road speed capability of 100 km/h.

5.4 Tracking

- 5.4.1 When travelling in a straight line on a level, smooth surface, all units in a B-Double must track in the path of the prime mover without shifting or swerving more than 100 mm either side of the path of the prime mover.

5.5 Turning Capability

- 5.5.1 A B-Double must be able to turn in a circle not over 25 metres in diameter, measured by the outer edge of the tyre track at ground level.
- 5.5.2 The vehicle must be able to comply with subclause 5.5.1 whether it turns to the left or to the right.

5.6 Spray suppression devices

- 5.6.1 Spray suppression devices must be fitted to all axle groups and single axles of a B- Double combination.
- 5.6.2 The spray suppression devices must comply with the requirements of British Standard AU 200-1984, Parts 1 and 2.

5.7 Braking Requirements for a B-Double

5.7.1 Braking Requirements – General:

- 5.7.1.1 The braking requirements in this Part apply in addition to the braking system requirements that apply to all heavy vehicles.

5.7.2 Braking system design for a prime mover:

- 5.7.2.1 A prime mover used in a B-Double must meet the requirements of either Second Edition ADR 35A or Third Edition ADR 35.

- 5.7.2.2 A prime mover used in a B-Double must also have an anti-lock brake system that complies with ADR 64, if the prime mover:

- (a) was manufactured on or after 1 January 1990;
- (b) was first used in a B-Double on or after 1 January 1994; or
- (c) is used in a B-Double combination that includes a road tank vehicle that carries dangerous goods.

5.7.3 Braking system design for a trailer

- 5.7.3.1 A trailer that is used in a B-Double, and is not otherwise required to comply with an ADR relating to braking, must comply with the requirements specified in Second or Third Edition ADR 38 for the performance of:

- (a) the service brake system;
- (b) the emergency brake system; and
- (c) the parking brake system.

- 5.7.3.2 A semi-trailer, regardless of its date of manufacture, must have an anti-lock braking system that meets the requirements of ADR 38, if:

- (a) it is being used in a B-Double that includes a road tank vehicle, whether or not the semi-trailer is itself a road tank vehicle; and
- (b) the road tank vehicle carries dangerous goods.

5.7.4. Air brakes - requirements for a prime mover

- 5.7.4.1 If a B-Double is fitted with brakes that operate using compressed air, the braking system of the prime mover must meet the requirements of this Part when:
- (a) the pressure is measured in an 800 millilitre vessel connected by a 2 metre pipe with a bore of approximately 13 millimetres to the coupling head of the braking system; and
 - (b) the initial air pressure is not less than:
 - (i) the arithmetic average of the maximum and minimum pressures in the operating pressure range specified by the manufacturer of the vehicle; or
 - (ii) if there is no manufacturer's specification - 650 kilopascals.
- 5.7.4.2 The pressure must reach at least 420 kilopascals within 400 milliseconds after the rapid and complete application of the foot-operated control of the braking system.
- 5.7.4.3 After the brakes have been fully applied, the pressure must fall within half a second of the release of the foot-operated control to 35 kilopascals.
- 5.7.5 Air brakes - least favoured chamber**
- 5.7.5.1 The pressure in the least favoured chamber of the braking system of a B-Double whose brakes operate using compressed air must meet the requirements of this sub- clause when the initial air pressure is not less than:
- (a) the arithmetic average of the maximum and minimum pressures in the operating pressure range specified by the manufacturer of the vehicle; or
 - (b) if there is no manufacturer's specification - 650 kilopascals.
- 5.7.5.2 The pressure must reach at least 420 kilopascals within 1.0 second of the rapid and complete application of the foot-operated control.
- 5.7.5.3 After the brakes have been fully applied, the pressure must fall to 35 kilopascals or the pressure at which the friction surfaces cease to contact each other within 1.0 second of the release of the foot-operated brake control on a B-Double.

Note: The "least favoured chamber" means the brake chamber with the longest line to the treadle valve in the prime mover.

5.7.6 **Recovery of air pressure for brakes**

5.7.6.1 The air pressure in each air brake reservoir in a B-Double must recover to at least 420 kilopascals within one minute after 3 full brake applications have been made within a 10 second period if, before the 3 brake applications have been made:

- (a) the engine is running at maximum speed; and
- (b) the governor cut-in pressure is no higher than:
 - (i) the pressure recommended by the manufacturer; or
 - (ii) if there is no recommendation by the manufacturer – 550 kilopascals; and
- (c) the initial air pressure in the storage tanks of the vehicles is not less than:
 - (i) the arithmetic average of the maximum and minimum pressures in the operating pressure specified by the manufacturer of the vehicle; or
 - (ii) if there is no manufacturer's specification - 650 kilopascals.

5.7.7 **Air supply for brakes**

5.7.7.1 A B-Double that uses compressed air to operate accessories must have:

- (a) sufficient air compressor capacity and air receiver volume to ensure that the operation of the accessories does not adversely affect brake performance; and
- (b) a compressed air system built to ensure that the brake system is preferentially charged.

5.7.8 **Brake line couplings**

5.7.8.1 Brake line couplings on the same part of a vehicle in a B-Double must not be interchangeable.

5.7.8.2 The couplings must be polarised in accordance with *Australian Standard AS D8-1971, Hose couplings for use with vacuum and air-pressure braking system on prime movers, trailers and semi-trailers* if the hoses used with the brake couplings are used for the same purpose as the hoses described in the Australian Standard.

5.7.9 **Simultaneous parking brake application**

5.7.9.1 If the parking brake of a motor vehicle in a B-Double is applied, the parking brakes of any attached trailer must also be applied automatically.

5.7.10 **Capacity of air reservoirs**

5.7.10.1 The capacity of the air storage tanks of a motor vehicle used in a B-Double must be at least 12 times the volume of all the brake activation chambers on the vehicle.

5.7.10.2 The capacity of the air storage tanks of a trailer used in a B-Double must be at least 8 times the volume of all the brake activation chambers on the trailer.

5.8 Coupling requirements for B-Doubles

5.8.1 Coupling requirements - general

5.8.1.1 The coupling requirements for B-Doubles listed in this section apply in addition to coupling requirements that apply to all heavy vehicles.

5.8.1.2 These requirements do not apply to a vehicle, coupling or part of a coupling that is used in a B-Double that has a length of 19 metres or less.

5.8.2 Fifth wheel couplings

5.8.2.1 A fifth wheel coupling used to connect a towing vehicle to a semi-trailer used in a B- Double must not be built with a pivot that allows a semi-trailer to roll relative to the towing vehicle.

5.8.2.2 The above does not apply to a fifth wheel coupling if:

- (a) the semi-trailer design requires torsional stresses to be minimised;
- (b) the roll axis of the fifth wheel coupling is above the surface of the coupler plate; and
- (c) the degree of rotation allowed around the roll axis of the fifth wheel coupling is restricted to prevent roll instability.

5.8.2.3 A turntable used in a vehicle that forms part of a B-Double must be marked with:

- (a) the name or trademark of the manufacturer; and
- (b) the D-value rating, of the turntable.

5.8.3 Selection of fifth wheel couplings

5.8.3.1 A fifth wheel coupling used in a B-Double must have a D-value of at least 107 kilonewtons (11.0 tonnes) that accords with *Australian Standard AS 1773–1990, Articulated Vehicles - Fifth wheel assemblies*.

5.8.3.2 A fifth wheel coupling used in a B-Double that is built for a 50 millimetre or 90 millimetre kingpin must:

- (a) meet the dimensional requirements in *Australian Standard AS 1773–1990, Articulated Vehicles - Fifth wheel assemblies*; and
- (b) not be worn more than is recommended by that Australian Standard.

5.8.3.3 A fifth wheel coupling used in a B-Double that is built for a 75 millimetre kingpin must:

- (a) be compatible with the kingpin described in clause 5.8.7.3; and
- (b) not be worn more than is specified in clauses 5.8.4.1(a) and (b).

5.8.4 Determining the D-value of a fifth wheel coupling

5.8.4.1 When testing a fifth wheel coupling built for a 75 millimetre kingpin used in a B-Double to determine whether its D-value meets the requirements of clause 5.8.3:

- (a) the closed jaw diameter must not wear more than 2.6 millimetres; and
- (b) the jaw thickness must not wear more than 3 millimetres.

5.8.5 Mounting of fifth wheel couplings on a B-Double

5.8.5.1 A fifth wheel coupling must be mounted on a prime mover or a semi-trailer used in a B-Double in accordance with the requirements of *Australian Standard AS 1771–1987, Installation of fifth wheel and turntable assemblies*.

5.8.6 Branding of fifth wheel couplings

5.8.6.1 A fifth wheel coupling on a vehicle manufactured on or after 1 July 1991 forming part of a B-Double must be clearly and permanently marked in accordance with *Australian Standard AS 1773–1990, Articulated Vehicles - Fifth wheel assemblies*, with:

- (a) the name or trademark of its manufacturer;
- (b) its D-value rating; and
- (c) its nominal size.

5.8.7 Selection of kingpins for a B-Double

5.8.7.1 A kingpin used in a B-Double must:

- (a) be a 50 millimetre, 75 millimetre or 90 millimetre kingpin; and
- (b) have a D-value of at least 162 kilonewtons (16.5 tonnes) that accords with *Australian Standard AS 2175–1990, Articulated Vehicles - Kingpins*.

5.8.7.2 A 50 millimetre or 90 millimetre kingpin used in a B-Double must:

- (a) be built to meet the dimensional requirements in *Australian Standard AS 2175–1990 Articulated Vehicles - Kingpins*; and
- (b) not be worn more than is recommended by that Australian Standard

5.8.7.3 A 75 millimetre kingpin used in a B-Double must:

- (a) be built to meet the dimensions specified in the essential diagram below; and
- (b) not be worn away more than is specified in clauses 5.8.8.1 (a), (b) or (c).

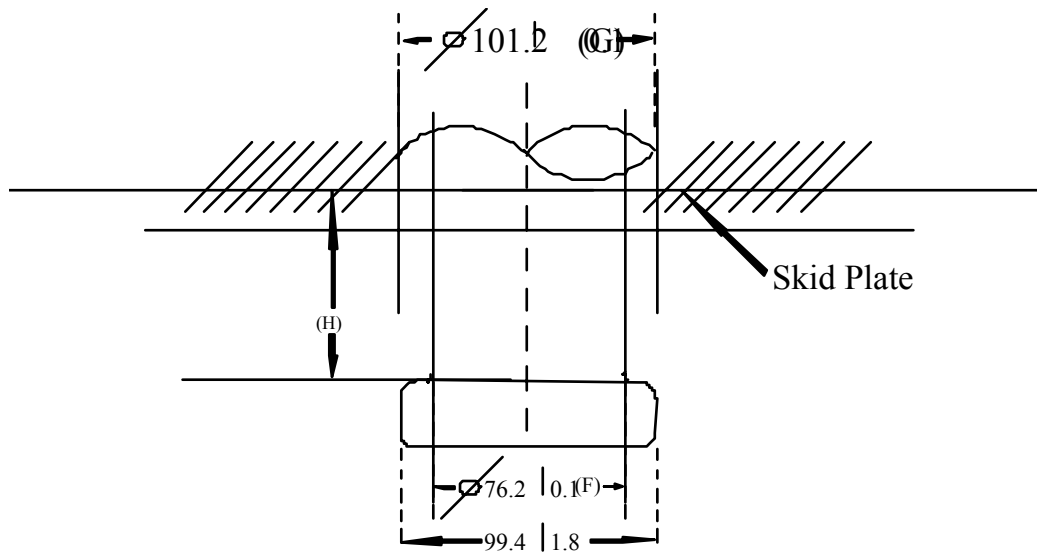

ALL DIMENSIONS IN MILLIMETERS

5.8.8 Testing of kingpins

5.8.8.1 When testing a 75 millimetre kingpin described in the essential diagram above to determine whether its D-value meets those requirements:

- (a) diameter F must not be worn more than 3 millimetres;
- (b) diameter G must not be worn more than 2 millimetres; and
- (c) height H must not be worn more than 2.3 millimetres.

5.8.9 Attachment of kingpins

5.8.9.1 A kingpin on a trailer used in a B-Double must be attached in accordance with:

- (a) the manufacturer's recommendations and instructions; or
- (b) the guidelines detailed in *Australian Standard AS 2175-1990, Articulated vehicles - Kingpins*.

5.8.10 Branding of kingpins

5.8.10.1 A kingpin used in a trailer manufactured on or after 1 July 1991 that forms part of a B-Double must be clearly and permanently marked on the lower circular face of the kingpin in accordance with *Australian Standard AS 2175-1990, Articulated Vehicles - Kingpins* with:

- (a) the name or trademark of its manufacturer;
- (b) its D-value; and
- (c) its nominal size.

PART 6 - APPROVED ROUTES AND TRAVEL CONDITIONS

6.1 Approved Routes and Travel Conditions

- 6.1.1 A B-Double, controlled access bus or other vehicle to which this notice applies may operate on the approved routes listed in the Attachment.
- 6.1.2 The travel restrictions and conditions which apply to an approved route must be observed.
- 6.1.3 Deviation from approved routes is not permitted except in emergencies. Emergency route deviations may be made only at the direction of an authorised officer or a police officer.

1. Routes currently approved are listed in the Attachment. Additional routes may be approved in future. Operators may obtain details of these from the Vehicle Inspection and Technical Unit of the Department of Urban Services ACT.
2. It is the responsibility of operators seeking approval of new routes to initiate contact with the Vehicle Inspection and Technical Unit of Road User Services ACT.
3. Operators must apply to the Vehicle Inspection and Technical Unit of the Department of Urban Services for a permit to travel on any route other than an approved route.
4. Approval of a road for use by oversize vehicle does **not** necessarily mean that unrestricted access to any adjacent site is permitted. Vehicle Inspection and Technical Unit of Road User Services can provide advice on site access but it remains the responsibility of the operator and the driver to ensure that the site is accessible without a breach of these conditions or any other applicable law before attempting to do so.
5. This notice **only** permits operation on approved routes in the ACT. It does **not** authorise operation across the NSW border. Operators wishing to do so must comply with the NSW requirements.

PART 7 – NOTE RELATED TO ROAD TRAINS IN THE ACT

Under no circumstances must road trains operate on roads within the ACT. Refer to the Road Transport (Dimensions and Mass) Act 1990 - Section 37(2).

The following is to go inside the back cover and on the map.....

Emergency and other contact telephone numbers:

Australian Federal Police:

000 – *Life Threatening Emergency*
11444 – *Police Attendance*
(02) 6256 7777 – *General Enquiries*

ACT Vehicle Inspection and Technical Unit:

(02) 6207 6565 (*Business Hours*)
(02) 6207 5300 (*After Hours*)
(02) 6207 6561 (*Facsimile*)

ROUTES APPROVED FOR B-DOUBLES; VEHICLES UP TO 4.6 METRES HIGH AND 14.5 METRE LONG BUSES IN THE AUSTRALIAN CAPITAL TERRITORY

Unless otherwise indicated, all routes listed in this attachment are approved for use by

- (a) *B-Doubles with a gross mass limit not exceeding 62.5 tonnes gross combination mass with a maximum height of 4.6 metres, width of 2.5 metres and length of 25 metres.*
- (b) *All vehicles of up to 4.6 metres in height, operating at normal mass and length limits to or under a relevant notice or permit.*
- (c) *Buses with an overall length of greater than 12.5 metres but which are no longer than 14.5 metres.*

NATIONAL HIGHWAYS & MAIN ROADS INTO ACT	FROM	TO	RESTRICTIONS/CONDITIONS (if applicable)
Barton Highway	Entire length (NSW border)	(Northbourne Ave)	
Canberra Avenue	NSW border	Hume Place	
Federal Highway	Entire length (NSW border)	(Northbourne Ave)	
Kings Highway	Entire length (NSW border)	(NSW border)	
Monaro Highway	Entire length (NSW border)	Dairy Road	
Sutton Road	Entire length (NSW border)	(Yass Rd)	
Yass Road	Entire length (NSW border)	Sutton Road	

ROUTES APPROVED FOR B-DOUBLES; VEHICLES UP TO 4.6 METRES HIGH AND 14.5 METRE LONG BUSES IN THE AUSTRALIAN CAPITAL TERRITORY

NATIONAL HIGHWAYS & MAIN ROADS INTO ACT	FROM	TO	RESTRICTIONS/CONDITIONS (if applicable)
Albany Street	Entire length (Collie St)	(Gladstone St)	
Anketell Street	Entire length (Athllon Dr)	(Athllon Dr)	Operation not permitted from 7.00am to 9.30 am and 4.30pm to 6.30pm on Monday to Thursday. Operation not permitted from 7.00am to 9.30am and from 4.30pm to 9.00pm on Fridays. Operation not permitted from 9.00am to midday on Saturdays. Refer to Restricted Access Route 3 for additional restrictions.
Anthony Rolfe Street	Entire length (Gundaroo Dr)	(end)	Operation not permitted from 7.00am to 9.30am and 4.30pm to 6.30pm on Monday to Thursday. Operation not permitted from 7.00am to 9.30am and 4.30pm and 9.00pm on Fridays. Operation not permitted from 9.00am to midday on Saturdays. Refer to Restricted Access Route 10 for additional restrictions.
Antill Street	Northbourne Avenue	Badham Street	Westbound one-way traffic only between Badham St and Challis St - refer to Restricted Access Route 2.
Arnott Place	Entire length (Sheppard St)	(end)	
Arnott Street	Entire length (Sheppard St)	(NSW border)	

ROUTES APPROVED FOR B-DOUBLES; VEHICLES UP TO 4.6 METRES HIGH AND 14.5 METRE LONG BUSES IN THE AUSTRALIAN CAPITAL TERRITORY

NATIONAL HIGHWAYS & MAIN ROADS INTO ACT	FROM	TO	RESTRICTIONS/CONDITIONS (if applicable)
Ashley Drive	Sternberg Crescent	Isabella Drive	Operation not permitted between Erindale Dr and Sternberg Cr from 7.30 am to 9.30 am and 4.30 pm to 7.00 pm, Monday to Friday. Refer to Restricted Access Route 6 for additional restrictions.
Athllon Drive	Entire length (Hindmarsh Dr)	(Isabella Dr)	
Badham Street	Cape Street	Antill Street	Refer to Restricted Access Route 2 for restrictions.
Baillieu Court	Entire length (Lysaght St)	(Lysaght St)	
Balcombe Street	Entire length (Sidney Nolan St)	(end)	
Ballumbir Street	Entire length (Cooyong St)	(Coranderrk St)	
Barrier Street	Entire length (Ipswich St)	(Newcastle St)	No right turn into Ipswich St Refer to Restricted Access Route 11 for additional details.
Belconnen Way	Kingsford-Smith Drive	Haydon Drive	
Benjamin Way	Joynton Smith Drive	Belconnen Way	
Bindubi Street	Entire length (Belconnen Way)	(William Hovell Dr)	
Bowman Street	Entire length (Redfern St)	(Redfern St)	
Box Hill Avenue	Balcombe Street	Tharwa Drive	
Brierly Street	Entire length (Hindmarsh Dr)	(Liardet St)	
Brindabella Road	Cotter Road	Mt Franklin Road (Picadilly Circus)	Forestry and livestock traffic only. No loaded B-Doubles between Uriarra Road and Cotter Road except with permit.
Brookes Street	Entire length (Lysaght St)	(Sandford St)	
Buckland Street	Entire Length (Grimwade Street)	(Brookes Street)	
Callan Street	Entire length (Vicars St)	(end)	
Canberra Avenue	Hume Place	State Circle	
Cape Street	Challis Street	Badham Street	Refer to Restricted Access Route 2 for restrictions.

ROUTES APPROVED FOR B-DOUBLES; VEHICLES UP TO 4.6 METRES HIGH AND 14.5 METRE LONG BUSES IN THE AUSTRALIAN CAPITAL TERRITORY

NATIONAL HIGHWAYS & MAIN ROADS INTO ACT	FROM	TO	RESTRICTIONS/CONDITIONS (if applicable)
Captain Cook Crescent	Franklin Street	Canberra Avenue	Northbound one-way traffic only Operation not permitted from 7.00am to 9.00am and 4.00pm to 6.30pm on Monday to Thursday. Operation not permitted from 7.00am to 9.00am and 4.00pm and 10.00pm on Fridays. Refer to Restricted Access Route 1.
Challis Street	Antill Street	Cape Street	Refer to Restricted Access Route 2 for restrictions.
Chan Street	Entire length (Lathlain St)	(Benjamin Way)	
Cheney Place	Entire length (Essington St)	(Crace Place)	
Cohen Street	Entire length (Lathlain St)	(Nettlefold St)	Operation not permitted from 7.00am to 9.30 am and 4.30pm to 6.30pm on Monday to Thursday. Operation not permitted from 7.00am to 9.30am and from 4.30pm to 9.00pm on Fridays. Operation not permitted from 9.00am to midday on Saturdays. Refer to Restricted Access Route 4 for additional restrictions.
College Street	Lathlain Street	Benjamin Way	
Collie Street	Entire length (Newcastle St)	(Wollongong St)	No right turn into Wollongong St.
Cooyong Street (1)	Lonsdale Street	(Ballumbir St)	Refer to Restricted Access Route 5 for additional restrictions.
Cooyong Street (2)	Northbourne Avenue	Lonsdale street	
Coppins Crossing Road, Belconnen	Entire length (William Hovell Drive)	(Uriarra Road)	Forestry and livestock traffic only.
Coranderrk Street	Ballumbir Street	Parkes Way	

ROUTES APPROVED FOR B-DOUBLES; VEHICLES UP TO 4.6 METRES HIGH AND 14.5 METRE LONG BUSES IN THE AUSTRALIAN CAPITAL TERRITORY

NATIONAL HIGHWAYS & MAIN ROADS INTO ACT	FROM	TO	RESTRICTIONS/CONDITIONS (if applicable)
Cotter Road	Streeton Drive	Brindabella Road	Forestry and livestock traffic only. No loaded B-Doubles between Eucumbene Drive and Brindabella Road except with permit.
Coulter Drive	Ginninderra Drive	Belconnen Way	
Cowlshaw Street	Athllon Drive	Scollay Street	
Cunningham Street	The Causeway	Wentworth Avenue	
Dacre Street	Entire Length (Hoskins Street)	End	
Dairy Road	Entire length (Newcastle St)	(Morshead Dr / Piallago Avenue intersection)	
Dalby Street	Entire length (Mildura St)	(Canberra Ave)	
Darling Street	Entire length (Lysaght St)	(Sandford St)	
Drake-Brockman Drive	Entire length (William Hovell Dr)	(Stockdill Dr)	
Drakeford Drive	Entire length (Tuggeranong Pkway)	(Tharwa Dr)	No turn into Johnson Dr.
Erindale Drive	Entire length (Yamba Dr)	(Soward Way)	
Ernest Cavanagh Street	Gozzard Street	Unnamed Street at eastern perimeter of Gungahlin Market Place.	One way east-west movement only past entrance to Woolworths loading bay. Operation not permitted from 7.00am to 9.30 am and 4.30pm to 6.30pm on Monday to Thursday. Operation not permitted from 7.00am to 9.30am and 4.30pm and 9.00pm on Fridays. Operation not permitted from 9.00am to midday on Saturdays. Refer to Restricted Access Route 10 for additional restrictions.
Essington Street	Entire length (Vicars St)	(Lysaght St)	
Eucumbene Drive	Entire length (Cotter Rd)	(Hindmarsh Dr)	Forestry and livestock traffic only.
Fairbairn Avenue	Morshead Drive	Piallago Avenue	
Flemington Road	Entire length (Lysaght St)	(Northbourne Ave)	

ROUTES APPROVED FOR B-DOUBLES; VEHICLES UP TO 4.6 METRES HIGH AND 14.5 METRE LONG BUSES IN THE AUSTRALIAN CAPITAL TERRITORY

NATIONAL HIGHWAYS & MAIN ROADS INTO ACT	FROM	TO	RESTRICTIONS/CONDITIONS (if applicable)
Flinders Way	Manuka Circle	Franklin Street	Southbound one-way traffic only. Operation not permitted from 7.00am to 9.00am and 4.00pm to 6.30pm on Monday to Thursday. Operation not permitted from 7.00am to 9.00am and 4.00pm and 10.00pm on Fridays. Refer to Restricted Access Route 1 for additional restrictions.
Franklin Street	Flinders Way	Captain Cook Crescent	Eastbound one-way traffic only. Operation not permitted from 7.00am to 9.00am and 4.00pm to 6.30pm on Monday to Thursday. Operation not permitted from 7.00am to 9.00am and 4.00pm and 10.00pm on Fridays. Refer to Restricted Access Route 1 for additional restrictions.
Geelong Street	Entire length (Canberra Ave)	(end)	
Ginninderra Drive (1)	Haydon Drive	Mouat Street	
(2)	William Slim Drive	Coulter Drive	
Girrahween Street	Lonsdale Street	Northbourne Avenue	Operation not permitted from 8.00am to 9.30am and 4.00pm to 6.30pm on , Monday to Friday and operation not permitted from 9.00am to midday on Saturdays.

ROUTES APPROVED FOR B-DOUBLES; VEHICLES UP TO 4.6 METRES HIGH AND 14.5 METRE LONG BUSES IN THE AUSTRALIAN CAPITAL TERRITORY

NATIONAL HIGHWAYS & MAIN ROADS INTO ACT	FROM	TO	RESTRICTIONS/CONDITIONS (if applicable)
Gladstone Street (Fyshwick)	Entire length (Newcastle St)	(Tennant St)	
Gladstone Street (Hall)	Wallaroo Road	Victoria Street	Eastbound one-way traffic only. Refer to Restricted Access Route 9 for additional restrictions
Gozzard Street	Ernest Cavanagh Street	Hibberson St	One way south to north movement only between Hibberson and Ernest Cavanagh Streets. Operation not permitted from 7.00am to 9.30 am and 4.30pm to 6.30pm on Monday to Thursday. Operation not permitted from 7.00am to 9.30am and 4.30pm and 9.00pm on Fridays. Operation not permitted from 9.00am to midday on Saturdays. Refer to Restricted Access Route 10 for additional restrictions.
Grimwade Street	Entire length (Lysaght St)	(Sandford St)	
Gundaroo Drive	Barton Highway	Anthony Rolfe Street	
Gunghalin Drive	Gundaroo Drive	Barton Highway	
Haydon Drive	Entire length (Ginninderra Dr)	(Belconnen Way)	
Heffernan Street	Entire length (Grimwade St)	(Darling St)	
Hibberson Street	Gozzard St	Unnamed street at eastern perimeter of Gungahlin Market Place.	One way east to west movement only. Operation not permitted from 7.00am to 9.30 am and 4.30pm to 6.30pm on Monday to Thursday. Operation not permitted from 7.00am to 9.30am and 4.30pm and 9.00pm on Fridays. Operation not permitted from 9.00am to midday on Saturdays. Refer to Restricted Access Route 10 for additional restrictions.

ROUTES APPROVED FOR B-DOUBLES; VEHICLES UP TO 4.6 METRES HIGH AND 14.5 METRE LONG BUSES IN THE AUSTRALIAN CAPITAL TERRITORY

NATIONAL HIGHWAYS & MAIN ROADS INTO ACT	FROM	TO	RESTRICTIONS/CONDITIONS (if applicable)
Hindmarsh Drive (1)	Canberra Avenue	Yamba Drive	
Hindmarsh Drive (2)	Streeton Drive	Eucumbene Drive	Forestry and livestock traffic only between Streeton Dr and Eucumbene Dr.
Hoskins Street	Wells Station Drive	Bellenden Street	
Huddart Court	Entire length (Lysaght St)	(Lysaght St)	
Hume Place	Entire length (Wentworth Ave)	(Wentworth Ave)	
Ipswich Street	Canberra Ave .	Newcastle Street .	Refer to Restricted Route 11 (at the rear of this table) for details .
Isa Street	Entire length (Barrier St)	(Newcastle St)	
Isabella Drive	Entire length (Monaro Hwy)	(Athllon Dr)	
Jenke Circuit	Ampol service station	O'Halloran Circuit	Refer to Restricted Access Route 8 for additional restrictions.
Johns Place	Entire length (Sheppard St)	(end)	
Johnson Drive	Were Street	Drakeford Drive	Westbound one-way traffic only.
Josephson Street	Entire length (Luxton St)	(Nettlefold St)	
Joynton Smith Drive	Entire length (Coulter Dr)	(Benjamin Way)	
Kembla Street	Entire length (Gladstone St)	(Wollongong St)	
Kingsford-Smith Drive	Southern Cross Drive	William Hovell Drive	
Lanyon Drive (1)	Monaro Highway	Sheppard Street	
Lanyon Drive (2)	Monaro Highway	ACT Border	
Lathlain Street	Luxton Street	Nettlefold Street	

ROUTES APPROVED FOR B-DOUBLES; VEHICLES UP TO 4.6 METRES HIGH AND 14.5 METRE LONG BUSES IN THE AUSTRALIAN CAPITAL TERRITORY

NATIONAL HIGHWAYS & MAIN ROADS INTO ACT	FROM	TO	RESTRICTIONS/CONDITIONS (if applicable)
Leeton Street	Entire length (Mildura St)	(Canberra Ave)	
Liardet Street	Macnally Street	Brierly Street (first intersection)	
Lithgow Street	Entire length (Canberra Ave)	(end)	
Long Gully Road	Entire length (Yamba Dr)	(Mugga Ln)	
Lonsdale Street	Entire length (Cooyong Semi-trailer)	(Girrahween St)	Operation not permitted from 8.00am to 9.30am and 4.00pm to 6.30pm on Monday to Friday and operation not permitted from 9.00am to midday on Saturdays.
Luxton Street	Coulter Drive	Lathlain Street	
Lyell Street	Entire length (Barrier St)	(Newcastle St)	
Lysaght Street	Entire length (Hoskins St)	(Flemington Rd)	
McEacharn Place	Entire length (Essington Street)	end	
Macnally Street	Entire length (Namatjira Dr)	(Liardet St)	
Macnaughton Street	Entire Length (Drake-Brockman Dr)	(Starke St)	
Majura Road	Entire length (Federal Hwy)	(Fairbairn Ave)	
Manuka Circle	Canberra Avenue	Canberra Avenue	
Maryborough Street	Entire length (Gladstone St)	(Wollongong St)	
Melrose Drive	Hindmarsh Drive	Athllon Drive	
Mildura Street	Entire length (Canberra Ave)	(Wentworth Ave)	
Morshead Drive	Entire length (Kings Ave roundabout)	(Fairbairn Ave)	
Mort Street	Entire length (Cooyong Semi-trailer)	(Girrahween St)	Operation not permitted from 8.00am to 9.30am and 4.00pm to 6.30pm on Monday to Friday and operation not permitted from 9.00am to midday on Saturdays.
Mouat Street	Entire length (Ginninderra Dr)	(Northbourne Ave)	

ROUTES APPROVED FOR B-DOUBLES; VEHICLES UP TO 4.6 METRES HIGH AND 14.5 METRE LONG BUSES IN THE AUSTRALIAN CAPITAL TERRITORY

NATIONAL HIGHWAYS & MAIN ROADS INTO ACT	FROM	TO	RESTRICTIONS/CONDITIONS (if applicable)
Mountain Road	Railway Street	Oaks Estate Saleyards	Operation by livestock traffic only. (Note that Mountain Rd cannot be accessed via Norse Rd due to a 20 tonne load limit on the railway bridge).
Mugga Lane	Entire length (Hindmarsh Dr)	(Monaro Hwy)	
Mundaring Drive	Entire length (Wentworth Ave)	(The Causeway)	
Namatjira Drive	Streeton Drive	Macnally Street	
Nettlefold Street	Entire length (Coulter Dr)	(Lathlain St)	
Newcastle Street	Monaro Hwy to railway bridge.	Canberra Ave to railway bridge.	
Norman Lindsay Street	Entire length (Tharwa Dr)	(Sidney Nolan St)	
Norse Road	Canberra Avenue	Entrance to Canberra Abattoir	
Northbourne Avenue	Entire length (Federal Hwy)	(Vernon Circle)	
Nyrang Street	Canberra Avenue	Mildura Street	
Oaks Estate Road	Entire length (Pialligo Ave)	(Railway St)	
O'Halloran Circuit	Drakeford Drive	Jenke Circuit	Refer to Restricted Access Route 8 for additional restrictions.
Paddys River Road	Tidbinbilla Road	Laurel Camp Road	Forestry and livestock traffic only
Parkes Way	Coranderrk Street (roundabout)	Kings Avenue (roundabout)	
Pialligo Avenue	Fairbairn Avenue	Yass Road	
Pirie Street	Newcastle Street	Barrier Street	
Point Hut Road	Woodcock Drive	Tidbinbilla Road	Forestry and livestock traffic only.

ROUTES APPROVED FOR B-DOUBLES; VEHICLES UP TO 4.6 METRES HIGH AND 14.5 METRE LONG BUSES IN THE AUSTRALIAN CAPITAL TERRITORY

NATIONAL HIGHWAYS & MAIN ROADS INTO ACT	FROM	TO	RESTRICTIONS/CONDITIONS (if applicable)
Railway Street (1)	Mountain Road	Oaks Estate Road	No access across railway bridge.
(2)	Oaks Estate Road	McEwan Avenue	Local access only – No access to New South Wales.
Randwick Road	Entire length (Northbourne Ave)	(Flemington Rd)	
Raws Crescent	Entire length (Sheppard St)	(Sheppard St)	
Redfern Street	Bindubi Street	Bowman Street (second intersection)	
Sandford Street	Entire length (Gunghalin Dr)	(Flemington Rd)	
Scollay Street	Entire length (Cowlshaw St)	(Athllon Dr)	No left turn into Athllon Dr. Operation not permitted from 7.00am to 9.30 am and 4.30pm to 6.30pm on Monday to Thursday. Operation not permitted from 7.00am to 9.30am and from 4.30pm to 9.00pm on Fridays. Operation not permitted from 9.00am to midday on Saturdays. Refer to Restricted Access Route 3 for additional restrictions.
Sheppard Street	Entire length (Monaro Hwy)	(Lanyon Dr)	
Sidney Nolan Street	Norman Lindsay Street	Balcombe Street	
Sleigh Place	Entire length (Sheppard St)	(end)	

ROUTES APPROVED FOR B-DOUBLES; VEHICLES UP TO 4.6 METRES HIGH AND 14.5 METRE LONG BUSES IN THE AUSTRALIAN CAPITAL TERRITORY

NATIONAL HIGHWAYS & MAIN ROADS INTO ACT	FROM	TO	RESTRICTIONS/CONDITIONS (if applicable)
Southern Cross Drive	Coulter Drive	Kingsford Smith Drive	
Soward Way	Entire length (Erindale Dr)	(Athllon Dr)	Operation not permitted from 7.00am to 9.30 am and 4.30pm to 6.30pm on Monday to Thursday. Operation not permitted from 7.00am to 9.30am and from 4.30pm to 9.00pm on Fridays. Operation not permitted from 9.00am to midday on Saturdays. Refer to Restricted Access Route 3 for additional restrictions.
Starke Street	Macnaughton Street	Unnamed street (connecting Starke Street and Hardwick Crescent)	
State Circle	Entire length (Canberra Ave)	(Canberra Ave)	
Sternberg Crescent	Ashley Drive	Erindale Drive	Operation not permitted between Erindale Dr and Sternberg Cr from 7.30 am to 9.30 am and 4.30 pm to 7.00 pm, Monday to Friday.
Stockdill Drive	Entire length (Drake-Brockman Dr)	(end)	
Streeton Drive (1)	Hindmarsh Drive	Namatjira Drive	
Streeton Drive (2)	Namatjira Drive	Cotter Road	Forestry and livestock traffic only.
Sulwood Drive	Drakeford Drive	Erindale Drive	
Tennant Street	Entire length (Gladstone St)	(Collie St)	
Tharwa Drive	Monaro Highway	Norman Lindsay Street	
The Causeway	Entire length(Mundaring Dr)	(Cunningham St)	
Tidbinbilla Road	Point Hut Road	Paddys River Rd	Forestry and livestock traffic only.
Tooth Street	Entire length (Dacre St)	(Dacre St)	
Townsville Street	Entire length (Albany St)	(Gladstone St)	
Tralee Street	Entire length (Monaro Hwy)	(end)	
Tuggeranong Parkway	Drakeford Drive	Hindmarsh Drive (entry/exit ramps)	
Unnamed street (Holt)	Entire length (Starke St)	(Hardwick Cr)	

ROUTES APPROVED FOR B-DOUBLES; VEHICLES UP TO 4.6 METRES HIGH AND 14.5 METRE LONG BUSES IN THE AUSTRALIAN CAPITAL TERRITORY

NATIONAL HIGHWAYS & MAIN ROADS INTO ACT	FROM	TO	RESTRICTIONS/CONDITIONS (if applicable)
Unnamed street at eastern perimeter of Gungahlin Market Place.	Ernest Cavanagh St	Hibberson St	One way north-south movement only. Operation not permitted from 7.00am to 9.30 am and 4.30pm to 6.30pm on Monday to Thursday. Operation not permitted from 7.00am to 9.30am and 4.30pm and 9.00pm on Fridays. Operation not permitted from 9.00am to midday on Saturdays. Refer to Restricted Access Route 10 for additional restrictions.
Uriarra Road	Entire length (Cotter Rd)	(Brindabella Rd)	Forestry and livestock traffic only.
Vernon Circle	Entire length (Northbourne Ave)	(Northbourne Ave)	
Vicars Street	Entire length (Hoskins St)	(Lysaght St)	
Victoria Street	Gladstone Street, Hall	Barton Highway	Southbound one-way traffic only. Refer to Restricted Access Route 9 for additional restrictions.
Wallaroo Road	Barton Highway	Gladstone Street, Hall	Eastbound one-way traffic only. Refer to Restricted Access Route 9 for additional restrictions.
Wells Station Drive	Entire length (Gungahlin Dr)	(Hoskins St)	
Wentworth Avenue	Entire length (Hume Pl)	(Mundaring Dr)	
Webber Crescent	Entire length (Were St)	(Were St)	Refer to Restricted Access Route 7 for additional restrictions.
Were Street	Entire length (Tharwa Dr)	(Johnson Dr)	No right turn into Johnson Dr. Operation of B-Doubles carrying dangerous goods not permitted from 8.00 am to 4.00 pm, Monday to Friday during school terms. Operation of other B- Doubles not permitted from 8.00 am to 9.00 am and 2.45 pm to 4.00 pm, Monday to Friday during school terms. Refer to Restricted Access Route 7 for additional restrictions.

**ROUTES APPROVED FOR B-DOUBLES; VEHICLES UP TO 4.6 METRES HIGH AND 14.5 METRE LONG BUSES
IN THE AUSTRALIAN CAPITAL TERRITORY**

NATIONAL HIGHWAYS & MAIN ROADS INTO ACT	FROM	TO	RESTRICTIONS/CONDITIONS (if applicable)
Whyalla Street	Entire length (Canberra Ave)	(Newcastle St)	
William Hovell Drive	Kingsford-Smith Drive	Bindubi Street	
William Slim Drive	Entire length (Barton Hwy)	(Ginninderra Dr)	
Wiluna Street	Entire length (Ipswich St)	(Lithgow St)	
Winchcombe Court	Entire length (Sandford St)	(Winchcombe Lane)	
Winchcombe Lane	Entire length (Winchcombe Court)	Heffernan Semi-trailer	
Wollongong Street	Entire length (Gladstone St)	(Newcastle St)	No right turn into Collie Street.
Woolley Street	Entire length (Badham St)	(Cape St)	Refer to Restricted Access Route 2 for restrictions.
Woodcock Drive	Point Hut Road	Drakeford Dr	
Yallourn Street	Entire length (Canberra Ave)	(end)	
Yamba Drive	Hindmarsh Drive	Erindale Drive	

**ROUTES APPROVED FOR B-DOUBLES; VEHICLES UP TO 4.6 METRES HIGH AND 14.5 METRE LONG BUSES
IN THE AUSTRALIAN CAPITAL TERRITORY**

Additional Restricted Access Routes - Access to Specified Sites

1. For access to Shell Service Station, Manuka (Franklin Street):

Left turn from **Canberra Avenue** into **Flinders Way**, left turn into **Franklin Street**, left turn into **Shell Service Station**, left turn into **Canberra Avenue**, left turn into **Flinders Way**, left turn into **Franklin Street**, left turn into **Captain Cook Crescent**, right turn into **Canberra Avenue**.

Operation on this route is **not** permitted at the following times:

Monday to Thursday: 7.00 am - 9.00 am and 4.00 pm - 6.30 pm; Friday: 7.00 am - 9.00 am and 4.00 pm - 10.00 pm.

2. Challis Street, Badham Street, Woolley Street, Cape Streets, Antill Street (between Northbourne Avenue and Badham Street), Dickson:

Vehicles to which this notice applies may only use these streets when accessing ACT Road User Services – Motor Vehicle Registry, Challis Street and Service Stations in this locality.

Vehicles to which this notice applies must conduct a route assessment to determine the most suitable route to access the ACT Motor Registry and the listed service stations.

Operation on these routes is **not** permitted at the following times:

Monday to Thursday: 7.00 am - 9.00 am and 4.00 pm - 6.30 pm; Friday: 7.00 am - 9.00 am and 4.00 pm - 10.00 pm and Saturday from 9.00am to midday.

Route assessments must be approved by the Vehicle Assessment and Technical Unit of the Department of Urban Services.

**ROUTES APPROVED FOR B-DOUBLES; VEHICLES UP TO 4.6 METRES HIGH AND 14.5 METRE LONG BUSES
IN THE AUSTRALIAN CAPITAL TERRITORY**

Additional Restricted Access Routes - Access to Specified Sites

3. For access to Shell Service Station, Tuggeranong Town Centre (Anketell Street):

Left turn from **Anketell Street** into **Shell Service Station**, left turn into **Soward Way**. Vehicles to which this notice applies must conduct a route assessment to determine most suitable route to this location.

Operation not permitted from 7.00am to 9.30 am and 4.30pm to 6.30pm on Monday to Thursday. Operation not permitted from 7.00am to 9.30am and from 4.30pm to 9.00pm on Fridays. Operation not permitted from 9.00am to midday on Saturdays.

4. For access to Shell Service Station, Belconnen (Cohen Street):

Left or right turn from **Lathlain Street** into **Cohen Street**, right turn into **Shell Service Station**, right turn into **Cohen Street**, left or right turn into **Nettlefold Street**.

Operation not permitted from 7.00am to 9.30 am and 4.30pm to 6.30pm on Monday to Thursday. Operation not permitted from 7.00am to 9.30am and from 4.30pm to 9.00pm on Fridays. Operation not permitted from 9.00am to midday on Saturdays.

5. For access to Mobil Service Station, Braddon (Cooyong Street):

Left turn from **Cooyong Street** into **Mobil Service Station**, left turn into **Lonsdale Street**, left turn into **Girrahween Street**, left or right turn into **Northbourne Avenue**.

6. For access to Mobil Service Station, Wanniassa (Ashley Drive):

Left turn from **Ashley Drive** into **Mobil Service Station**, left turn into **Ashley Drive**.

Operation on this route is **not** permitted at the following times:

Monday to Friday: 7.30 am - 9.30 am and 4.30 pm - 7.00 pm.

**Page 16 to the Attachment to the Schedule to the Exemption Notice
made under the Road Transport (Dimensions and Mass) Act 1990**

**ROUTES APPROVED FOR B-DOUBLES; VEHICLES UP TO 4.6 METRES HIGH AND 14.5 METRE LONG BUSES
IN THE AUSTRALIAN CAPITAL TERRITORY**

Additional Restricted Access Routes - Access to Specified Sites

7. For access to Ampol Service Station, Calwell (Were Street):

Right turn from **Were Street** into **Webber Crescent**, (either intersection), left or right turn into **car park**, left turn into **Ampol Service Station**, left turn into **Were Street**.

Operation on this route is **not** permitted at the following times:

Monday to Friday (during School terms): 8.00 am - 4.00 pm.

8. For access to Ampol Service Station, Kambah (O'Halloran Circuit):

Left or right turn from **Drakeford Drive** into **O'Halloran Circuit**, left turn into **Ampol Service Station**, right turn into **Jenke Circuit**, right turn into **O'Halloran Circuit**, left or right turn into **Drakeford Drive**.

Operation on this route is **not** permitted at the following times:

Monday to Friday (during School terms): 8.00 am - 4.00 pm.

9. For access to Canberra Carways Pty Ltd depot, Hall (Gladstone Street):

Left or right turn from **Barton Highway** into **Wallaroo Road**, straight ahead into **Gladstone Street**, left turn into **Canberra Carways Pty Ltd depot**, left turn into **Gladstone**

Street, right turn into **Victoria Street**, left or right turn into **Barton Highway**.

10. For movement in Gungahlin Market Place:

One way west to east movement only on Ernest Cavanagh Street at any point past the Woolworths loading bay; one way north to south movement only on Unnamed street at eastern perimeter of Gungahlin Market Place.

**ROUTES APPROVED FOR B-DOUBLES; VEHICLES UP TO 4.6 METRES HIGH AND 14.5 METRE LONG BUSES
IN THE AUSTRALIAN CAPITAL TERRITORY**

Additional Restricted Access Routes - Access to Specified Sites

11. For movement in Fyshwick Industrial area.

The following restrictions apply in this area:

- Barrier Street:
No right turn onto Ipswich St;
- Woolongong Street:
No right turn into Collie Street.

**Page 18 to the Attachment to the Schedule to the Exemption Notice
made under the Road Transport (Dimensions and Mass) Act 1990**

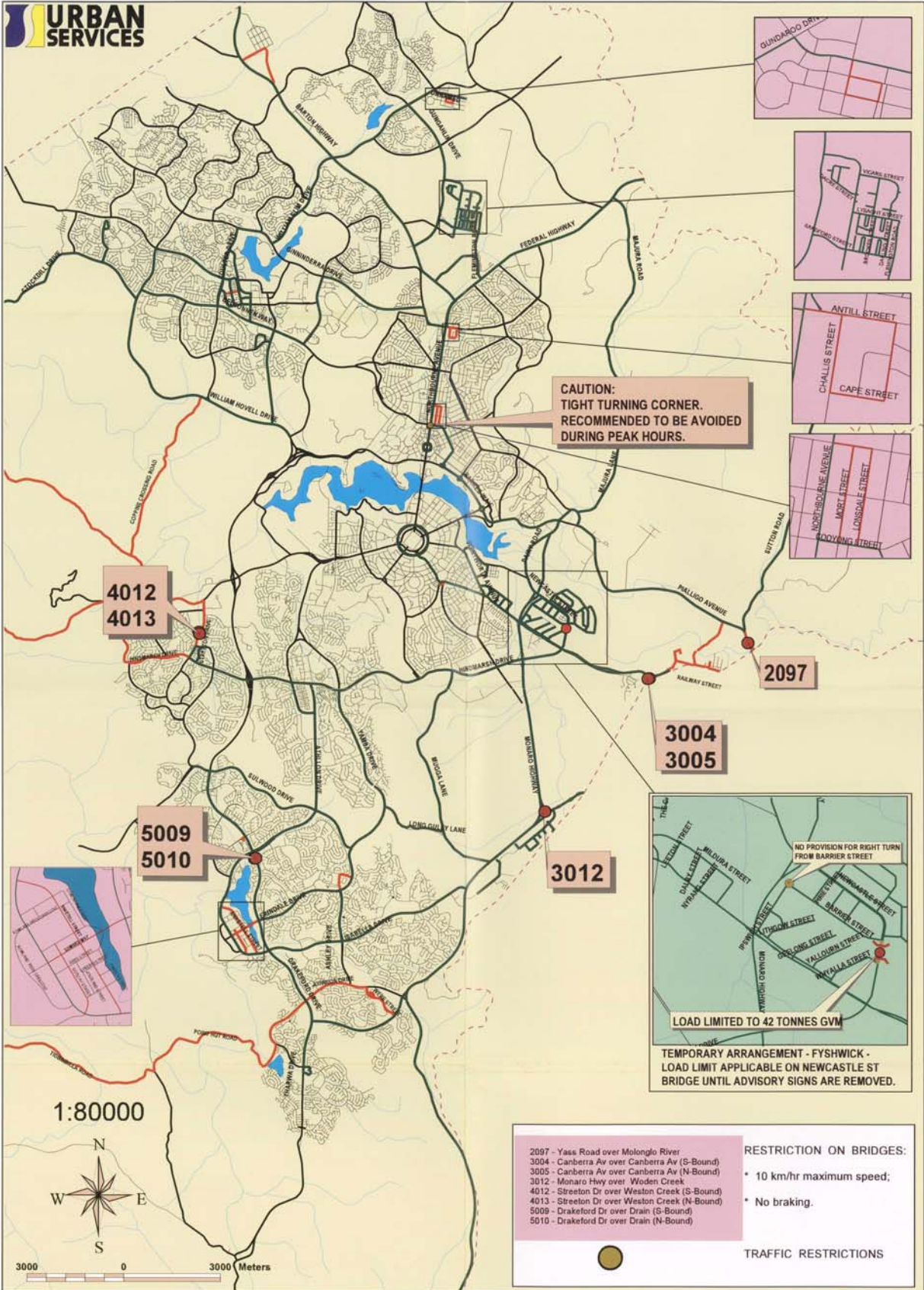

APPROVED ACT ROUTES FOR:

- * 62.5 TONNE B-DOUBLES;
- * 4.6 METRE HIGH VEHICLES; AND
- * 14.5 METRE LONG BUSES.

LEGEND

- Bridge with Restrictions
- Approved Routes
- Routes with Special Conditions
- Other Roads
- Waters
- ACT Boundary