

Work Safety (National Code of Practice for the Prevention of Falls in Housing Construction) Code of Practice 2010

Disallowable instrument DI 2010 – 237

made under the

Work Safety Act 2008, section 18 (Codes of Practice)

1 Name of instrument

This instrument is the *Work Safety (National Code of Practice for the Prevention of Falls in Housing Construction) Code of Practice 2010*

2 Commencement

This instrument commences on 1 October 2010.

3 Approval of a code of practice

Under section 18 of the *Work Safety Act 2008*, having consulted with the ACT Work Safety Council, I approve the National Code of Practice for the Prevention of Falls in Housing Construction as a code of practice.

Katy Gallagher
Minister for Industrial Relations
3 September 2010



safe work australia

NATIONAL CODE OF PRACTICE FOR THE PREVENTION OF FALLS IN HOUSING CONSTRUCTION



April 2010



© Commonwealth of Australia 2010

ISBN 978 0 642 32973 8 (Online PDF)

This work is copyright. You may download, display, print and reproduce this material for your personal, non-commercial use or use within your organisation, provided that an appropriate acknowledgement is made (retaining this notice), and the material is not altered or subjected to derogatory treatment. Apart from any use as permitted under the Copyright Act 1968, all other rights are reserved. Requests and inquiries concerning reproduction and rights should be addressed to:

Commonwealth Copyright Administration
Attorney-General's Department
3-5 National Circuit
Barton ACT 2600
Email: commonwealth.copyright@ag.gov.au
Web: www.ag.gov.au



FOREWORD

Safe Work Australia, in partnership with governments, employers and employees, leads and coordinates national efforts to prevent workplace death, injury and disease. Safe Work Australia develops national policy on work health and safety (WHS) and workers' compensation matters, building on the work carried out by its predecessor organisation the Australian Safety and Compensation Council (ASCC) and ASCC's predecessor, the National Occupational Health and Safety Commission (NOHSC).

Through the Council of Australian Governments (COAG), the Australian Government has made the commitment to work cooperatively with state and territory governments to achieve the harmonisation of work health and safety laws. On 3 July 2008 COAG signed the *Inter-Governmental Agreement for Regulatory and Operational Reform in Occupational Health and Safety*, committing to the development of model work health and safety laws and its adoption into all jurisdictions by December 2011.

Safe Work Australia is committed to its Strategic Plan 2009-2012 that was agreed in June 2009. This builds on the plan developed by NOHSC (the National OHS Strategy 2002-2012). The Strategic Plan sets out three objectives. These are to:

- achieve national uniformity of the WHS legislative framework complemented by a nationally consistent approach to compliance policy and enforcement policy;
- achieve significant and continual reductions in the incidence of death, injury and disease in the workplace; and
- educate and inform the community of WHS and workers' compensation issues.

The Strategic Plan also sets out required outcomes. These are:

- harmonise work health and safety laws by December 2011;
- meet the national targets set out in the National OHS Strategy;
- educate and inform the community of WHS and workers' compensation issues; and
- develop a national action plan to commence harmonising workers' compensation arrangements.

In March 2003 the Final Report of the Cole Royal Commission into the Building and Construction Industry concluded that 'From the perspective of the building and construction industry, there could be no more salutary reform to WHS law and regulation than a single national scheme comprehensively regulating WHS throughout Australia'. The Workplace Relations Ministers' Council (WRMC) recognised the high incidence and severity of injuries in the Construction industry and the resulting costs to governments, industry and the general community, and in November 2003 agreed that NOHSC would develop national material for the Construction industry.

The *National Standard for Construction Work [NOHSC: 1016 (2005)]* (National Standard) was declared by NOHSC in April 2005. The National Standard promotes a uniform national approach to the management of WHS in the construction industry. It was agreed that jurisdictions would have an implementation period of two years for general construction and three years for housing construction. At this time it was also agreed that national Codes of Practice would be developed to support the National Standard

The *National Code of Practice for the Prevention of Falls in General Construction* was declared by the ASCC in April 2008. This code provides practical guidance to the general construction sector on ways to eliminate and/or minimise the risk of falls from height.



The *National Code of Practice for the Prevention of Falls in Housing Construction*, referred to in this document as the National Code, was declared by Safe Work Australia in April 2010. This National Code provides practical guidance for employers and employees on ways to effectively manage the risks associated with working at height in the housing construction sector and prescribes circumstances in which the provision of physical fall prevention measures are required, where reasonably practicable.

The National Code was developed by the ASCC before work commenced on the model work health and safety legislation. It will provide guidance to those working in the housing construction sector until the work health and safety legislative framework is implemented on 1 January 2012.

The National Code is an advisory document. Each jurisdiction will make a decision on the adoption of the National Code.

Safe Work Australia acknowledges those who have assisted in the development of this National Code, including representatives from the Commonwealth, state and territory governments, unions and industry.



CONTENTS

PART 1	7
1.1 TITLE	7
1.2 PURPOSE	7
1.3 SCOPE AND APPLICATION	7
1.4 STATE AND TERRITORY REQUIREMENTS	8
1.5 DUTY HOLDER RESPONSIBILITIES	8
1.6 WHAT ARE THE DUTIES WHEN WORKING AT A HEIGHT OF LESS THAN 2 METRES?	8
1.7 WHAT ARE THE DUTIES WHEN WORKING AT A HEIGHT OF 2 METRES OR MORE?	8
1.8 INFORMATION, INSTRUCTION AND TRAINING	9
PART 2 FALLS FROM 2 METRES AND ABOVE	10
2.1 FALL PROTECTION MEASURES	10
2.1.1 Hierarchy of control	10
2.1.2 Reasonably practicable	10
2.2 LEVEL 1 CONTROLS	11
2.2.1 Work on the ground	11
2.2.2 Work from solid construction	11
2.3 LEVEL 2 CONTROLS: PASSIVE FALL PREVENTION DEVICES	13
2.3.1 Temporary work platforms	13
2.4 LEVEL 3 CONTROLS: WORK POSITIONING SYSTEMS	20
2.4.1 Travel restraint systems	20
2.5 LEVEL 4 CONTROLS: FALL-ARREST SYSTEMS	20
2.5.1 Catch platforms	20
2.5.2 Individual Fall-Arrest Systems	21
2.5.3 Safety nets	21
2.6 LEVEL 5 CONTROLS: USE OF PORTABLE LADDERS AND ADMINISTRATIVE CONTROLS	22
2.6.1 Portable ladders	22
2.6.2 Administrative controls	27



2.7 SAFE WORK METHODS FOR COMMON TASKS	27
2.7.1 Floor laying	28
2.7.2 Fixing ceiling joists and upper level floor joists	30
2.7.3 Guarding openings	30
2.7.4 Wall framing	31
2.7.5 Installing prefabricated timber roof trusses	32
2.7.6 Constructing conventional or stick roof	39
2.7.7 Fixing roof battens to trusses	39
2.8 ROOFING TASKS	41
2.8.1 Risk controls - General	41
2.8.2 Critical angle	41
2.8.3 Access and egress	41
2.8.4 Guardrail systems for roofing work	41
2.8.5 Catch platforms	43
2.8.6 Steep roofs	43
2.8.7 Installation of sarking – tile roofing	44
2.8.8 Installation of perimeter battens – metal roofing	44
2.8.9 Fixing fascias and gutters	44
PART 3 FALLS FROM BELOW 2 METRES	45
3.1 RISK ASSESSMENT	45
3.2 PREVENTING FALLS OF LESS THAN 2 METRES	46
3.2.1 Portable ladders	47
3.2.2 Ladder bracket scaffolds	47
4. DEFINITIONS	48
APPENDIX A REFERENCED DOCUMENTS AND FURTHER READING	52
APPENDIX B OHS AUTHORITIES	54
APPENDIX C TIMBER SCAFFOLDS	56



PART 1

1.1 TITLE

This document may be cited as the *National Code of Practice for the Prevention of Falls in Housing Construction* (referred to in this document as the National Code).

1.2 PURPOSE

This National Code is part of a package of WHS material supporting the *National Standard for Construction Work* [NOHSC (1016: 2005)] (referred to in this document as the National Standard). The National Code provides practical guidance and advice to persons working in the housing construction industry on ways to eliminate, or if that is not possible, minimise the risk of falls from height in housing construction work. The National Code prescribes circumstances in which the provision of physical fall prevention measures is required, so far as is reasonably practicable. Where the National Code provides advice on one or more acceptable means of doing a task, it does not preclude the use of other methods that provide an equal or better risk control.

1.3 SCOPE AND APPLICATION

The National Code provides guidance on adopting a risk management approach to fall prevention for working at heights of less than 2 metres, as well as guidance on risk assessment processes and examples of physical fall prevention measures that are required when working at a height of 2 metres or more, so far as is reasonably practicable.

The National Code seeks to endorse the provision of physical fall protection for all persons working at a height of 2 metres or more, where reasonably practicable. However, the National Code does outline some tasks where other fall protection may be provided, where it is not considered reasonably practicable to provide physical fall protection.

Note: Guidance provided in the boxed text and in the appendices to this National Code is to be considered part of this National Code.

This National Code applies to the construction or extension of:

- a. detached houses
- b. attached dwellings, separated from each other by a fire resisting wall, such as terrace, row or town houses
- c. boarding and guest houses, hostels or similar with a floor area <300m², and
- d. ancillary buildings to the above, such as private garages, gazeboes and carports.



Note: Points a - d are based on Classes 1, 2 and 10 of the Building Code of Australia. Multi-storey buildings, i.e. above three habitable storeys, are not included in the scope of this National Code.

This National Code does not apply to the maintenance or renovation of buildings.

This National Code can be used to develop specific workplace and industry programs for the control of risks associated with working at height in the housing construction industry.

The National Code refers only to trenching and excavating insofar as they pose a fall hazard. These areas are covered in more detail in jurisdictional regulations.

For further guidance on jurisdictional requirements and specific guidance material relating to fall hazards in housing construction, contact your local OHS authority.

Persons working in general construction should refer to the *National Code of Practice for the Prevention of Falls in General Construction*.

1.4 STATE AND TERRITORY REQUIREMENTS

All persons involved in housing construction must comply with the relevant WHS legislation administered by state and territory OHS authorities.

1.5 DUTY HOLDER RESPONSIBILITIES

An important element in the prevention of falls in housing construction work is a clear understanding by all parties about who has responsibilities in relation to fall prevention, and how those responsibilities can be met. For more information about who has a duty to prevent a fall refer to the National Standard.

1.6 WHAT ARE THE DUTIES WHEN WORKING AT A HEIGHT OF LESS THAN 2 METRES?

In situations where persons are working at heights where there is a risk of falling less than 2 metres, the standard risk management model of identifying fall hazards, assessing the risk of a fall occurring, and controlling the risks should be adopted.

Information on working at heights of less than 2 metres can be found at Part 3 of this National Code.

1.7 WHAT ARE THE DUTIES WHEN WORKING AT A HEIGHT OF 2 METRES OR MORE?

This Code requires where there is a risk that someone undertaking housing construction work could fall 2 metres or more, the person with control of a construction project or construction work is required to ensure that:

- hazards, including hazards other than fall hazards, have been identified
- where reasonably practicable, physical fall protection is provided

- 
- other hazards have been controlled, and
 - after a risk assessment has identified what controls are needed, a Safe Work Method Statement (SWMS) is developed for the work which details the control measures to be used.

1.8 INFORMATION, INSTRUCTION AND TRAINING

Everyone working on a residential construction work site must be provided with sufficient information, instruction and training to enable them to work safely and without risking their health. This can include site and task induction.

Where workers are exposed to potential falls from working at any height, information, instruction and training must explain:

- the hazards and risks associated with work performed at these heights
- how to follow health and safety procedures associated with this work, and
- the reasons fall protection measures have been set in place and how to use them properly.

Those supervising the work must also receive training.

The amount and type of information, instruction and training required will depend on the risk involved, the complexity of the work procedures and the type of fall protection measures used.



PART 2 FALLS FROM 2 METRES AND ABOVE

2.1 FALL PROTECTION MEASURES

This section provides detailed guidance on practicable fall protection measures appropriate for a range of typical activities in housing construction. The guidance is set out in the order of the hierarchy of control. This Code requires that wherever it is reasonably practicable to do so, controls at the top of the hierarchy must be implemented before consideration is given to implementing lower order controls.

Fall protection measures must also be suited to the particular task, the severity of risk (which includes how serious the consequences may be) and the employees involved.

2.1.1 Hierarchy of control

- Level 1: Undertake the work on the ground or on solid construction.
- Level 2: Undertake the work using a passive fall prevention device.
- Level 3: Undertake the work using a work positioning system.
- Level 4: Undertake the work using a fall-arrest system.

If after considering all of the control measures listed above a risk remains, and there is no reasonably practicable alternative, you must use the following forms of control:

- Level 5: Undertake the work from ladders, or implement administrative controls.

2.1.2 Reasonably practicable

'Reasonably practicable' is a concept which takes into account a number of factors that can help you decide what is reasonable in terms of controlling risks, such as a fall from height. Depending on where you work in Australia, it can have different meanings, so also check jurisdictional requirements.

'Reasonably practicable' does not just mean the cost in dollar terms. To determine what is reasonably practicable, the following issues may be taken into consideration:

Severity of the hazard or risk

How likely is it that a worker will fall? How serious are the injuries likely to be? If each time a worker is exposed to an uncontrolled risk which may result in severe injury or death, then this is an important factor.

State of knowledge

What is known about the hazard and the ways of controlling the risk? How do similar businesses or workplaces control the risk of falling? What information can WHS professionals, industry associations, unions and government bodies provide? What can you find out from manufacturers and suppliers about risk control equipment?

Availability and suitability of ways to remove or mitigate the hazard or risk

Are the fall protection measures you have identified available? Are they designed and constructed for the work site, the task and all people using them? Manufacturers/suppliers instructions should be noted prior to commencing tasks. Duty holders may include these instructions in risk assessment documentation.



The cost of removing or mitigating the hazard or risk

What are the costs of eliminating or reducing the hazard or risk, now and in the future?

2.2 LEVEL 1 CONTROLS

2.2.1 Work on the ground

Eliminating the need to work at height is the most effective way of protecting workers from fall hazards. It is worth considering how the work could be done without exposing yourself or other workers to the risk of falling from a height or into a depth greater than 1.5 metres, consistent with the National Standard's definition of high-risk construction work.

2.2.2 Work from solid construction

Where work is being done from solid construction, workers are provided with an environment where the likelihood of a fall is minimised. 'Solid construction' means an area that:

- is structurally capable of supporting workers, material and any other loads applied to it
- is provided with guardrailing around its perimeter and all open penetrations from or through which workers could fall
- has an even, accessible surface and gradient, and
- allows workers to enter and leave the work area safely.

This Code requires that solid construction satisfies all of the following requirements:

Structural strength

Different types of work involve different loads on the supporting surface. Make sure that the surface and its supports can safely carry the expected loads, including workers, materials, tools and equipment. When in doubt, have a structural engineer determine the safe load capacity before use.

Ensure that where props are used to support suspended floors, formwork or similar areas that:

- proprietary brand props are marked with their safe working load
- the props are designed for the loads imposed, and
- the props are tied to each other in the longitudinal and transverse directions to form a stable, free-standing structure.

Surface and gradient

Surfaces of solid construction need to be non-slip and free from trip hazards and traps.

Surfaces of solid construction should generally not exceed 7 degrees (1 in 8 gradient). Cleated surfaces which provide greater slip resistance, should not be steeper than 20 degrees (1 in 3 gradient).

Note: Work from greater slopes may be acceptable where a specific risk assessment is carried out for that task and appropriate controls are implemented.



Edge protection

Perimeter protection must be provided on the exposed edges of a solid construction. These include:

- the perimeters of buildings or other structures
- the perimeters of skylights or other fragile roof materials, and
- openings in floor or roof structures.

Edge Protection Checklist

As per the requirements of AS 4576 and AS 4994:

- the guard rail system must be of robust design and able to withstand the force of someone falling against it
- top rails must be between 900mm and 1100mm above the working surface
- midrails must be provided. However, wire mesh infill panels incorporating a toeboard may be used instead of the midrail
- toeboards must be provided where reasonably practicable
- a bottom rail above the toeboard on some roof slopes may be provided for more severe roof slopes. Both a midrail and infill mesh panel will assist in preventing persons and objects from sliding off the roof
- if access points are required for equipment (e.g. tile elevators) they must be protected adequately to prevent a person falling, and
- every open edge of a stair, landing, platform or shaft opening must be protected to prevent people falling.

Note: Refer to AS 1657 and AS 1567 for further requirements for edge protection.

Void protection

Where workers are working from trestles, ladders and mobile scaffolds on solid construction and they are located in close proximity to floor openings such as stairwells and partially completed floors, edge protection will not prevent a fall into the opening. The openings must be covered and the covers must be capable of withstanding any impact and static loads, and must be fixed to prevent any dislodgement or accidental removal.

Access and egress

Every solid construction must have safe and suitable means of access and egress, such as:

- existing floor levels
- permanently installed platforms, ramps, stairways and fixed ladders complying with the relevant Australian Standards
- temporary access ways and temporary stair systems, and
- secured single portable ladders set up at a slope of 4:1 and extending at least 1 metre above the stepping off point.

Stepladders and trestle ladders should not be used for access to, or egress from, solid construction.



2.3 LEVEL 2 CONTROLS: PASSIVE FALL PREVENTION DEVICES

A 'passive fall prevention device' is any fall protection system that once erected or installed requires no further ongoing adjustment, alteration or operation by a worker to ensure the integrity of the system to perform its function as a fall prevention system. Examples include temporary work platforms and guardrails.

2.3.1 Temporary work platforms

A 'temporary work platform' is a working platform, other than a permanently installed fixed platform, used to provide a working area for the duration of the job. The design of the platform prevents workers from falling. Temporary work platforms commonly used in housing construction include scaffolds (fixed or mobile), elevating work platforms and step platforms.

2.3.1.1 Scaffolds

Scaffolds are a common means of providing a safe platform for working at height. There is a wide variety of scaffold systems available.

Scaffold working platforms are generally rated as light, medium or heavy duty:

- Light Duty – up to 225 kg per bay. Examples include painting, electrical work, many carpentry tasks and other light tasks. Platforms should be at least two planks wide (approximately 450mm)
- Medium Duty – up to 450 kg per bay. This is suitable for general trades work. Platforms should be at least four planks wide (approximately 900mm)
- Heavy Duty – up to 675 kg per bay. This is what is needed for bricklaying, concreting, demolition work and most other work tasks involving heavy loads or heavy impact forces. Platforms should be at least 5 planks wide (approximately 1000mm)
- Special Duty – has a designated allowable load as designed.

These safe load limits include the weight of people (which is taken to be a nominal 80 kg¹) plus the weight of any materials, tools and debris on the working platform. Therefore, a properly constructed mobile scaffold with a light duty platform can safely support one worker and 145 kg of tools and material, or two workers and 65 kg of tools and materials.

Requirements for erecting, altering or dismantling scaffolds vary depending where you work in Australia. This Code requires you to check local regulations to make sure the person working with the scaffolding has appropriate qualifications or licensing.

Information, instruction and training for workers using scaffolds

Where work is performed from a scaffold, ensure that the relevant workers know:

- what loads it can safely take (Safe Working Load (SWL))
- that unauthorised alterations must not be made to the scaffold (such as removing guardrails, planks, ties, toeboards and braces)
- that working platforms need to be kept clear of debris and obstructions along their length, and
- that incomplete or defective scaffolds must never be accessed.

¹ The current review of the Australian Standard series for scaffolding may result in the nominal weight of a person being increased.



Where mobile scaffolds are in use, the scaffold must:

- remain level and plumb at all times
- be kept well clear of powerlines, open floor edges and penetrations
- never be accessed until all castors are locked to prevent movement, and
- never be moved while anyone is on the scaffold.

2.3.1.2 Ladder bracket scaffolds

The use of ladder brackets to support planks is not an acceptable means of providing fall protection for persons working at 2 metres or above. Advice on the use of ladder bracket scaffolds when working below 2 metres is given in Part 3.2.2.

2.3.1.3 Trestle scaffolds

Trestle scaffolds are generally not suitable for working at 2 metres or above. If they are used at heights greater than 2 metres, guardrailing should be used so as to prevent persons from falling off the open side or end of the work platform (see Figure 1). The system (including planks) must be assembled according to the manufacturer's specifications.

Some trestle ladder scaffolds include outriggers. Trestle ladder scaffolds are only suited to light duty tasks, such as painting and rendering.

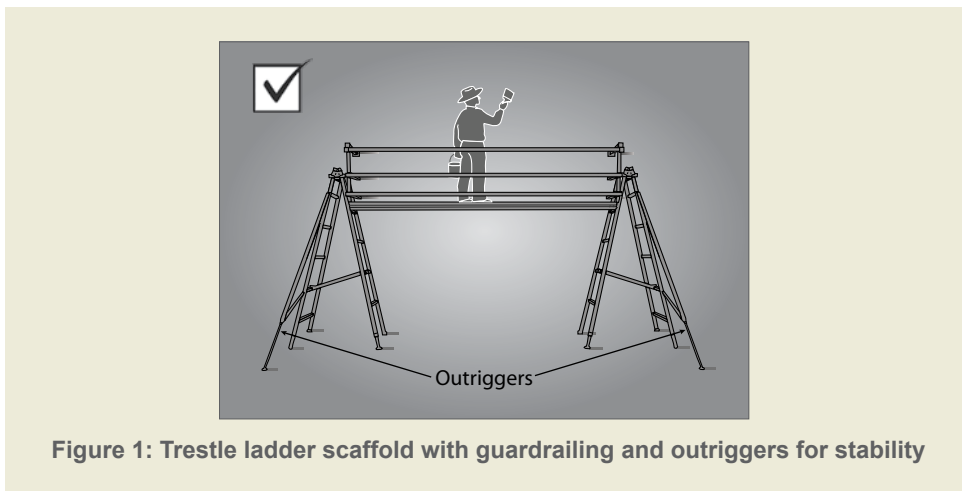
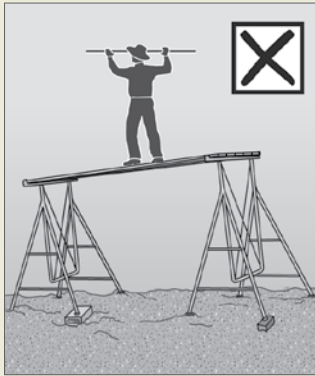

Figure 1: Trestle ladder scaffold with guardrailing and outriggers for stability

When adjusting the height of a brick layer's trestle scaffold, make sure that only the purpose designed pins are used. Do not use nails or pieces of reinforcing bar.

Work must only be performed between the trestles. Where a trestle scaffold is more than one bay in length, heavy loads must be placed directly over the trestles.



(a) Trestle scaffold set up on uneven, sloping ground with unsuitable soleplates

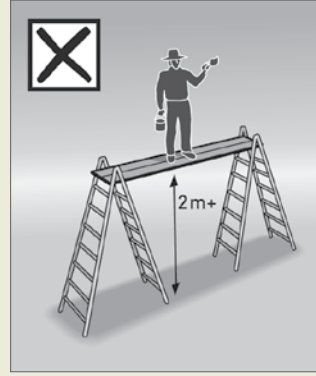

(b) Worker could fall more than 2 metres

Figure 2: Examples of wrongly used trestle scaffolds

Scaffolding checklist

Safety requirements and considerations include:

- scaffolding must conform to AS/NZS 4576 and the AS/NZS 1576 series
- if scaffolding is to be erected from which a person or object could fall more than 4 metres, the scaffold must be erected, altered and dismantled by a licensed scaffolder
- an unlicensed person must not alter scaffolding without authority from a competent person
- prefabricated scaffolds must be of the same type and not mixed components, unless the mixing of components has been approved by the manufacturer. AS/NZS 4576 sets out the assurances that are needed before the components of different prefabricated scaffolding systems can be mixed in a scaffold. Unauthorised mixing of components from different manufacturers has resulted in scaffold incompatibilities and failures, posing significant risks to persons using the scaffolding
- mobile tower frame scaffolds can be used to provide safe working platforms
- scaffolding that is incomplete and left unattended must have danger tags and warning signs attached at appropriate locations to prevent use
- scaffolding exceeding a deck height of 4 metres must be inspected and tagged by a competent person before use, after any alteration or repair, and at intervals not greater than 30 days
- only a licensed person or a trainee under direct supervision of a licensed person may modify the height of a scaffold exceeding a deck height of 4 metres
- additional inspections must be carried out by a competent person following an occurrence such as a severe storm or earthquake
- safe access to and egress from the scaffold must be provided, and
- edge protection must be provided at every open edge of a work platform.



2.3.1.4 Elevating work platforms

Elevating work platforms (EWPs) include scissor lifts, cherry pickers, boom lifts and travel towers. There are battery powered and internal combustion engine types. Some are designed for hard flat surfaces only, while others are designed to be operated on rough terrain.

Persons working in travel towers, boom lifts or cherry pickers must wear a properly anchored safety harness. Persons working in scissor lifts are not required to wear a safety harness.

Information, instruction and training for workers using EWPs

Workers using EWPs must be trained and instructed in the safe loading and safe operating procedures for the particular brand and type of plant. Workers must also be licensed when operating boom lifts with a boom length of 11 metres or more.

Elevating Work Platform checklist

The safety requirements include:

- workers operating the platform must be trained and instructed in safe operating procedures for the particular brand and type of equipment
- the platforms should only be used as working platforms. They should not be used as a means of access to and egress from a work area unless the conditions set out in AS 2550.10 are met
- unless designed for rough terrain, the platforms must be used only on a solid level surface
- the surface area must be checked to make sure that there are no penetrations or obstructions which could cause uncontrolled movement or overturning of the platform
- when designed as rough terrain platforms, the manufacturer's/suppliers' instructions should be consulted for information on safe operation
- the training provided must include safe use of the fall-arrest equipment and emergency rescue procedures, and
- people working in cherry pickers must wear an anchored safety harness and lanyard incorporating a shock absorber as precaution against mechanical failure of the basket. The lanyard should be as short as possible.



2.3.1.5 Step platforms

Commercially available step platforms are stable and provide a much larger work surface than a stepladder. Some models are collapsible and adjustable to heights above 2 metres.

2.3.1.6 Perimeter guardrailing

Guardrailing may be used to provide effective fall protection at:

- the perimeters of buildings or other structures
- the perimeters of skylights or other fragile roof materials
- openings in floor or roof structures, and
- edges of excavations.

Guardrailing must:

- incorporate a top rail 900mm-1100mm above the working surface
- incorporate a midrail
- incorporate a toeboard (except where it may be impractical to do so) and alternative control measures, such as 'no go' zones, to ensure no persons are at risk of being hit by falling objects from the work above, and
- be of robust construction and designed in accordance with the relevant Australian Standards.

Wall framing incorporating studs at 600mm centres and one row of noggings is an acceptable alternative to guardrailing. Where the frame incorporates window or door openings additional members must be fitted across these openings which provides the equivalent fall protection to the guardrailing described above.

Proprietary systems must be configured, installed, used and dismantled according to the manufacturer's/suppliers' instructions.

Where timber guardrailing is not specifically designed in accordance with AS 1657, the member sizes set out below may be used for guardrail and post sizes respectively.

TIMBER GUARDRAILS		
Guardrail size depth x width (nominal sizes) (mm)	Maximum guardrail span (m)	
	F8 HW or MGP 12 seasoned pine	F7 pine
100 x 38	2.7	NA
100 x 50	3.5	NA
2 nos 90 x 35)**	NA	3.5
**Timber members to be nailed together at maximum 300 mm intervals in 'T' or 'L' sections		

Wherever feasible, guardrailing should be constructed so that when an outward force is applied the posts are subjected to bending about their strong axis (see Figure 3).

The manufacturer/supplier of proprietary guardrailing systems must provide the detail and instructions.



Building timber must be inspected by a person with relevant qualifications or experience to determine whether it is suitable for use as guardrailing. The methods for connecting timber posts to the support structure or rails to posts must have adequate strength for the purpose intended (Figure 3 gives two connection detail examples).

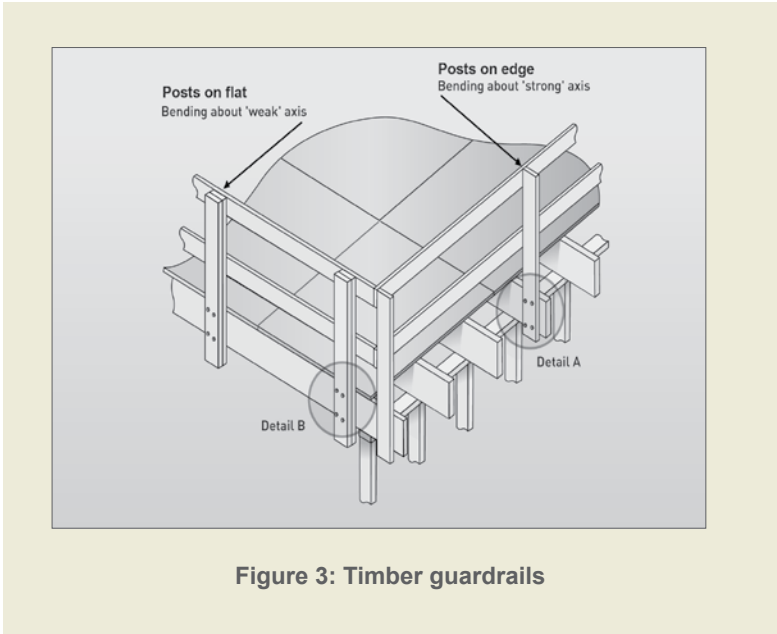
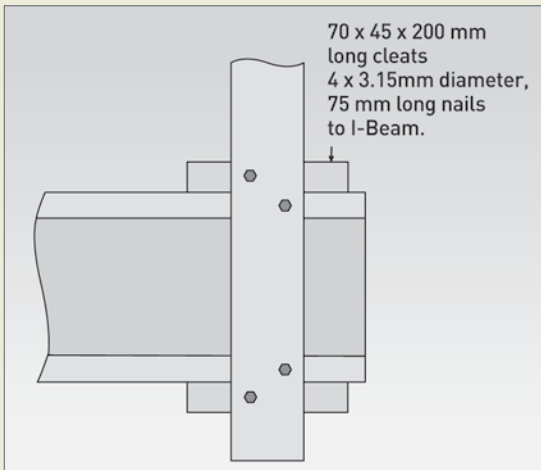
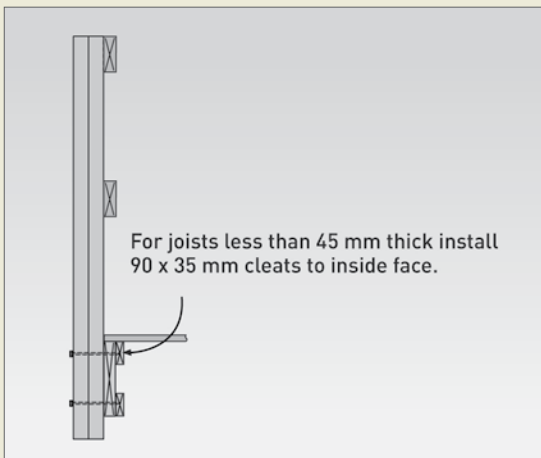
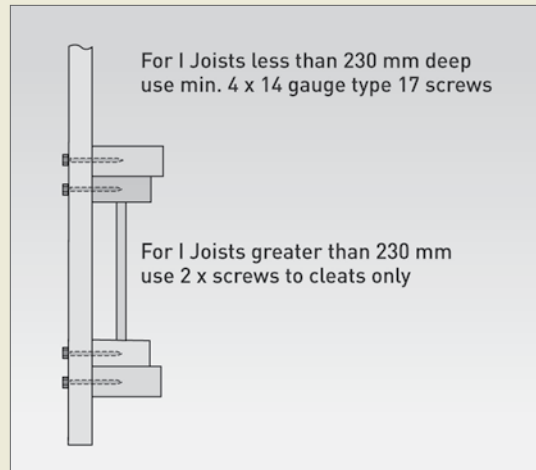

Figure 3: Timber guardrails



Detail 'A' Bending about strong axis: I-Beam joists



Detail 'B' Bending about weak axis

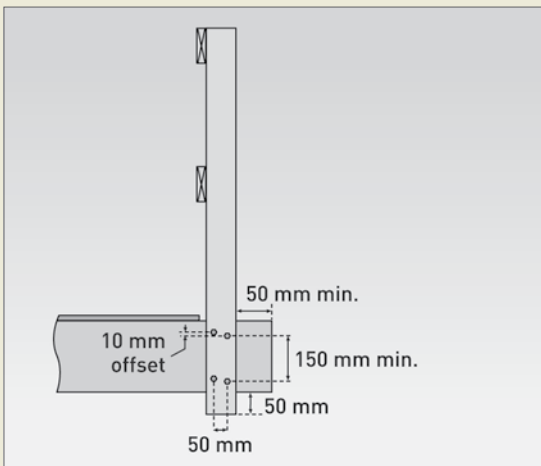
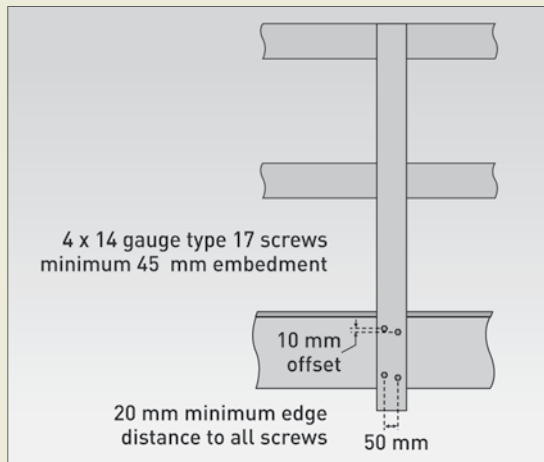

Detail 'A' Bending about strong axis: solid floor joists

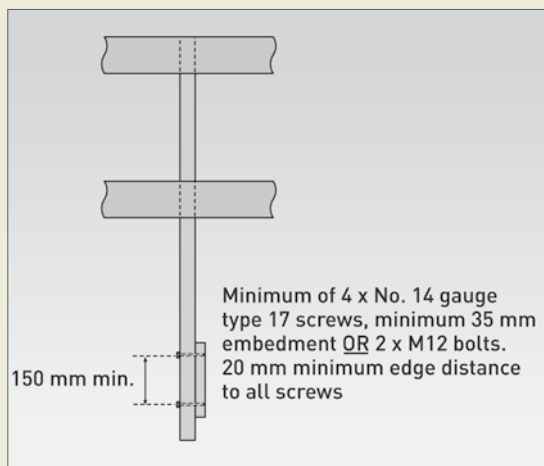



2.3.1.7 Guardrails for trenching works

Where trenching works present a risk of a person falling 2 or more metres on site, any such risk may be controlled by:

- the provision of guardrailing, or where possible
- the provision of a barrier, approximately 1.5 metres back, to prevent persons approaching the trench.

2.4 LEVEL 3 CONTROLS: WORK POSITIONING SYSTEMS

A 'work positioning system' is equipment, other than temporary work platforms, that enables a worker to be positioned and safely supported at a work location to carry out a task.

2.4.1 Travel restraint systems

A travel restraint system prevents the user from approaching an unprotected edge on a building or structure. Generally, the system consists of a safety harness connected by a lanyard to a suitable anchorage point or static line. This equipment must be set up to prevent the worker from reaching an edge from where a fall may occur.

A purpose-designed roof anchor, when used in accordance with the manufacturer's/suppliers' instructions, may be used as part of a travel restraint system on metal deck or tiled roofs and should only be used for tasks of short duration.

Travel restraint systems must **only** be used if it is not reasonably practicable to adopt a fall protection system that prevents falls by providing a physical barrier (such as guardrailing). This is because travel restraint systems require a high level of user skill to operate safely and require greater supervision. If using travel restraint systems, training and supervision is mandatory.

Travel restraint systems are not fall-arrest devices. Typical anchorage points for these systems are not designed for the impact loads applied in the event of a fall. Therefore, where there is any possibility that a person using a travel restraint device may approach an edge from where a fall is possible, a travel restraint system must not be used. Consequently, inertia reels and retractable lanyards are not to be used as they do not restrict travel and can allow the worker to fall.

2.5 LEVEL 4 CONTROLS: FALL-ARREST SYSTEMS

A fall-arrest system means equipment intended to reduce the severity of an injury to a person if a fall does occur. These systems include catch platforms, individual fall-arrest systems and industrial safety nets.

2.5.1 Catch platforms

A catch platform is a temporary platform located below a work area to catch a worker in the event of a fall. The platform must be designed to sustain the maximum potential impact load.

This Code requires that all catch platforms:

- incorporate a fully planked deck
- be positioned so as to maintain a minimum of 2 metres beyond all unprotected edges of the work



area, except where extended guardrailings is fitted to the catch platform, and

- be positioned as close as possible to the underside of the work area, and in no case be greater than 1 metre below the work area.

Heavy duty trestle scaffolds can be used as simple and inexpensive catch platforms, particularly in voids and stairwells.

2.5.2 Individual Fall-Arrest Systems

Individual fall-arrest systems (IFAS) are intended to arrest a falling person safely and reduce the impact of the fall. If using IFAS, training and supervision is mandatory. The safe and correct use of IFAS relies on many factors, including the design and availability of substantial engineered anchorage points. IFAS have limited application in housing construction because:

- they require ongoing supervision and are awkward and cumbersome to use on residential roofs
- they are generally appropriate for work at heights over 6.5 metres (workers in residential construction would generally strike the ground before the system properly deploys)
- it is often difficult to achieve the minimum required 15kN anchorage point rating on a timber roof (particularly when only partially completed)
- workers are susceptible to tripping caused by the lanyard fouling on roof components, and
- IFAS must only be used where there is a rescue procedure to stop the fallen worker from succumbing to suspension trauma.

Further guidance on the use of IFAS is provided in the *National Code of Practice for the Prevention of Falls in General Construction*.

2.5.3 Safety nets

Safety nets can provide a satisfactory means of protection while allowing workers maximum freedom of movement.

An internal safety net can be effectively used over stairwell openings.



Safety Nets Checklist

Where it is reasonably practicable for safety nets to be used as a fall injury prevention system, employers must ensure that:

- safety nets are in position before any work is commenced
- safety nets are constructed of material of sufficient strength to catch a falling person or debris
- safety nets are installed and maintained by a licensed rigger or scaffolder
- elevating work platforms (e.g. a cherry picker or scissor lift) are used for the installation. If this is not possible, scaffolding and fall-arrest systems must be used
- safety nets are hung as close as is practicable to the underside of the working area, but no more than 2 metres below the working area
- perimeter safety nets are installed where there is no edge protection to prevent workers falling over the edges
- the safety net has sufficient tension and clearance to prevent a falling person contacting any surface or structure below the net
- no type of material is allowed to accumulate in suspended safety nets
- no welding or oxy cutting is performed above safety nets
- safety nets are not used in an environment that exposes them to damage from chemicals, sun or heat
- safety nets are inspected, particularly after installation, relocation or repair, and
- safety nets are stored correctly in dry, shaded areas with good air circulation.

2.6 LEVEL 5 CONTROLS: USE OF PORTABLE LADDERS AND ADMINISTRATIVE CONTROLS

2.6.1 Portable ladders

Portable ladders are a relatively low cost option for persons intending to undertake work at height. Their affordability combined with the ease with which they may be transported and relocated has resulted in ladders being used extensively in the housing construction industry. However, many falls take place when people are working from ladders.

Generally, ladders are only appropriate for short duration light tasks, such as painting a downpipe, repairing a gutter or carrying out minor electrical installations.

Portable ladders may be used for work carried out at 2 metres or more where other methods of working at height are not reasonably practicable.

Guidance on the use of ladders where persons are exposed to the risk of a fall of less than 2 metres is given in Part 3.2.



2.6.1.1 Selection of ladders

It is important to ensure that portable ladders are correctly selected for the task to be undertaken. In doing this, consideration should be given to the duration of the task, the physical surroundings of where the task is to be undertaken and the prevailing weather conditions. For example, metal ladders or metal reinforced ladders must not be used for live electrical work.

Ladder use for construction work typically involves repetitive use and handling, requiring ladders to be of robust design and construction. Accordingly, ladders used for construction work must be industrial grade, not domestic grade.

2.6.1.2 Safe use of ladders

Any ladder used at a workplace must be set up on a surface that is solid and stable, and set up so as to prevent the ladder from slipping. Slipping of ladders can be prevented by:

- placing single and extension ladders at a slope of 4:1, and setting up stepladders in the fully opened position, and
- securing single and extension ladders at either the top or bottom, or if necessary, at both ends (see Figure 4).

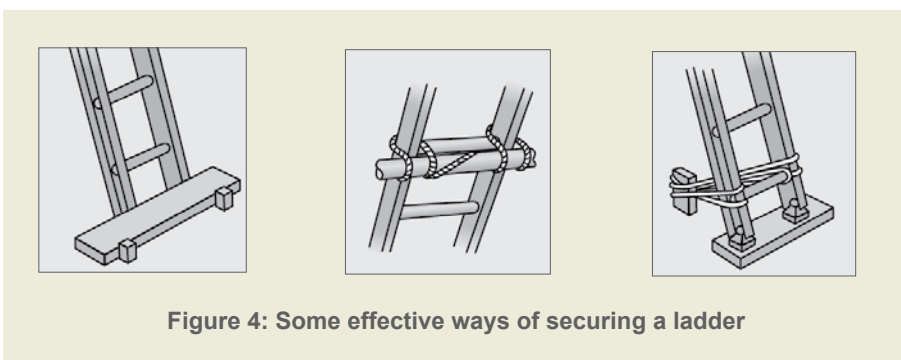

Figure 4: Some effective ways of securing a ladder

Persons using ladders must not:

- handle or use ladders where it is possible for the worker or the ladder to make contact with energised power lines, except where the person is qualified to do so
- use metal or metal reinforced ladders when working on live electrical installations
- set up the ladder in places, such as driveways and doorways, where a person or vehicle could hit it. If necessary, erect a barrier or lock the door shut
- use a stepladder near the edge of an open floor, penetration, or on scaffolding to gain extra height
- over-reach (the worker's belt buckle must be within the ladder stiles throughout the work)
- use any power (air, hydraulic, electric or battery) equipment or tool, specifically designed to be operated with two hands, such as concrete cutting saws and circular saws
- use tools which require a high degree of leverage type force which, if released, may cause the user to over balance or fall from the ladder, such as pinch bars
- carry out work such as arc welding or oxy cutting

- work over other people, or
- allow anyone else to be on the ladder at the same time.

Except where additional and appropriate fall protection equipment is used in conjunction with the ladder, any person using a ladder must not:

- face away from the ladder when going up or down, or when working from it
- stand on a rung closer than 900mm to the top of a single or extension ladder, or
- stand higher than the second tread below the top plate of any stepladder (with the exception of 3-rung step ladders).

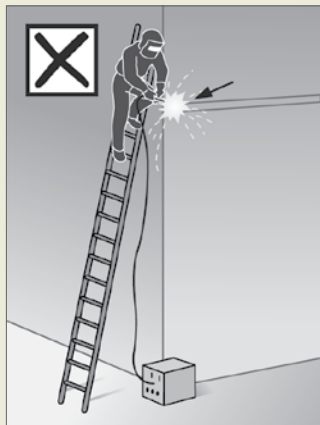

(a) Performing hot work from ladder

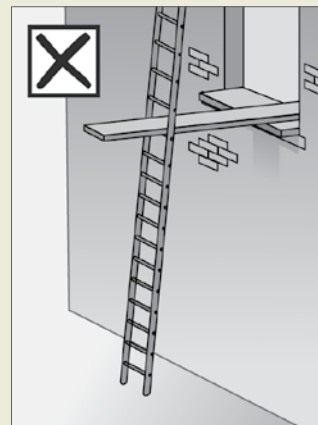

(b) Ladder set up incorrectly

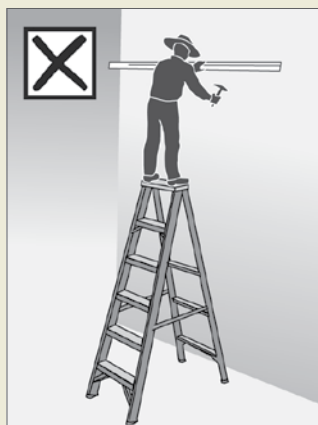

(c) Standing on top plate of stepladder

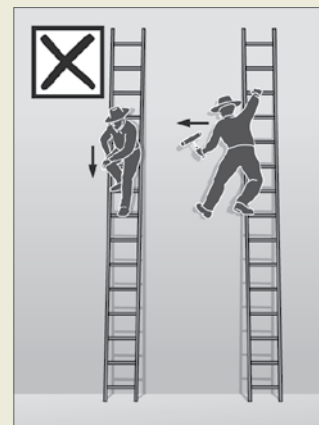

(d) Facing away from the ladder to descend; over-reaching

Figure 5: Examples of unsafe ladder use

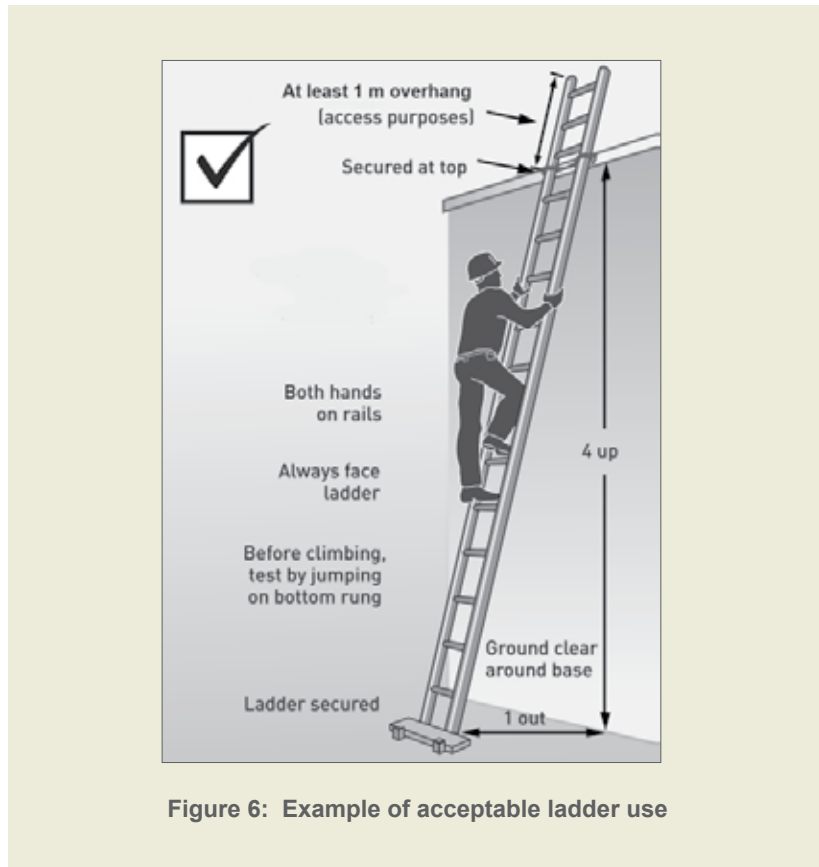

Figure 6: Example of acceptable ladder use

2.6.1.3 Ladder maintenance

Ladders should be regularly inspected by a competent person. Ladders with any of the following faults must be replaced or repaired:

- timber stiles warped, splintered, cracked or bruised
- metal stiles twisted, bent, kinked, crushed or with cracked welds or damaged feet
- rungs, steps, treads or top plates which are missing, worn, damaged or loose
- tie rods missing, broken or loose
- ropes, braces, or brackets which are missing, broken or worn, and
- timber members which are covered with opaque paint or other treatment that could disguise faults in the timber.



Ladder Checklist

If a ladder is used, check that:

- the type of ladder is appropriate to the task. Do not use 'domestic' or 'home-made' ladders. All ladders must comply with the AS/NZS 1892 series and users must follow the manufacturer's/suppliers' recommendations on safe use
- the ladder is in good condition. Before it is used, the ladder should be inspected for faults, such as broken rungs, rails and footing. Consult the manufacturer's/suppliers' checklist, if available
- damaged ladders are removed from service
- the ladder is on firm, stable and level ground
- the ladder is the correct height for the task to avoid reaching or stretching
- the ladder is not too close or too far from the support structure. The ratio must be 4:1. For example, the distance between the ladder base and the supporting structure should be about one metre for every four metres of working ladder height
- the ladder is secured against displacement (i.e. slipping or sliding) and/or there is another person holding the base of the ladder
- the ladder is not placed so that the weight of the ladder and any person using the ladder is supported by the rungs
- all the locking devices on the ladder are secure
- materials or tools are not carried while climbing the ladder. Tools should be carried in a tool belt or side pouch
- only light duty work is undertaken while on the ladder, where three points of contact can be maintained and tools can be operated safely with one hand
- slip resistant base, rungs or steps are provided
- slip resistant shoes are worn
- metal or wire bound ladders are never used close to energised power lines; non-metallic ladders must be used instead, and
- ladders are not used:
 - in access areas or next to doors;
 - on scaffolding or an elevating work platform to get extra height;
 - next to power lines;
 - in very wet or windy conditions; or
 - next to traffic areas unless the working area is barricaded.



2.6.2 Administrative controls

An administrative control is a system of work or safe work method that helps to reduce a worker's exposure to a fall hazard when it is not possible to use a higher order control. An example of this is a requirement that sheet flooring be laid by pushing it out from the centre of the building structure, rather than from the edge.

Administrative controls are often used to support other fall protection measures. Administrative controls may also be used to limit the time workers are exposed to a fall hazard and/or the number of workers involved in the task.

An administrative control should only be used as a means of reducing the risk associated with a particular task. Where it is not reasonably practicable to use a Level 1, 2, 3 or 4 control, the person with control must record the following details in the SWMS:

- a description of the administrative control used, and
- a description of the task to which the administrative control relates.

It is wise to involve workers in the development of administrative controls. People who perform a task regularly often have a good understanding of the risks involved. However, administrative controls should not be used simply because they are the lowest cost control.

2.7 SAFE WORK METHODS FOR COMMON TASKS

This section identifies common tasks in the construction of a typical one or two storey house and describes methods that eliminate or reduce the risk of falls (Figure 7) associated with these tasks. Manufacturers/suppliers instructions should be noted prior to commencing tasks. Duty holders may include these instructions in risk assessment documentation.

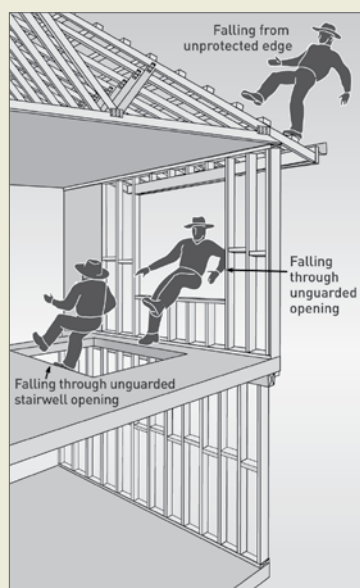

Figure 7: Potential falls in the housing construction industry



2.7.1 Floor laying

In order to construct a solid work area for the construction and/or erection of wall frames, flooring should be laid to ground and upper floors at the earliest opportunity.

Note: Working from open floor joists is an unacceptable work practice for any task.

Stairwells and voids need to be protected prior to floor laying. For further advice see Part 2.7.3.

Laying flooring is a task that potentially exposes workers to the risk of both internal and external falls. Steep sloping sites increase the potential fall heights.

The laying of floor sheets should begin adjacent to an internal or external access point which provides initial fall protection for workers. Laying of sheets should then proceed using a safe work procedure that prevents workers from falling over the edge, as shown in Figure 8 below. Where the potential fall height is 2 metres or more, edge protection must be provided. This may be external scaffolding or guardrailing as shown in Figures 9 and 10. Where strip flooring is to be installed, temporary sheet flooring may be laid and secured as fall protection.

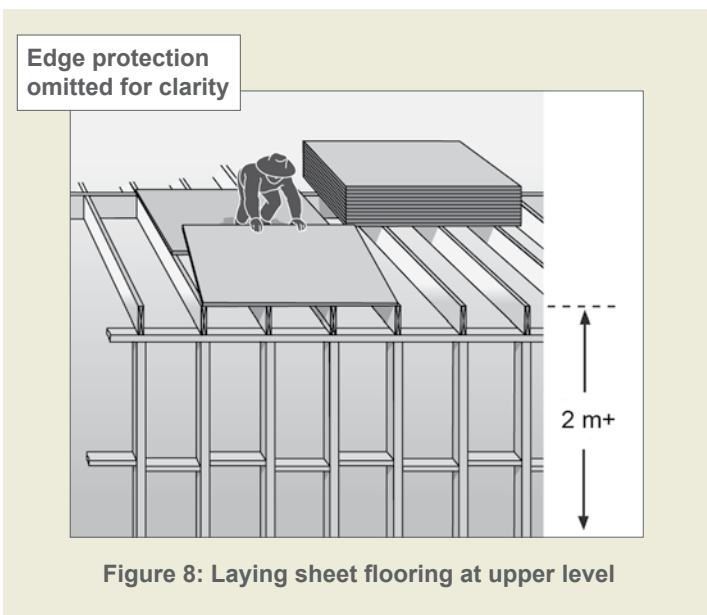

Figure 8: Laying sheet flooring at upper level

Safe access and egress must also be provided to the area where floor is being laid. Access should be restricted to only those workers who are laying the flooring and erecting the wall frames.

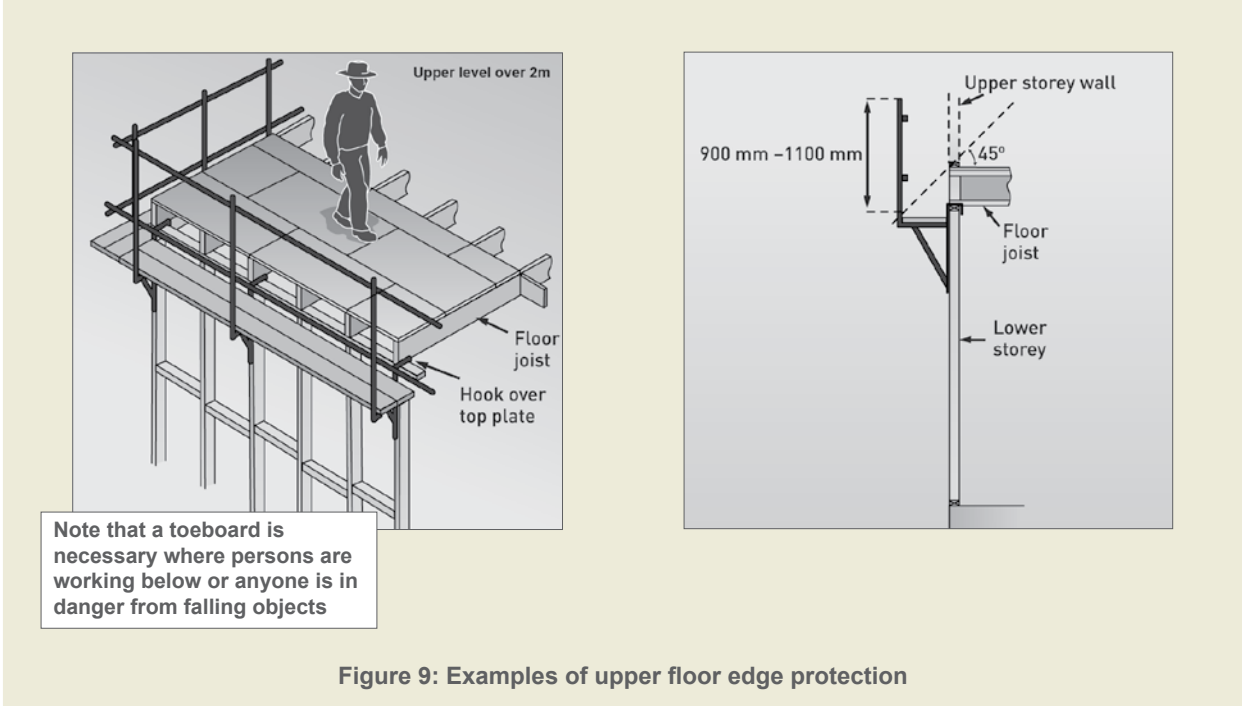

Figure 9: Examples of upper floor edge protection

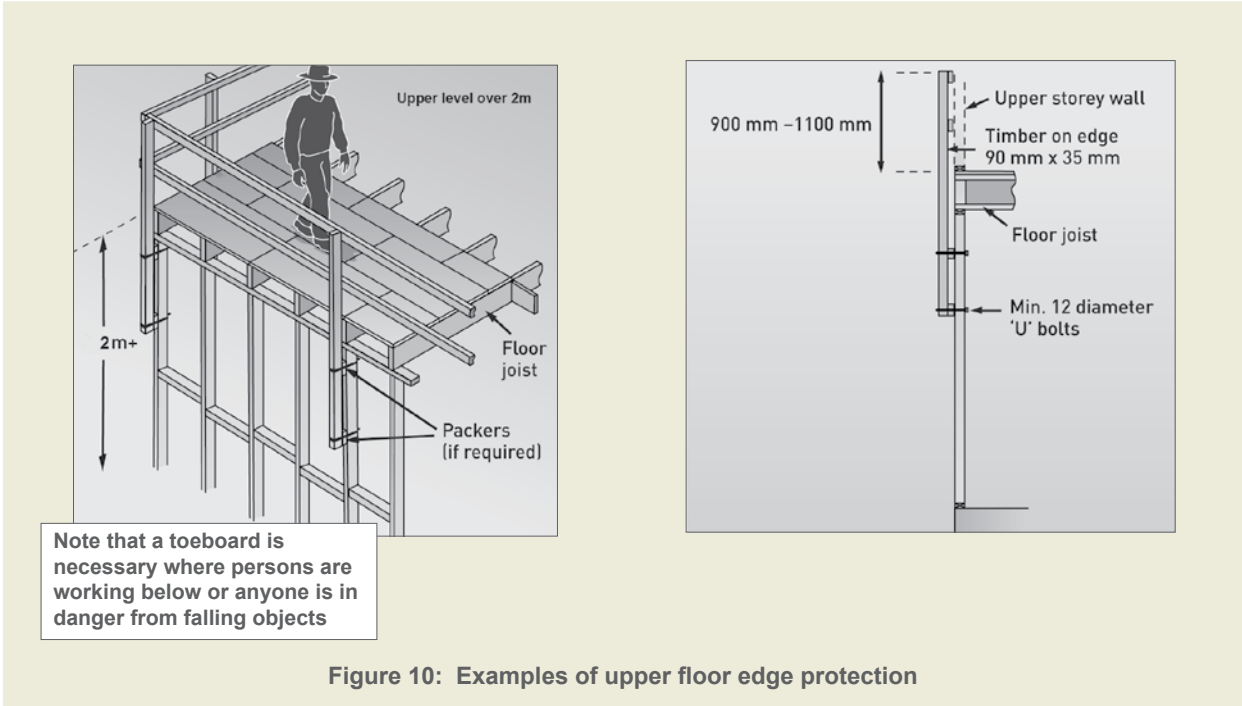

Figure 10: Examples of upper floor edge protection



2.7.2 Fixing ceiling joists and upper level floor joists

The setting out and nailing of level ceiling joists or upper level floor joists should be done by working off scaffolding set up on the floor below. Trestle scaffolds may be used as shown in Figure 11. Part 2.3.1.3 provides further information on the use of trestle scaffolds.

A person may stand on or work from the external top plate if fall protection measures are in place.

Where scaffolds are not suitable, the work may be done using ladders from the floor below.

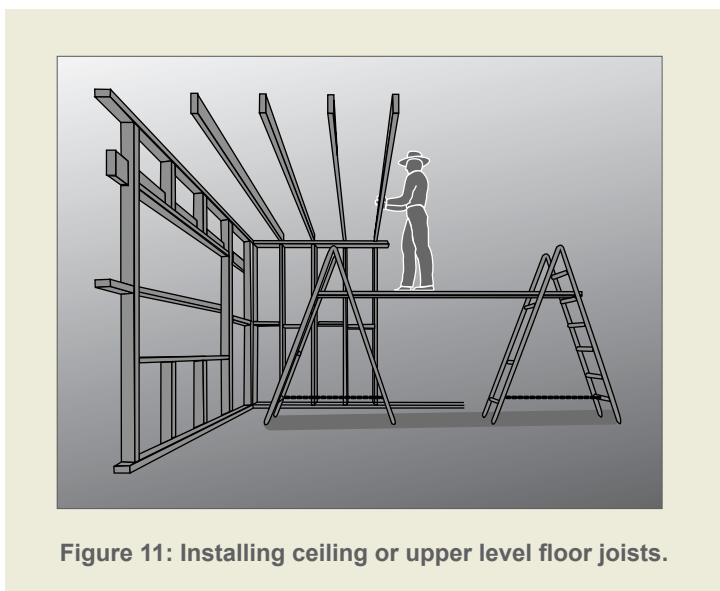

Figure 11: Installing ceiling or upper level floor joists.

2.7.3 Guarding openings

All stairwells, atriums and voids must be sturdily guarded, covered with an industrial safety net or sheeted over, regardless of the fall distance from the upper level floor. Guardrailing should be provided in accordance with Part 2.3.1.6 of this National Code. In particular, toeboards should be fitted to prevent tools and materials from being kicked into the void.

Voids and atriums must be guarded as soon as possible after laying sheet flooring, as illustrated in Figure 12.

Where a person working from a stepladder or a working platform, e.g. trestle scaffold or similar may fall over the guardrail and through the opening, the opening must be covered with temporary flooring, timber sheeting, an industrial safety net or similar, even if guardrails have been erected around it.

Any coverings or temporary floors and their supports must be of robust construction capable of withstanding impact loads from any potential falls.

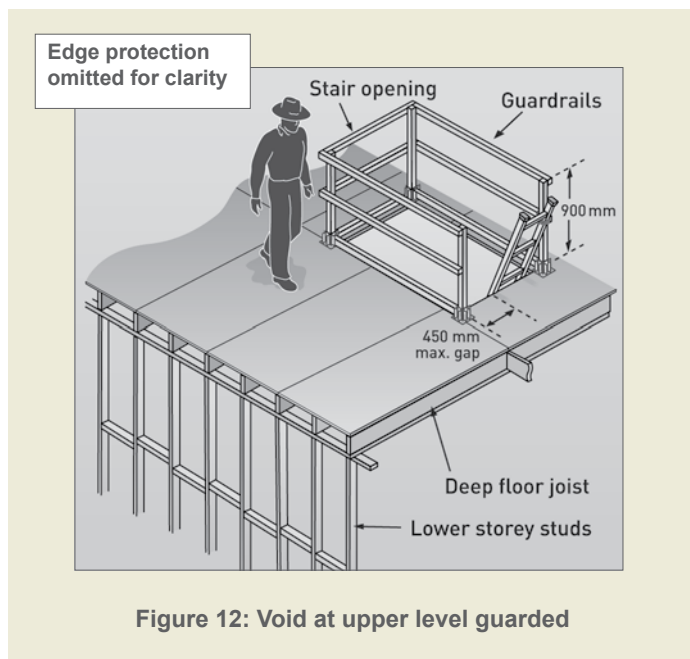

2.7.4 Wall framing

Once sheet flooring has been laid and openings have been guarded, work on wall framing may commence. Where the potential fall height for persons constructing or erecting wall frames is 2 metres or more, edge protection must be provided. Window or door openings in external wall frames must be fitted with guardrails prior to raising the frame (see Figure 13). All braces and fixings must be prepared prior to raising the frames. Access to the floor should be restricted to those workers erecting the wall frames.

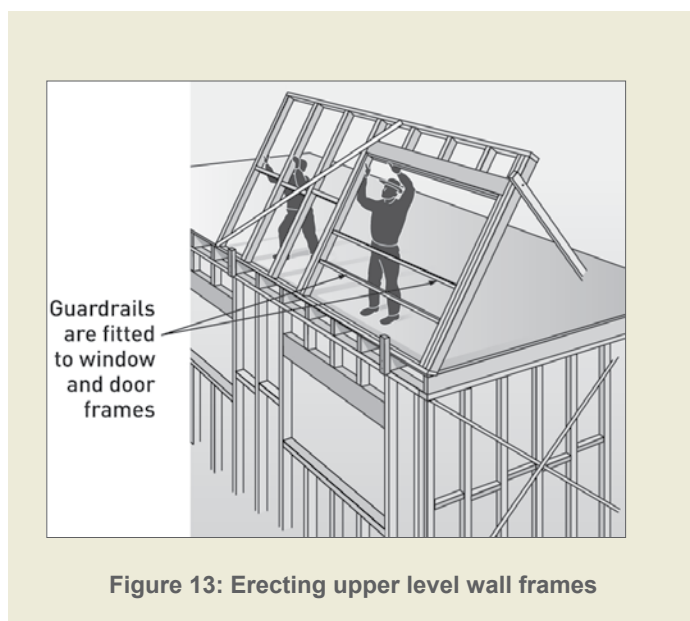



2.7.5 Installing prefabricated timber roof trusses

This section provides guidance on the installation of prefabricated timber roof trusses. Parts of this guidance may also apply to the installation of metal roof trusses.

2.7.5.1 Preparing for roof truss erection

Where practicable, roof trusses should be placed by crane on the wall top plates at the time of delivery. The truss erector, supplier and transporter should liaise to confirm the order in which the trusses are to be loaded onto the truck. Where possible, the trusses should be able to be unloaded at the site in the order that minimises the amount of handling by the truss erectors. When working at height, the erectors should be able to access the next required truss from the top of the truss stack.

Prior to commencing work ensure that all work areas have safe paths of access and egress at all times, and are free of obstructions.

When working near window penetrations and balconies, ensure all open gaps and penetrations from which a person can fall are protected. Use any of the following methods:

- first floor edge protection system
- timber railings installed at point of manufacture
- temporary stud installed by person erecting roof trusses
- guard railing system, or
- full perimeter scaffold.

It is important that relevant workers are consulted to ensure that any locations designated for the landing of trusses will not overload the wall frames. The manufacturer/supplier must provide the necessary detail and instructions for the installation of prefabricated timber roof trusses. Where trusses have not been landed directly onto the top plates, a safe system of lifting the trusses to the upper level needs to be developed. At no time must any worker stand on the top plate to receive roof trusses passed up from below.

2.7.5.2 Lifting roof trusses onto wall frame top plates for erection

The erection of roof trusses involves both internal and external fall hazards.

The erection of trusses may be undertaken from scaffold planks supported on internal wall top plates providing:

- planks are adequately supported across their spans, and
- no person is exposed to the risk of a fall into a stairwell or other void (i.e. a void protection system must be installed).

The person erecting trusses should assess the team's capability to handle the roof trusses. If the size, weight and positioning of the roof trusses pose a risk to the health and safety of the person erecting trusses, then a crane with a certificated operator must be employed to help undertake this task.



Method 1: Where cranaage is required when erection height is too great or trusses too large for manual handling:

- the trusses must be craned into position, laid flat and suitably supported prior to erection – where trusses can not be self supporting, use temporary props or internal walls for support (see Figure 14), and
- the person erecting trusses must ensure that all wall frames are adequately braced to withstand loads during construction.

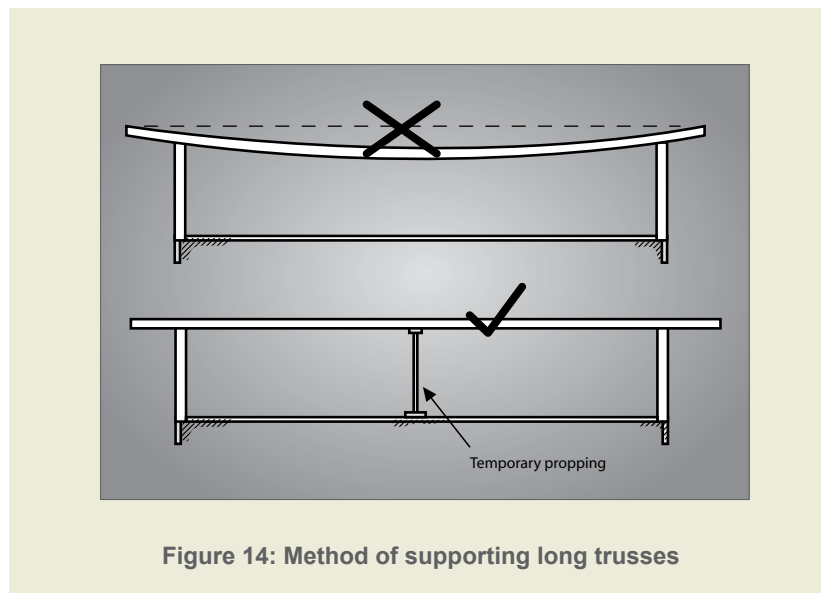

Figure 14: Method of supporting long trusses

Method 2: Where cranaage is not required:

- smaller trusses for single storey roofs can be separated from the pack and lifted individually into position along the top plates, or
- if the truss needs to be repositioned, the person erecting the trusses should do this from below to avoid working at heights.

2.7.5.3 Safe erection methods for roof trusses

At no time is any person to stand on or work from an external wall top plate without suitable fall protection.

The erection of trusses may be undertaken from internal wall top plates or from scaffold planks supported on internal wall top plates providing:

- no person works closer than 1.5 metres to an external wall, including gable end walls
- no person is exposed to the risk of a fall into a stairwell or other void
- planks are adequately supported across their spans.



Note:

- the allowable spans for timber planks are given in Table 1 of section 2.2 Appendix C
- laminated timber, aluminium and steel planks must be used in accordance with the manufacturer's directions

When trusses are erected at up to 600mm centres, persons working between the trusses to fix or brace them can use the erected trusses as a form of fall protection under controlled conditions as described below. When trusses are erected at greater than 600mm centres, refer to Part 2.7.5.4 for suggested methods of working safely at heights.

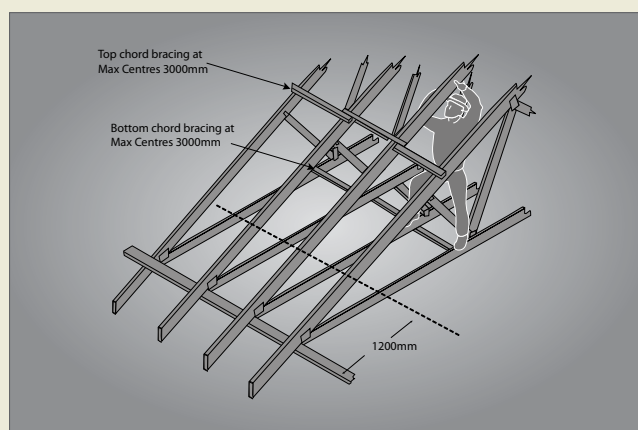

Figure 15: 'No go' zone for persons erecting trusses

Truss bottom chords are considered a safe working area for a competent person if all the conditions below are met.

If the person erecting trusses is to walk or work from the bottom chords of the trusses, the following conditions should be applied:

- trusses are adequately braced to stabilise the structure – bracing must be at a maximum of 3000mm apart if the bottom chord is used to support the person erecting trusses (see Figure 15)
- only a competent person is to work at heights
- suitable footwear that provides good foothold is to be worn
- a nominated competent person from the truss erection team is to oversee the work
- a competent person or the truss manufacturer/supplier has provided the necessary detail and instructions, including advice in regard to installers standing on the bottom chord, and
- the bottom chord is visually checked by a nominated competent person for defects that may compromise the material's structural integrity (i.e. knots, splits, cracks and rotting timber) before walking on it. If a defect is found, rectification details should be obtained from the truss manufacturer and the person with control must be notified.



If the apex or other high bracing points cannot be reached, use the following method:

- fix waling plates for standing or supporting temporary work platforms at the appropriate height to reach the apex or high points
- the waling plate should be fixed to the face of the truss according to manufacturer's recommendations to ensure the load is transferred to the bottom chord
- the waling plate should be timber of 70 x 35mm F5, or equivalent, to a maximum of 1500mm long, fixed at each end by a minimum of two 65mm x 3.15mm nails (see Figure 16)

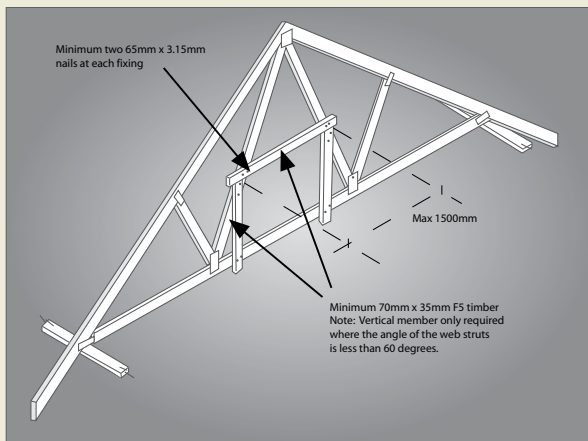

Figure 16: Suggested method of fixing temporary waling plate

- the web strut to support the waling plate should be a minimum 70 x 35mm F5, or equivalent, fixed at each end by a minimum of two 65mm x 3.15mm nails, and
- waling plates should be erected in pairs every fourth truss, or as required, to enable adequate access to fixing points for bracing (see Figure 17).

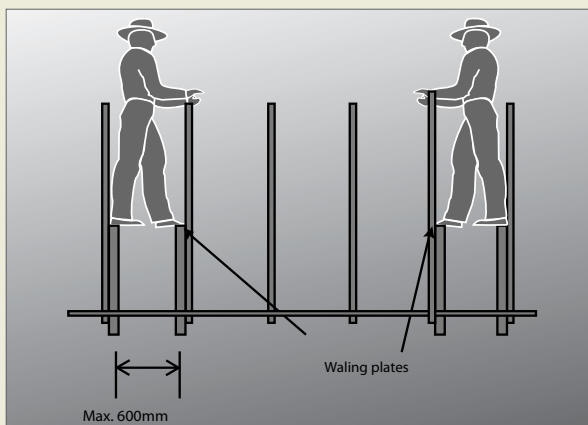

Figure 17: Showing the positions for pairs of waling plates



Erecting first and second standard trusses

Erect the first truss at the location specified by the roof manufacturer/supplier. This may be repeated a number of times for each common span series of trusses, depending on the roof layout design. Once the first and second trusses are fixed and temporarily braced in, the bottom chord may be used for the person erecting trusses to stand on or to support temporary working platforms.

Note: Where work platforms are used, they must be a minimum of 450mm wide.

The person erecting trusses should erect, fix and brace the first and second truss in the following manner:

Method 1: Cranage is used to lift and position trusses

- Set up an appropriate working platform with a platform height not greater than 2 metres from the floor level at each end where the truss is to be fixed to the top plate. Alternatively, use a ladder in accordance with Part 3.2.1. If a perimeter scaffold system is installed this work can be done from the outside rather than using internal working platforms or ladders
- Fix temporary braces to solid fixing points ready for connection to the truss. The braces can be timber of adequate size and length fixed by nails
- Guide the first truss into position while supported by the crane
- Use a minimum of two people, one at each end, to fix the truss to top plates and to the temporary braces. At this point, the first truss should be in a stable condition
- Erect the second truss using the same procedure as above, and
- Temporarily brace the second truss to the first truss.

Method 2: Cranage is not used to lift and position trusses

- Set up an appropriate working platform with a platform height not greater than 2 metres from the floor level at each end where the truss is to be fixed to the top plate. Alternatively, use a ladder in accordance with Part 3.2.1. If a perimeter scaffold system is installed this work can be done from the outside rather than using internal working platforms or ladders
- Fix temporary braces to solid fixing points ready for connection to the truss. The braces can be timber of adequate size and length fixed by nails
- Fix skid blocks to top plate at first truss position to prevent the truss from slipping during standing
- Use a minimum of two people, one at each end, to stand the first truss; a third person may be required at mid-span to assist in stabilising a long span truss with a 'v' end push stick (see Figure 18).

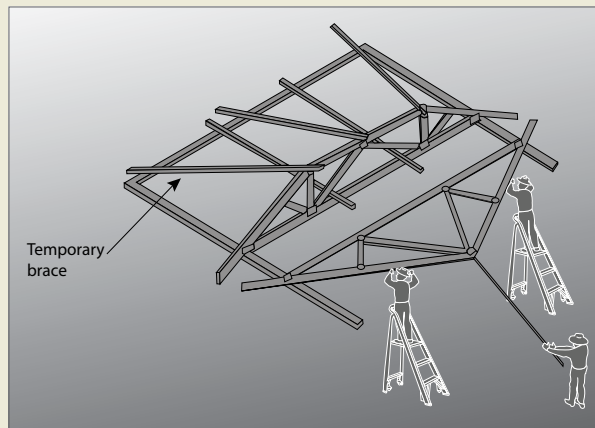

Figure 18: Recommended method of manually standing trusses with a high apex

- After standing the first truss to the vertical position, secure it to temporary braces. At this point, the first truss should be in a stable condition
- Erect the second truss using procedure above, and
- Temporarily brace the second truss to the first truss.

For both method 1 and method 2, the person erecting trusses must inspect the temporary bracing materials for obvious defects that may compromise the material's structural integrity (i.e. knots, splits, cracks and rotting timber).

Erecting subsequent roof trusses

Trusses should be taken from the stockpile and moved into position by crane or by the persons erecting them. Additional roof trusses are not to be erected unless the prescribed fixing, bracing and any additional support requirements have been undertaken for the first and second truss.

Each subsequent roof truss should be placed with each end of the truss controlled by a person on the working platform or ladder. A third person at the apex may be required to assist.

Each subsequent roof truss must be fixed and braced according to the manufacturer's/suppliers' specifications using safe methods for working at heights.

Fixing of top and bottom chord temporary bracing

Temporary ties/bracing for roof truss erection should be fixed according to AS 4440. This standard requires that temporary ties be used on the top chords at spacings no greater than 3000mm and at spacing no greater than 4000mm on the bottom chord.

If the person erecting trusses is to be supported by the bottom cords of the roof trusses, the ties/bracing must be at spacings no greater than 3000mm.



All bracing and fixing should take into consideration all imposed loads during the course of construction. As such, flat strapping or an equivalent, or trimmers nailed to the face of trusses where the nailing is from the outer face of the truss, must not be used (see Figure 19).

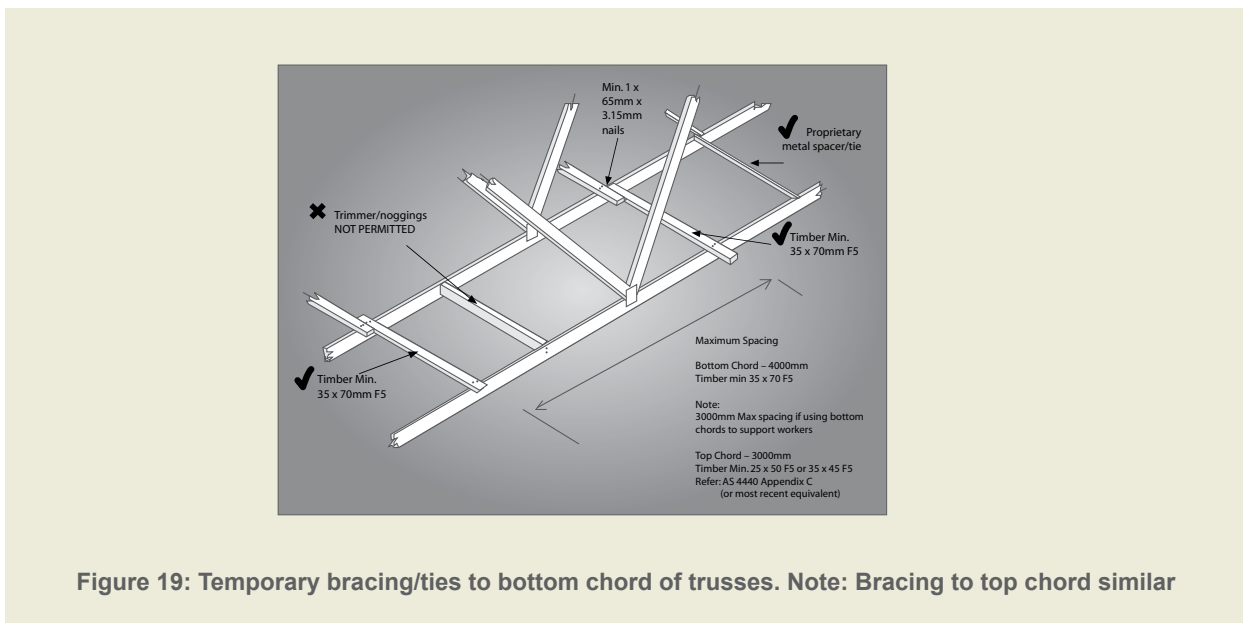

Erection of gable roof assembly and verge truss assembly (diminishing truss, verge truss, verge trimmers, gable studs/droppers)

The erection must be done using appropriate safe work methods.

Note that where reasonably practicable, elements of the roof structure, such as a verge sprocket and outriggers, should be pre-assembled on the ground as a complete unit and lifted onto the supporting structure.

Erection of ancillary items

Girder boots, hangers and the like must be installed to the manufacturer's/suppliers' specifications prior to working in the truss space.

The erection must be done using the appropriate safe work methods described in Part 2.7.7.2.

2.7.5.4 Erecting trusses at greater than 600mm centres

In certain situations, the spacing of the truss may exceed 600mm centres, in which case other fall protection must be provided when working at heights to fix and brace the trusses. Such fall protection may include:

- mobile scaffolding system complying with AS 1576 and AS 4576
- mesh or netting installed to the manufacturer's specifications
- fencing and handrails within adjacent trusses installed to the designer's or manufacturer's specifications



- working platforms, elevating platforms, including motorised single person lift platforms complying with AS 1418.10, or
- planks placed across internal and external top plates and across the bottom chords of the truss.

2.7.6 Constructing conventional or stick roof

Once the ceiling frame has been securely fixed, the ceiling frame may act as a base to install a platform. Planks or sheet flooring plywood can then be used as a platform to pitch the roof. Where additional height is required above the platform on the ceiling frame, an additional platform may be erected.

When constructing a conventional roof, ceiling joists and hanging beams can be passed up internally through a stair opening or externally through the upper level wall frame when it does not expose the receiver to further risk.

Where ceiling joists are erected prior to pitching the rafters, the placement of the ridge beam, and the fixing of rafters to it, may be done from planks or a working deck placed on the ceiling joists. Where ceiling joists are not erected, a work platform will need to be provided for framers to work from.

The practice of roof carpenters balancing on a ceiling hanger while nailing ceiling joists to the hanger is to be avoided where practicable.

Framers working at the external wall should work internally from either scaffolding or ladders or from an external perimeter scaffold. A person can work from an external top-plate if fall protection measures are in place. An external working platform will also provide a work platform for tasks such as trimming rafters and installing eaves.

Where a bracket scaffold system is used, the wall frames should be braced as necessary to ensure adequate strength and to prevent excessive deflection. Scaffold planks may be used from waling plates or across bottom chords or top plates where necessary.

Where feasible, roofing members should be pre-cut at ground level.

2.7.7 Fixing roof battens to trusses

The process for installation of the roof battens will depend on the types of roofing material that is to be installed. Although there are similarities in the methods used to install metal and tile roofing, there are also differences. Guidelines for the installation of roof battens for each type of roofing material are outlined below. For all roof work physical fall protection at the perimeter of the roof is required (see 2.3.1.6).

2.7.7.1 Batten and truss spacing

In all cases roof battens need to be capable of supporting the expected loadings from installers.

Note: For dot points 1 and 2 below, battens may be installed in a manner described in 2.7.7.2.

In addition to the external fall prevention, batten and truss spacing should be reduced to minimise the risk of internal falls:

1. Roof trusses installed and secured at spacings not exceeding 600mm centres, with batten spacings not exceeding 900mm centres, or



2. Where roof trusses are installed and secured at spacings greater than 600mm but not exceeding 900mm centres, batten spacing must not exceed 450mm centres, or
3. Where roof truss spacing exceeds 900mm centres (e.g. 1200mm) and manufacturers/suppliers instructions permit, intermediate battens must not exceed 450mm centres. They must also be installed sequentially and in a manner that controls the risk to installers, otherwise other fall protection must be used.

2.7.7.2 Installation of battens

Marking/setting out for batten positioning

If the trusses are installed at 600mm centres or less, a person may position the body so that the feet are on adjacent trusses at all times and walk to the apex of the roof in order to mark out measurements.

If trusses are at greater than 600mm centres, a person should not walk on the top chord of unbattened trusses unless internal fall protection is in place. Marking/setting out should be done sequentially throughout the batten installation process, or by working from a ladder or work platform. If this is not a viable solution, internal fall prevention options such as internal catch platforms, or the use of planks across waling plates, internal top plates and bottom chords should be used.

Installation of battens

Working off a ladder or a working platform, place the battens to be used on top of the trusses or pass/pull them up from the ground. Then secure the lower battens working from a ladder or internal or external work platform prior to roof access being required.

Secure remaining battens sequentially up to the apex of the roof by positioning the body over the truss (see Figure 20) making sure that there is at least one secured batten at waist level or above to minimise the risk of a fall.

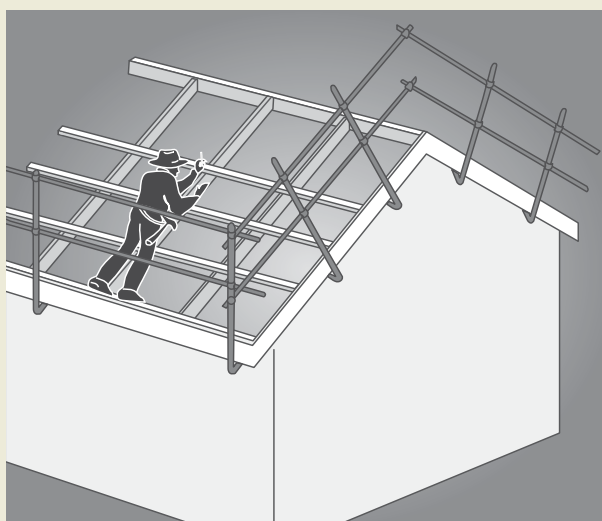

Figure 20: Fixing roof battens to trusses



2.8 ROOFING TASKS

Roofing work involves several tasks which potentially expose persons to the risk of falls both through and from the edge of the roof structure. Physical edge protection must be provided for all roofing works.

This section gives basic advice on the provision of fall protection for roofing construction work. This National Code is not intended as complete guidance where the roofing work involves dismantling or demolition work.

2.8.1 Risk controls - General

The person with control must assess and control the fall risk of persons undertaking roofing work.

2.8.2 Critical angle

The pitch of the roof is one of the key risk factors to be considered when determining the type of risk control measures to be put in place for roofing work. The critical angle is the roof pitch below which is considered that roof workers may reasonably be able to work and walk across the roof.

Builders and subcontractors should determine the critical angle as part of their risk assessment. In no case should the critical angle be taken as greater than 26 degrees or 10 degrees where the presence or likelihood of surface moisture, oil or other conditions makes the roof slippery. Consideration should be given to the fact that the critical angle may be reduced in the presence of fully glazed and wet tiles.

2.8.3 Access and egress

Suitable access must be provided for workers to access the roof to undertake works. This Code requires the access to incorporate the following as appropriate to the edge protection system being used:

- persons must be able to access the roof through the roof edge protection without having to climb over the top rail or midrail
- access ladders must be secured against movement
- where a platform is located more than 500mm below the roof edge, then additional means of access to the roof must be provided, and
- where an elevator, hoist or similar is used it must be installed so that materials can be received at the roof level.

2.8.4 Guardrail systems for roofing work

Guardrail systems must include top, mid and bottom rails or toeboards (see Figure 21). Where toeboards are used in place of bottom rails they must be able to withstand the likely impact loads.

The design and testing must comply with the relevant Australian Standards and include the following:

- toeboards or mesh infill to prevent tools, materials or debris falling from the roof, unless a 2 metre 'no go' zone has been established to prevent persons entering the area below
- a clear gap between rails not exceeding 450mm
- no gap between the roof edge, including the gutter, and a guardrail located outside the roof line exceeding 100mm
- a clear distance between the roof cladding and the bottom rail of not less than 150mm and not greater than 275mm



- an effective guardrail height above the roof surface of not less than 900mm (for roofs with a pitch over 10 degrees the effective height must be measured from a point 300mm inside the roof edge), and
- infill panels where the pitch of the roof exceeds 26 degrees.

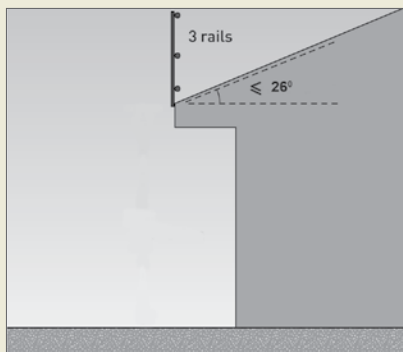

(a) Fall height greater than 2m - roof pitch at or below 26°

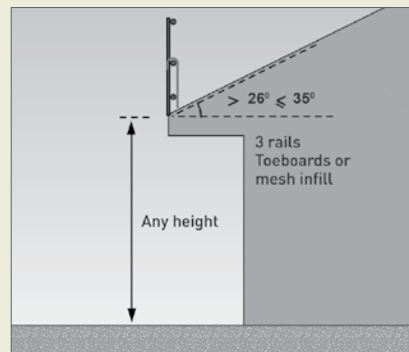

(b) Roof pitch greater than 26°

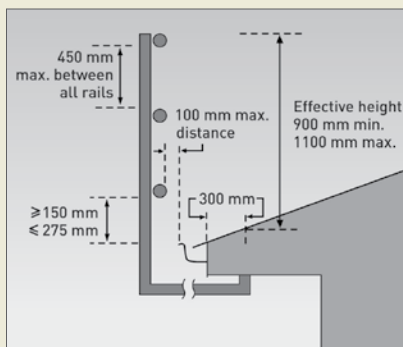

(c) Guardrail outside roof line

[Note: If gutter not present, then the 100mm maximum distance is measured from the fascia board or outer ends of the rafters or top chords to trusses]

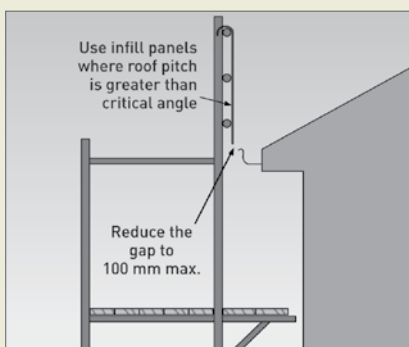

(d) Scaffolding providing guardrail protection

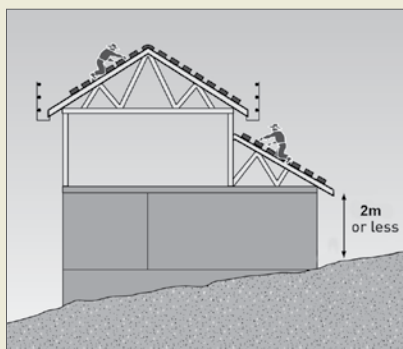

(e) Installing roofing at two levels

[Note: end guardrails omitted for clarity]

Gap between platform and gutter not more than 100mm

Figure 21: Guardrail systems for roofing work.

2.8.5 Catch platforms

Catch platforms may be constructed from many types of scaffolding systems (see Figure 22). Catch platforms used to control the risk of a fall:

- where the roof pitch is not greater than 26 degrees, should be positioned as close as feasible to the underside of the roof, and in no case greater than 1 metre below the roof edge
- where the pitch of the roof is greater than 26 degrees, should be positioned as close as feasible to the underside of the roof and in no case more than 500mm below the roof edge
- should have a guardrail, the top rail shall be located at an effective height of not less than 900mm above the point where the roofline projection intersects the guardrailing, installed with 450mm midrails
- where there is an increased risk of falling due to slippery roofing materials (such as fully glazed tiles or the presence of dust, moisture or oil on roofing) should be positioned not more than 500mm below the roof edge, regardless of roof pitch
- should incorporate a toeboard at the platform's outer edge
- should be extended to finish not more than 225mm from the building face or be fitted with edge protection on the platform's inner edge, and
- should be kept clear of equipment, materials and debris.
- For further information about the protection components refer to AS4994.

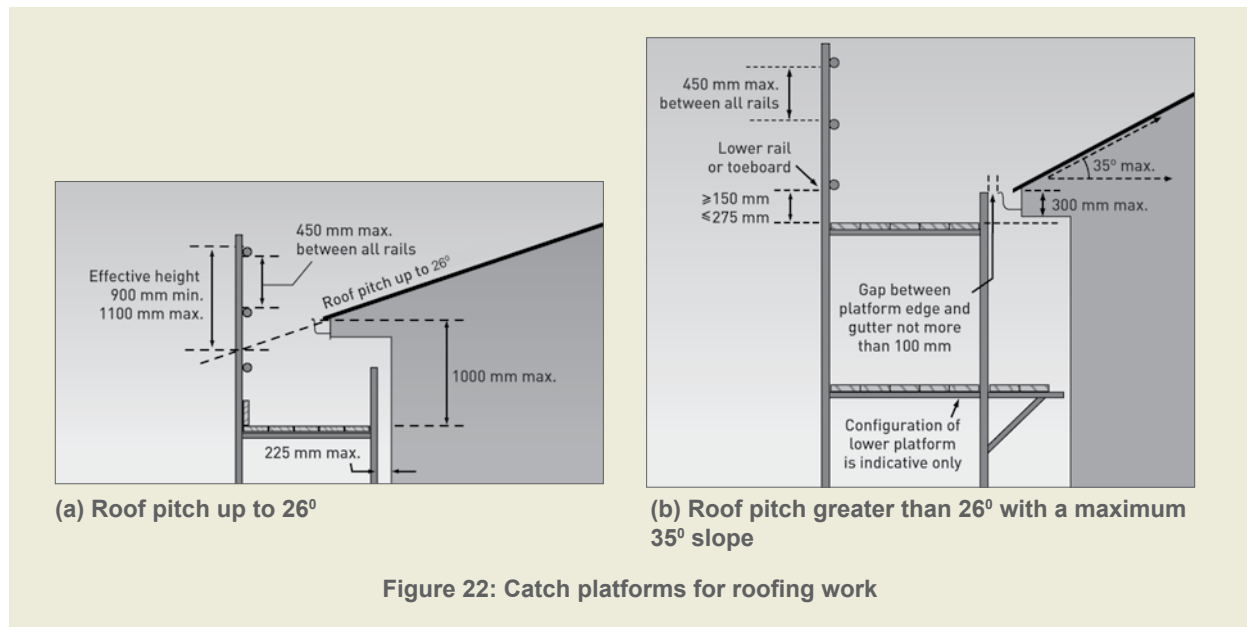

2.8.6 Steep roofs

Where the slope of a roof exceeds 35 degrees the roof is an inappropriate surface to stand on, even with guardrailing or a catch platform. In these circumstances, roof workers need a system to prevent sliding



and to prevent falls from the perimeter, comprising two or more of the following:

- a work positioning system
- a roof ladder, or
- a scaffold platform, located at the roof edge.

2.8.7 Installation of sarking – tile roofing

If sarking is used the laying of sarking should be done simultaneously with the installation of the battens. Lay the first sheet of sarking and install battens over the sheets, then lay the second sheet and install battens from the bottom of the roof to the apex.

2.8.8 Installation of perimeter battens – metal roofing

Fastening of the perimeter battens to the hips and valleys may be done by affixing those parts of the perimeter battens which can be easily reached from a position on ladders or from inside the trusses. During the sequential battening of the body of the roof, the remaining length of the perimeter battens can then be secured.

2.8.9 Fixing fascias and gutters

On houses with no eaves, fascias and gutters may be installed by working from trestle scaffolds or ladders from inside the house frame.

Where the design involves eaves, an external platform must be provided for fascia and gutter installation work. All external work platforms above 2 metres must be at least two planks (450mm) wide. Guardrailing should be fitted where the fall height is 2 metres or more, or where there are impalement hazards. If a gutter is not present, then the 100 mm maximum distance of the platform from the roof face is measured from the fascia board.

A bracket scaffold with at least two planks and guardrailing is suitable for fascia/gutter installation work (see Figure 23). The scaffold should be erected from within the structure, so that the upper level wall frame provides fall protection for the erectors. Single scaffold planks are only acceptable for work platforms where the fall height does not exceed 2 metres.

Other controls for fixing fascias and gutters may include perimeter scaffolds (for two storey construction) and elevated work platforms.

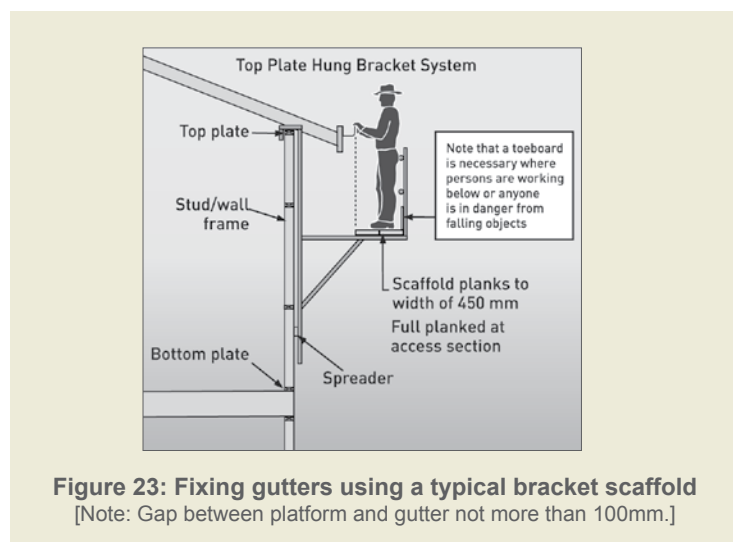



PART 3 FALLS FROM BELOW 2 METRES

A fall from almost any height can result in serious injury or death. It is possible that a number of factors can combine to create a dangerous situation. This possibility makes a hazard identification and risk assessment process very important for work at any height.

3.1 RISK ASSESSMENT

This Code requires that in situations where persons are working at heights of less than 2 metres, the standard risk assessment model of identifying fall hazards, assessing the risk of a fall occurring, and controlling the risks be adopted.

Assessing the risks of these potential falls does not need to be complicated. In most cases:

- look for the hazards
- decide who might be harmed and how
- if a risk exists, consider ways of doing the task more safely, and
- take action to eliminate the risk, or if it is not reasonably practicable to do so, then reduce the risk.

However, persons must use physical fall prevention measures and a SWMS for the work if the risk assessment identifies the need for such measures to be used.



3.2 PREVENTING FALLS OF LESS THAN 2 METRES

Some common work tasks performed at heights of less than 2 metres are illustrated below, along with solutions that prevent or reduce the risk associated with these tasks.

(a) Hazard: standing on the top plate of a stepladder

(b) A safer alternative: select the right ladder or step platform for the job

(c) Hazard: makeshift means of gaining height

(d) A safer alternative: plasterers' trestles

Figure 24: Common work tasks performed at heights of less than 2 metres



3.2.1 Portable ladders

For general advice on the selection and maintenance of ladders refer to Part 2.6.1 of this National Code.

3.2.2 Ladder bracket scaffolds

Ladder bracket scaffolds are constructed from single or extension ladders with brackets to support scaffold planks, and are to be used only for very minor tasks at heights less than 2 metres (see Figure 25). Ladder bracket scaffolds should be considered only when controls higher in the hierarchy are not reasonably practicable. Ladder bracket scaffolds are not suitable for general construction work, because the ladders and brackets are usually not capable of safely sustaining loads and the working platforms are usually narrower than the required minimum width of 450mm.

When using ladder bracket scaffolds, the following must be observed:

- only use industrial grade single or extension ladders
- pitch the ladders at a horizontal to vertical slope ratio of 1:4
- make sure the ladders are firmly footed on a hard level surface
- secure the ladders against movement in any direction
- keep the horizontal distance between brackets to 2.4 metres or less
- make sure the planks are genuine scaffold planks in good condition and secured against sliding
- never place a working platform at a height where a person could fall more than 2 metres
- provide barricades or other suitable controls to prevent traffic damage
- no more than one person should be supported in any bay of the scaffold, and
- do not stack materials on the working platform.

For further information refer to AS 4576.

Where reasonably practicable ladder bracket scaffolds should have clear access to and egress from ladders at each landing.

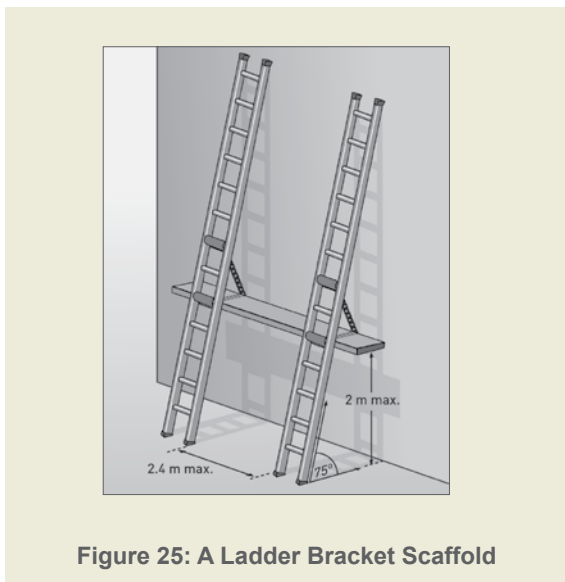

Figure 25: A Ladder Bracket Scaffold



4. DEFINITIONS

For the purpose of this Code:

‘Administrative control’ is a system of work or safe work method that helps to reduce a worker’s exposure to a fall hazard. Administrative controls are often used to support other fall prevention measures.

‘Anchorage’ means a secure point for attaching a lanyard, lifeline or other component of a travel restraint system or fall-arrest system. Anchorages require specific load and impact capacities for their intended use.

‘Australian Standard’, ‘Australian/New Zealand Standard’, ‘AS’ and ‘AS/NZS’ refer to standards developed and published by Standards Australia International.

‘Client’ means any person who commissions design work for a structure.

‘Design’ in relation to any structure means any drawing, design detail, scope of works document or specification relating to the structure.

‘Designer’ means a person whose profession, trade or business involves them in:

- preparing designs for structures, including variations to a plan or changes to a structure, or
- arranging for people under their control to prepare designs for structures.

‘Elevating work platform’ (EWP) means a telescoping, scissor or articulating device, or any combination of these, that is used to position personnel, material or equipment at an elevated work area.

‘Formwork’ means the surface, supports and framing used to define the shape of concrete until the concrete is self-supporting. It includes the forms on which the concrete is poured, the supports used to withstand the loads imposed by the forms and the concrete, the bracing that may be added to ensure stability, and the footings. The formwork structure is called the formwork assembly. Parts of the formwork assembly are also known as falsework. Examples of formwork include prefabricated systems such as slip forms, table forms and jump forms.

‘Guardrailing’ is a protective barrier attached directly to a house, building, scaffold or other structure by posts.

‘Hazard’ is, with regard to falls from a height, any situation where there is potential for someone to fall from one level to another.

‘Individual fall-arrest system’ is a system designed to arrest a fall.

‘Industrial rope access system’ means a work positioning system used for gaining access to and working at a work face, usually by means of vertically suspended ropes.

‘Inertia reel’ (also known as a self-retracting lanyard or fall-arrest block) — is a mechanical device that arrests a fall by locking onto a dropline and at the same time allows freedom of movement.

‘Lanyard’ means a line used, usually as part of a lanyard assembly, to connect a harness to an anchorage point or static line.

‘Lanyard assembly’ means an assembly consisting of a lanyard and a personal energy absorber. The lanyard assembly should be as short as reasonably practicable, with a working length of not more than 2 metres.



‘Licensed’ means the person holds relevant qualification from an appropriate body.

‘Likelihood’ means the probability that an event will occur.

‘National Standard for Construction Work’ or **‘National Standard’** means the *National Standard for Construction Work [NOHSC: 1016(2005)]*, declared by the National Occupational Health and Safety Commission, and as amended.

‘National Code’ refers to the *National Code of Practice for the Prevention of Falls in Housing Construction*.

‘Passive fall prevention device’ means material or equipment, or a combination of material and equipment, that is designed to prevent a person from falling, and which, after initial installation, requires ongoing inspections to ensure its integrity but does not require ongoing adjustment, alteration or operation to perform its function. Examples include scaffolding and perimeter guardrailing.

‘Person with control of a construction project’ can include people such as principal, head or main contractors, builders, employers or persons with management control.

‘Person with control of construction work’ can include principal, main and subcontractors, employers and self-employed persons.

‘Person with control’ means:

- a person with control over the workplace, or
- a person with control over work.

‘Person with control over a workplace’ means a person who has management or control of a workplace.

Note: An owner of a workplace and an occupier of a workplace can be persons with control of workplaces, to the extent that they have management or control of the workplace. An employer may also be the owner or occupier of a workplace.

‘Person with control of work’ means a person who has management or control over work.

Note: An employer, owner, manager of a labour hire company, franchisee and franchisor, will be a person with control of work and a self-employed person, such as a sub-contractor, can be persons with control of work. Each is considered a person with control of work to the extent that they have management or control of the work.

‘Principal contractor’

1. The owner is the principal contractor of the workplace where the construction project is to be carried out unless the owner—
 - a. appoints a principal contractor for the construction work performed for or on behalf of the owner; and
 - b. authorises the principal contractor to manage or control the workplace to the extent necessary to discharge the duties imposed on a principal contractor under this Subdivision.

- 
2. If domestic premises become a workplace due to construction work being performed and the owner of those premises engages a person to manage or control the workplace, the person engaged is taken to be the principal contractor for the purposes of this National Code.

‘Reasonably practicable’ means what can be done and which is reasonable in the circumstances taking account of:

- the probability (likelihood) of the hazard or risk occurring
- the degree of harm arising from the hazard or risk
- the availability and suitability of ways to remove or mitigate the hazard or risk
- the state of knowledge about the hazard or risk and ways it may be removed or mitigated, and
- the cost of removing or mitigating the hazard or risk.

‘Risk’ means the likelihood of a hazard causing harm to a person.

‘Safe Work Method Statement’ (SWMS) means a statement that:

- identifies a work activity assessed as having a safety risk or risks
- states the safety risk or risks
- describes the control measures that will be applied to the work activity
- describes how safety measures will be implemented, and
- includes a description of the equipment used in the work, the qualifications of the personnel doing the work and the training required to do the work safely.

‘Scaffold’ is a temporary structure specifically erected to support one or more access platforms or working platforms.

‘Solid construction’ means a constructed supporting surface that:

- is structurally capable of supporting people, material and any other loads intended to be applied to it
- is provided with protection at its perimeter, around open penetrations and around any other area
- necessary to prevent persons from falling
- has an even and readily negotiable surface and gradient, and
- is provided with a safe means of access and egress.

‘Structure’ means:

- any building, steel or reinforced concrete construction, railway line or siding, tramway line, dock, ship, submarine, harbour, inland navigation channel, tunnel, shaft, bridge, viaduct, waterworks, reservoir, pipe or pipeline (whatever it contains or is intended to contain), structural cable, aqueduct, sewer, sewerage works, gasholder, road, airfield, sea defence works, river works, drainage works, earthworks, constructed lagoon, dam, wall, mast, tower, pylon, underground tank, earth retaining construction, fixed plant, construction designed to preserve or alter any natural feature, and any other similar construction, and
- any formwork, falsework, scaffold or other construction designed or used to provide support or access during construction work.



'Travel restraint system' means a system in which a harness or belt is attached to one or more lanyards, each attached in turn to a static line or anchorage point, so as to restrict the travelling range of a person wearing the harness or belt and preventing them from reaching a position from which they could fall.

'Work positioning system' means any equipment, other than a temporary work platform, which enables a person to be positioned and safely supported at a work location for the duration of that work.

APPENDIX A REFERENCED DOCUMENTS AND FURTHER READING

Word content and illustrations in this document are based on the WorkSafe Victoria publication titled *Code of Practice – Prevention of Falls in Housing Construction* (No. 29, 31 March 2004). The WorkSafe Victoria website (www.worksafe.vic.gov.au) should be accessed for further information and future updates on the references used.

Word content and illustrations in Part 2.7.5 *Installing prefabricated roof trusses* has been sourced from the WorkCover Authority of NSW publication titled *Erection of Timber Roof Trusses Industry Safety Standard April 2007*.

Checklists in this document are based on checklists found in the Government of Western Australia publication titled *Code of Practice – Prevention of Falls at Workplaces 2004*.

Australian Standards

(At the time of publication, the Australian Standards referenced in this appendix are current. Users of this document should ensure that the referenced standard has not been updated or replaced.)

AS 1418.10	Cranes, hoists and winches – Elevating work platforms
AS/NZS 1576 series	Scaffolding
AS 1577	Scaffold planks
AS 1657	Fixed platforms, walkways, stairways and ladders – Design, construction and installation
AS 1720.1	Timber structures - Design methods
AS/NZS 1891.1	Industrial fall-arrest systems and devices – Harnesses and ancillary equipment
AS/NZS 1891.3	Industrial fall-arrest systems and devices – Fall-arrest devices
AS/NZS 1891.4	Industrial fall-arrest systems and devices – Selection, use and maintenance
AS/NZS 1892 series	Portable ladders
AS 2550.1	Cranes, hoists and winches – Safe use – General requirements
AS 2550.10	Cranes, hoists and winches – Safe use – Mobile elevating work platforms



Australian Standards

(At the time of publication, the Australian Standards referenced in this appendix are current. Users of this document should ensure that the referenced standard has not been updated or replaced.)

AS 2626	Industrial safety belts and harnesses – Selection, use and maintenance
AS 3566.1	Self-drilling screws for the building and construction industries - General requirements and mechanical properties
AS 3623	Domestic metal framing
AS/NZS 4389	Safety mesh
AS 4440	Installation of nailplated timber roof trusses
AS/NZS 4488 series	Industrial rope access systems
AS/NZS 4576	Guidelines for scaffolding
AS/NZS 4994.1	Temporary roof edge protection for housing and residential buildings - General requirements
AS/NZS 4994.2	Temporary roof edge protection for housing and residential buildings - Installation and dismantling

Other

Building Code of Australia, published by the Australian Building Codes Board

APPENDIX B OHS AUTHORITIES

AUSTRALIAN GOVERNMENT

Comcare

Level 4 (Reception)
14 Moore Street
CANBERRA ACT 2600
GPO Box 9905
CANBERRA ACT 2601
Switch: (02) 6275 0000
Workers' Comp: 1300 366 979
OHS Hotline: 1800 642 770
ohs.help@comcare.gov.au
Media Enquiries: 1300 366 979
Fax: (02) 6248 0322
www.comcare.gov.au

STATE & TERRITORY GOVERNMENT OHS AGENCIES

New South Wales

WorkCover Authority of NSW
92-100 Donnison Street
GOSFORD NSW 2250
Switch: (02) 4321 5000
Information Centre: 13 10 50
Fax: (02) 4325 4145
www.workcover.nsw.gov.au
Construction Hotline (24 hours): (02) 8260 5881

Western Australia

WorkSafe Western Australia
5th Floor, WestCentre,
1260 Hay Street
West Perth WA 6005
Reception: (08) 9327 8800
Fax: (08) 9321 8973
Toll Free Enquiries Line: 1300 307 877
Accident Notification Line: 1800 678 198
safety@commerce.wa.gov.au
www.worksafe.wa.gov.au

Victoria

Victorian WorkCover Authority
222 Exhibition Street
MELBOURNE VIC 3000
Switch: (03) 9641 1555
Advisory: 1800 136 089 (VIC only)
Advisory: (03) 9641 1444
Fax: (03) 9641 1222
www.workcover.vic.gov.au

South Australia

SafeWork SA
GPO Box 465
ADELAIDE, SA 5001
Switch: (08) 8303 0400
Fax: (08) 8303 0277
Help and Early Intervention Centre: 1300 365 255
www.safework.sa.gov.au

Tasmania

Workplace Standards Tasmania
Department of Justice
PO Box 56
ROSNY PARK TAS 7018
Switch: (03) 6233 7657
1300 366 322 (TAS only)
Fax: (03) 6233 8338
www.wst.tas.gov.au

Queensland

Workplace Health & Safety
Department of Employment & Industrial Relations
GPO Box 69
BRISBANE QLD 4001
Information: 1300 369 915
Switch: (07) 3225 2000 (outside Qld.)
Fax: (07) 3225 1540
www.deir.qld.gov.au/workplace/index.htm



Australian Capital Territory

ACT WorkCover
GPO Box 158
CANBERRA CITY ACT 2601

Switch: (02) 6207 3000 or (02) 6205 0200

Fax: (02) 6205 0336

www.workcover.act.gov.au

Northern Territory

NT WorkSafe
GPO Box 1722
DARWIN NT 0801

Switch: (08) 8999 5010

1800 019 115 (NT only)

Fax: (08) 8999 5141

www.worksafe.nt.gov.au



APPENDIX C TIMBER SCAFFOLDS

SECTION 1 - INTRODUCTION

1.1 SCOPE

This appendix sets out recommended rules for the construction of timber scaffolds for works carried out in connection with buildings or structures as defined in Part 1.3 of this National Code, and where the vertical distance between the working platform and the lowest level to which a person or object could fall does not exceed 6 metres, and where the scaffold supports no more than one full-length working platform².

1.2 GENERAL

All scaffolds must be designed and constructed in accordance with AS/NZS 1576.1. Scaffolds which are constructed in accordance with Section 2 or Section 3 of this appendix are deemed to comply with AS/NZS 1576.1.

Where it is intended to construct any timber scaffold which:

- a. does not comply with Section 2 or Section 3, and
- b. has a working platform greater than 2 metres above the lowest level to which a person or object may fall

the person with control must ensure that a copy of the detailed design drawings for the scaffold, prepared by a competent person, is kept on site.

SECTION 2 - TIMBER SCAFFOLDS - MAXIMUM 2 METRE LIFT HEIGHTS

2.1 SCAFFOLD COMPONENTS

Load bearing structural members used or intended to be used in the construction of a timber scaffold in accordance with this part, including standards, ledgers, guardrails, midrails, putlogs, braces, ties and rakers, shall have a stress grading of not less than:

- a. F8 unseasoned hardwood, or
- b. MGP 12 seasoned pine.

² Short working platforms may be set up in different positions on a scaffold provided that not more than one working platform is set up or used in any one bay.



The minimum cross-sectional dimensions of structural members shall be as specified in Sections 2.4 to 2.9. The timber sizes listed in this section are the nominal sizes for rough sawn timber. Where this appendix nominates an alternative use of a higher grade seasoned dressed timber, the equivalent dressed size may be used.

All components intended for use in the construction of a timber scaffold must be visually inspected for defects prior to each use and components found to be in an unserviceable condition must not be used.

2.2 WORKING PLATFORM

Working platforms supported by timber scaffolds should be classified as:

- light duty, for loads (persons and materials) of up to 225 kg per bay, or
- medium duty, for loads (persons and materials) of up to 450 kg per bay, or
- heavy duty, for loads (persons and materials) of up to 675 kg per bay.

The minimum width and length of working platforms shall be:

- 450mm for light duty working platforms
- 900mm for medium duty working platforms, and
- 1000mm for heavy duty working platforms.

Planks used or intended to be used in the construction of working platforms shall be random planks³ complying with AS 1577. The maximum spans of solid timber scaffold planks complying with AS 1577 are given in Table 1.

Scaffold planks forming a working platform shall:

- be of uniform thickness to prevent trip hazards
- be closely laid across the full width of the scaffold to prevent traps and to prevent material or debris from falling through gaps
- extend beyond their end putlogs not less than 150mm nor more than 250mm
- be supported by putlogs at spacings not greater than the maximum spacing marked on the plank⁴
- except at returns or on unusually shaped profiles, be butted rather than lapped, and
- where necessary, be adequately secured against uplift or displacement.

³ 'Random plank' is defined in AS 1577, Scaffold planks, as 'a scaffold plank of any length which is designed and intended to be simply supported by putlogs and to overhang its end supports'.

⁴ Random scaffold planks manufactured prior to 1993 may not have their maximum allowable span marked on them. In such cases, putlog spacings shall not be greater than 1.5 m for 38 mm thickness scaffold planks, 2.0 m for 50 mm thickness scaffold planks or 2.5 m for 63 mm thickness scaffold planks.



Nominal thickness of plank (mm)	Maximum span between trestles (m)
32 (hardwood only)	1.0
38	1.5
50	2.0
63	2.5

Table 1 - Maximum span of solid timber scaffold planks complying with AS 1577

2.3 FIXINGS

Any reference to the use of screws in this section means the use of 10 gauge self-drilling screws complying with AS 3566. Screws must be long enough to have a minimum embedment length of 35mm into the supporting member.

Fixing for ledgers shall be not less than:

- one 12mm diameter mild steel bolt, nut and washer, or
- where the ledger rests on blocking, a 10mm mild steel bolt, nut and washer. The blocking must be a minimum 200mm long of the same cross sectional area as the ledger and secured by a minimum of two screws to the standard.

Guardrails, midrails, braces and ties shall be fixed with a minimum of two screws.

2.4 STANDARDS

Standards shall be vertical and shall be pitched on timber soleplates of sufficient area to distribute imposed loads without observable subsidence.

There shall be no cavity under a soleplate immediately below a standard.

Where the height of the scaffold requires joints in the standards, they shall be staggered and must not occur:

- in adjacent standards in the same lift
- in the same standard in adjacent lifts
- more than once between adjacent ledgers, or
- more than 300mm from a ledger.

Joints in standards should be butted and spliced.

The minimum cross-sectional dimensions of standards and the maximum longitudinal and transverse spacing of standards are set out in Table 2.



Standards

Minimum nominal size (mm)	Duty classification of working platform	Maximum centre-to-centre longitudinal spacing	Maximum centre-to-centre transverse spacing
75 x 38	Light duty	1.2m	660mm
100 x 38	Light duty	2.4m	1.2m
100 x 50	Medium duty	2.4m	1.2m
100 x 75	Heavy duty	2.4m	1.2m

Table 2 - Standards

2.5 LEDGERS

Each longitudinal row of standards shall be joined on the inside face with horizontal ledgers, with their greater cross-sectional dimension vertical, extending the full length of the scaffold.

The distance between the surface supporting a standard and the first ledger and the distance between vertically adjacent standards shall not exceed 2 metres.

The minimum cross-sectional dimensions of ledgers are set out in Table 3.

Joints in ledgers shall be butted and spliced. The joints shall be staggered and should not occur:

- in horizontally adjacent ledgers in the same bay
- in vertically adjacent ledgers in the same bay
- in the same ledger in the same bay
- in the end bays of a scaffold, or
- more than 300mm from a standard.

Ledgers

Minimum nominal sizes (mm)	Duty classification of working platform
75 x 38	Light duty
100 x 50	Medium duty
100 x 75	Heavy duty

Table 3 - Ledgers

2.6 PUTLOGS



The scaffold shall be fixed in the transverse plane at each lift with putlogs.

Putlogs shall be set above ledgers with their greater cross-sectional dimension vertical and shall be securely fixed to the ledgers or standards.

Putlogs shall be nailed to the upper surface of the ledger to secure them against dislodgement.

At each end of the scaffold, a putlog shall be fixed at a distance not greater than 200mm from the edge of the standard.

Where the scaffold is two or more bays in length, a pair of putlogs shall be fixed, one on either side of the intermediate standards, with the putlog spacing being not greater than 500mm.

Where the planks of a working platform butt away from the standards, additional putlogs may be required. In any case, the overhang of planks shall not be less than 150mm and not more than 250mm.

In the case of a single pole scaffold, the inside end of each putlog shall be fixed to the house frame by a minimum of two screws and shall also be seated on minimum 300mm long timber blocks of the same cross-section, fixed to the frame studs with a minimum of two nails. No joint shall occur in the length of a putlog.

The cross-sectional dimensions and the maximum span of putlogs are set out in Table 4.

Putlogs

Minimum sizes (mm)	Duty classification of working platform	Maximum centre to centre span
75 x 38	Light duty	660mm
100 x 50	Medium duty	1.2m
125 x 50	Heavy duty	1.2m

Table 4 - Putlogs

2.7 BRACING

Transverse braces must be fixed diagonally in each lift at each end of the scaffold.

Longitudinal braces shall be fixed in each lift of the scaffold to the outside of the outer row of standards, with the distance between braced bays not exceeding three bays in length.

Braces shall be fixed diagonally as close as possible to the intersection of the standards and ledgers and, in the first lift, the lower end of a brace shall be fixed as close as possible to the intersection of the standard and its soleplate.

In the case of a single pole scaffold, the inside end of a transverse brace shall be fixed as close as possible to the intersection of a putlog and the building or structure.

Braces shall be a minimum of F8 unseasoned hardwood or MGP 12 seasoned pine with cross-sectional dimensions not less than:

- 
- 75mm x 38mm for a scaffold supporting a light duty working platform, and
 - 100mm x 50mm for a scaffold supporting a medium duty or heavy duty working platform.

2.8 STABILITY

Every scaffold must be effectively stabilised by tying to the building or an adjacent structure, or by rakers to the ground.

Ties and rakers shall comply with the following:

- except in single pole scaffolds, ties shall be fixed to both standards
- where rakers are used, they shall be of the same material as the standards, fixed to the outer standards and, at ground level, they shall be firmly footed or fixed with timber stakes driven into the ground, and they must be positioned at approximately 45 degrees to the horizontal
- the first level of ties or rakers shall not be higher than 4 metres above the lowest soleplate
- the distance between longitudinally adjacent ties or rakers shall not exceed two bays
- ties shall not be fixed to the cladding of a building or structure
- ties and rakers shall be positioned so as not to obstruct access along the working platform
- no more than one lift shall be constructed above the highest level of ties or rakers
- the minimum cross-sectional dimensions of ties shall be the same as for braces, and
- ties and rakers shall be continuous in their length.

2.9 SPLICING OF MEMBERS

Where members are spliced, such joints shall be butt joints with fishplates of the same cross-sectional dimensions fixed equidistant on each side of the butt point, and bolted through with four 12mm diameter mild steel bolts, washers and nuts, spaced at 225mm centres.

2.10 WORKING PLATFORM EDGE PROTECTION AND ACCESS

Working platforms shall be provided with edge protection and with safe means of access and egress in accordance with AS/NZS 4576. Part 2.3.1.6 of this National Code also provides guidance on guardrailing.

SECTION 3 - TIMBER SCAFFOLDS – SINGLE POLE WITH HIGH FIRST LIFT HEIGHT.

This section provides deemed to comply advice for single pole scaffolds with:

- a first lift height of up to 6 metres, and
- a maximum load rating of medium duty

These scaffolds are typically suitable for many work tasks in the construction of double storey extensions, including the fixing of cladding, general carpentry, rendering and painting. Scaffolds

prescribed in this section are not suitable for heavy duty works such as bricklaying.

3.1 CONFIGURATION

The configuration of scaffolds prescribed in this section shall be as shown in Figure 26.

For scaffolds erected in accordance with this section the primary loads are transferred directly from the working platform to the putlogs at each standard. These putlogs transfer the loads directly to the standard at the outer face and to the building frame at the inner face. Intermediate putlogs, supported by a ledger, are only required where it is necessary, to ensure planks do not exceed their allowable span or where planks are butted along the working platform.

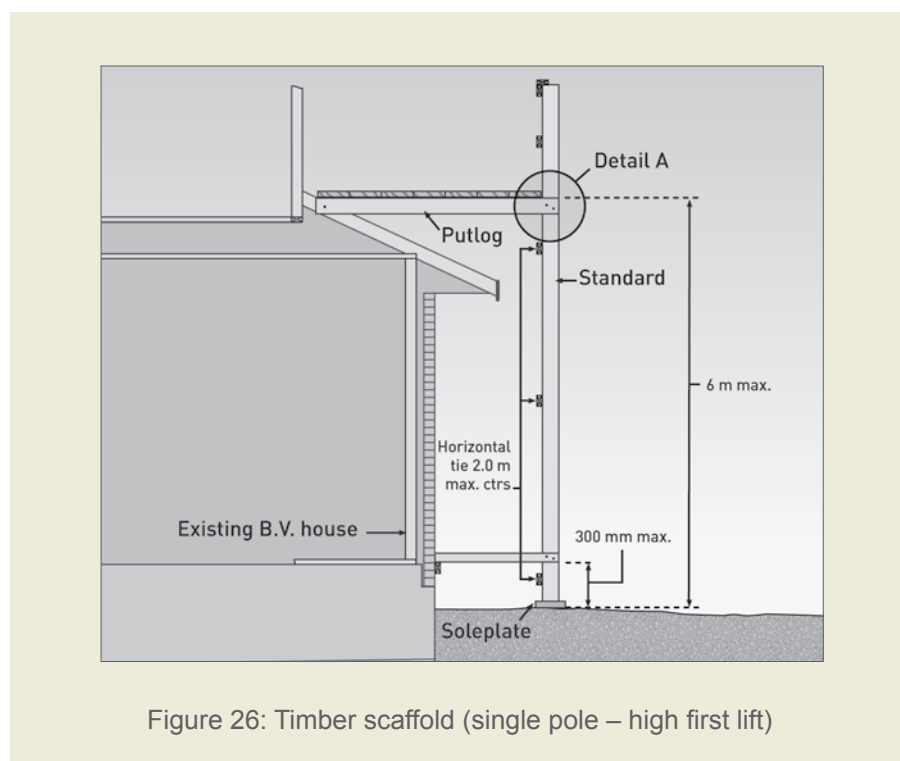

Figure 26: Timber scaffold (single pole – high first lift)

3.2 SCAFFOLD COMPONENTS

Load bearing structural members used or intended to be used in the construction of a timber scaffold in accordance with this section, including standards, guardrails, midrails, putlogs, braces, ties and rakers, shall have dimensions and stress gradings as specified in Sections 3.5 to 3.9.

All components intended for use in the construction of a timber scaffold shall be visually inspected for defects prior to each use and components found to be in an unserviceable condition shall not be used.

3.3 WORKING PLATFORM



Working platforms supported by timber scaffolds constructed in accordance with this section shall comply with Section 2.2 and shall be classified as:

- light duty, for loads (persons and materials) of up to 225kg per bay, or
- medium duty, for loads (persons and materials) of up to 450kg per bay.

3.4 FIXINGS

Any reference to the use of screws in this section means the use of Type 17 self drilling screws complying with AS 3566. Screws must be long enough to have a minimum embedment length of 35mm into the supporting member.

All fixings for ledgers, horizontal ties, putlogs and braces shall be not less than 2 nos 12 gauge screws to each standard.

Putlogs at each standard shall bear directly on the standard and be fixed to the standard as shown in Figure 27. The inside end of these putlogs shall be fixed to the building rafter with minimum one M12 bolt.

Intermediate putlogs shall be nailed to the upper surface of the ledger to secure them against dislodgement.

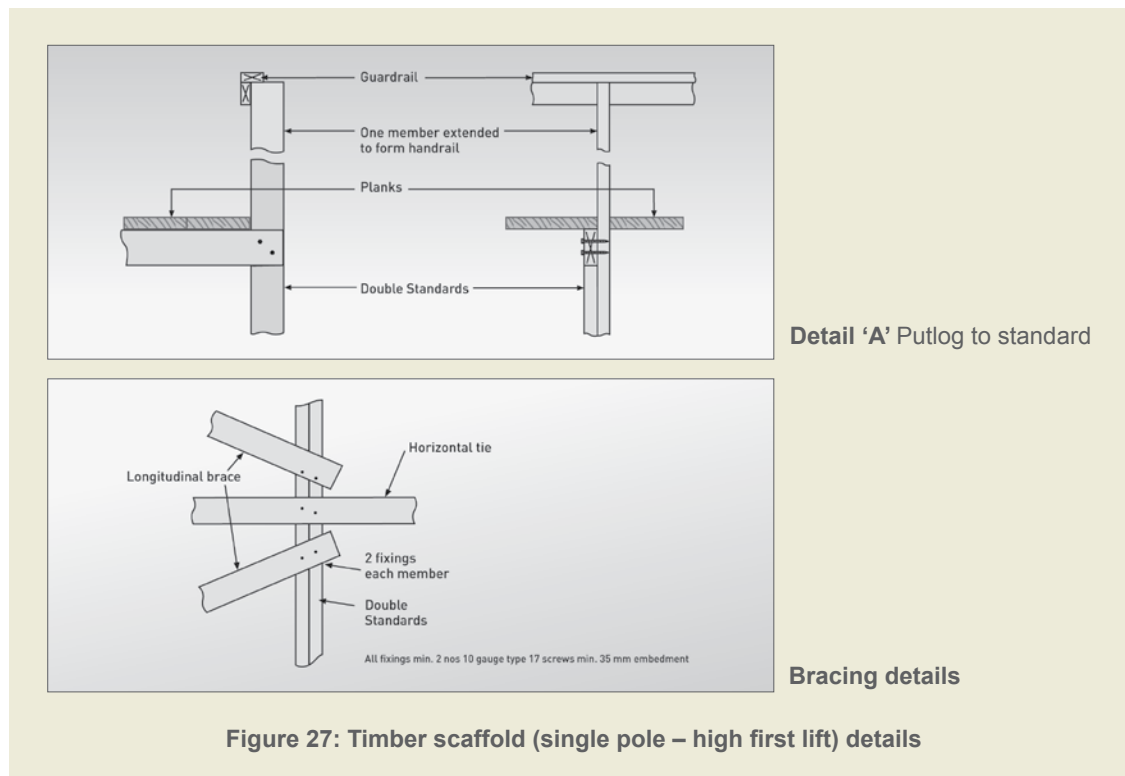



3.5 STANDARDS

Standards shall have a stress grading not less than:

- i. F8 unseasoned hardwood, or
- ii. MGP 12 seasoned pine.

The minimum cross-sectional dimensions and shall be in accordance with Table 5.

The maximum longitudinal spacing of standards shall be 2.7 metres.

Except as noted in this section, standards shall be constructed in accordance with Section 2.4

Standards

Height to working platform	Minimum (nominal) sizes
6.0m	2 nos 120 x 45
5.0m	2 nos 120 x 45
4.0m	2 nos 90 x 45
3.0m	2 nos 90 x 45

Table 5 - Standards

3.6 LEDGERS AND HORIZONTAL TIES

Each longitudinal row of standards shall be joined on the inside face with horizontal ties with their greater cross-sectional dimension vertical, extending the full length of the scaffold. At the working platform a ledger shall perform the function of a horizontal tie.

All horizontal ties shall be:

- a minimum size of 70 x 45 or 90 x 35 MGP 10 seasoned pine, and
- located at a maximum centre to centre vertical spacing of 2 metres with the lowest tie being not greater than 300mm above the sole plate.

A ledger of minimum size 120 x 35 F17 KDHW shall be fixed to the inside of each standard at the level of the working platform.

Joints in ledgers and horizontal ties shall be staggered and shall not occur:

- in vertically adjacent members in the same bay
- in the same member in the same bay, or
- in the end bays of a scaffold.

Joints in ledgers and horizontal ties shall be butted and spliced.



3.7 PUTLOGS

The scaffold shall be fixed in the transverse plane at the working platform lift. In this type of scaffold design the putlogs also perform the function of tying the scaffold to the building. Putlogs shall:

- be located at each standard
- putlogs shall be fixed to their support in accordance with Section 3.4, and
- be continuous along their length.

The cross-sectional dimensions and the maximum span of putlogs are set out in Table 6.

Putlogs

Span of putlog	Minimum sizes and grading
2.4m	140 x 45 F17 KDHW
1.8m	140 x 45 F17 KDHW
1.2m	150 x 50 F7 Oregon

Table 6 - Putlogs

3.8 BRACING

Longitudinal braces shall be fixed in each lift of the scaffold to the outside of the outer row of standards, with the distance between braced bays not exceeding three bays in length.

Braces shall be fixed diagonally as close as possible to the intersection of the standards and ledgers and, in the first lift, the lower end of a brace shall be fixed as close as possible to the intersection of the standard and its soleplate.

Braces shall be a minimum of F8 unseasoned hardwood or MGP 10 seasoned pine with nominal cross-sectional dimensions not less than 100 x 38mm.

3.9 SPLICING OF MEMBERS

Where members are spliced, such joints shall be butt joints with fishplates of the same cross-sectional dimensions fixed equidistant on each side of the butt point, and bolted through with four 12mm diameter mild steel bolts, washers and nuts, spaced at 225mm centres.

3.10 WORKING PLATFORM EDGE PROTECTION AND ACCESS

Working platforms shall be provided with edge protection and with safe means of access and egress in accordance with AS/NZS 4576.