

Australian Capital Territory

# Casino Control (American Roulette) Approval 2006 (No 1)\*

Notifiable Instrument NI2006—146

made under the

*Casino Control Act 2006*, s 96 (Rules for Authorised Games).

---

## 1 Name of instrument

This instrument is the *Casino Control (American Roulette) Approval 2006 (No 1)*.

## 2 Commencement

This instrument commences on 1 May 2006.

## 3 Approval

I approve the rules for the Authorised Game of “American Roulette” as set out in the attached schedule.

Greg Jones

Chief Executive Officer

ACT Gambling and Racing Commission

10 April 2006

\*Name amended under Legislation Act, s 60

**CASINO CANBERRA LIMITED**

**RULES**

**OF**

**AMERICAN ROULETTE**

## **AMERICAN ROULETTE CONTENTS**

<b>A.</b>	<b>DICTIONARY OF TERMS USED IN AMERICAN ROULETTE</b>	<b>3</b>
<b>B.</b>	<b>RULES OF AMERICAN ROULETTE</b>	<b>5</b>
<b>1.</b>	<b>AMERICAN ROULETTE TABLE</b>	<b>5</b>
<b>2.</b>	<b>AMERICAN ROULETTE WHEEL AND BALL</b>	<b>5</b>
<b>3.</b>	<b>MINIMUM AND MAXIMUM WAGERS</b>	<b>5</b>
<b>4.</b>	<b>WAGERS</b>	<b>6</b>
<b>5.</b>	<b>DEALING THE GAME</b>	<b>8</b>
<b>6.</b>	<b>PAYOUT ODDS</b>	<b>8</b>
<b>7.</b>	<b>SETTLEMENT OF WAGERS</b>	<b>8</b>
<b>8.</b>	<b>TABLE CLOSURE</b>	<b>9</b>
<b>9.</b>	<b>IRREGULARITIES</b>	<b>9</b>
<b>10.</b>	<b>GENERAL PROVISIONS</b>	<b>9</b>
<b>11.</b>	<b>RAPID ROULETTE</b>	<b>10</b>
<b>12.</b>	<b>SETTLEMENT OF RAPID ROULETTE WAGERS</b>	<b>11</b>
<b>13.</b>	<b>WAGERING PERIOD FOR RAPID ROULETTE</b>	<b>11</b>
<b>14.</b>	<b>RAPID ROULETTE ATS ACCOUNTS</b>	<b>11</b>
<b>15.</b>	<b>RAPID ROULETTE IRREGULARITIES</b>	<b>11</b>
<b>16.</b>	<b>TOURNAMENT PLAY</b>	<b>12</b>
<b>APPENDIX A</b>	<b>AMERICAN ROULETTE (SINGLE ZERO) WHEEL</b>	<b>15</b>
<b>APPENDIX B</b>	<b>AMERICAN ROULETTE (DOUBLE ZERO) WHEEL</b>	<b>16</b>
<b>APPENDIX C</b>	<b>WAGERS ON AMERICAN ROULETTE</b>	<b>17</b>
<b>APPENDIX D</b>	<b>WAGERS ON THE RACETRACK</b>	<b>18</b>
<b>APPENDIX E</b>	<b>AUTOMATED TOUCH SCREEN (ATS)</b>	<b>19</b>

## **A. DICTIONARY OF TERMS USED IN AMERICAN ROULETTE**

(nb. terms defined in the dictionary are underlined throughout this document.)

### **Approved**

Means approved in writing by the ACT Gambling and Racing Commission.

### **ATS**

An Automated Transaction Station featuring a touch screen monitor designed to allow a player to place wagers on a Rapid Roulette layout.

### **ATS Chip Account**

An Automated Transaction Station Chip Account is used to increase or decrease a patron's ATS chip account with electronic chips of a predetermined value according to buy-in, win or loss.

### **Ball**

An approved non-metallic ball used in the game as described in Rule 2.2.

### **Casino Operator**

The organisation or person responsible for the conduct of gaming in the casino.

### **Casino Supervisor**

A person responsible for the supervision of the operation of the game.

### **Colour Chips**

Chips used to help distinguish players' bets that have a nominated value and that may only be used at the table at which they were purchased.

### **Dealer**

A person responsible for the operation of the game.

### **Dolly**

A marker used to indicate the winning number.

### **Electronic Chips**

A virtual chip used on Rapid Roulette. All transactions using electronic chips are treated as per table gaming chips.

### **Marker Button**

A round object used to denote the value of colour chips when that value is higher than the table minimum.

### **Maximum Marker**

A pair of triangular objects of the same colour used to accept a maximum bet on a single number.

**Neighbour/Section Buttons**

Buttons that are used when making a wager on a number and its neighbouring numbers (eg. 3, 26, 0, 32, 15) or on sections of the wheel as described in Rule 4.10.

**Racetrack**

An area of the approved layout used for neighbour and section wagers.

**Round of Play**

That part of the game that commences when the dolly is removed from the layout and concludes once all payouts have been completed.

**Session**

A session is the number of rounds of play or number of spins, determined by the structure of the tournament.

**Stake Buttons**

A pair of round objects of the same colour used to accept a cash wager on the even chances, columns and dozens.

**Tournament Chips**

Chips that cannot be exchanged for money, are distinguishable from all other casino chips, and are used exclusively for the playing of tournaments.

**Tournament Commission**

The amount the casino operator collects from players as payment to the casino operator for conducting the game.

**Tournament Director/Assistant**

The person responsible for the conduct of the tournament.

**Void**

Neither the player nor the dealer wins and any chips wagered or paid shall be returned as if the round of play had not occurred.

**Wagering Period**

The period where the placement of wagers via the ATS of the Rapid Roulette game system is permitted.

**Wheel**

An approved apparatus described in Rule 2.1 used to determine the outcome of a game.

**Winning Number Display (WND)**

A device visible to players showing the outcome of recent spins of the Rapid Roulette game system.

## **B. RULES OF AMERICAN ROULETTE**

### **1. AMERICAN ROULETTE TABLE**

1.1 An American Roulette table shall be approved prior to use.

### **2. AMERICAN ROULETTE WHEEL AND BALL**

2.1 An American Roulette wheel shall be approved prior to use. The numbers shall be arranged around the wheel in accordance with either Appendix A or Appendix B.

2.2 Each ball used in the game of American Roulette shall be approved prior to use.

2.3 The ball may be changed at any time with the casino supervisor's authorisation.

### **3. MINIMUM AND MAXIMUM WAGERS**

3.1 The casino operator shall display the minimum and maximum wagers at the table and may change these limits provided that prior notice of the change is given to the players.

3.2 The casino operator may allow a player to wager in excess of the stated maximum provided that a marker denoting the new limit is placed adjacent to the player.

3.3 The multiples of wagers allowable shall be displayed at the table.

3.4 Wagers below the minimum shall be paid or collected and the owner of the wager shall be advised that further wagers under the minimum shall be returned.

3.5 Wagers above the displayed maximum shall be paid or collected to the maximum.

#### 4. WAGERS

- 4.1 Prior to the announcing or displaying of “NO MORE BETS” each player shall be given the opportunity to place a wager.
- 4.2 All wagers shall be made by placing either gaming chips, colour chips, electronic chips, stake buttons or a maximum marker on the appropriate area(s) of the layout.
- 4.3 Where an approved Rapid Roulette system is used, wagers can only be made using an Automated Touch Screen (ATS).
- 4.4 The following wagers, as illustrated in Appendix C, are permitted:
- (a) Straight Up - which is a wager on any one number, Double Zero or Zero;
  - (b) Split - which is a wager on two numbers which are adjacent on the layout;
  - (c) Street - which is a wager on three numbers which are adjacent in one row on the layout or Zero, 1 and 2 or Zero, 2 and 3 and where a Double Zero wheel is used, Zero, 1 and 2, or Zero, Double Zero and 2, or Double Zero, 2 and 3;
  - (d) Corner - which is a wager on four numbers which are adjacent on the layout;
  - (e) Five-line - which, where a Double Zero wheel is used, is a wager on five numbers, Zero, Double Zero, 1, 2 and 3;
  - (f) Six-line - which is a wager on six numbers which are adjacent on the layout;
  - (g) Column - which is a wager on twelve numbers which are adjacent in one column on the layout;
  - (h) Dozen - which is a wager on twelve numbers in a particular dozen (1-12, 13-24, or 25-36);
  - (i) Low - which is a wager on the numbers 1 – 18;
  - (j) High - which is a wager on the numbers 19 – 36;
  - (k) Even - which is a wager on all the even numbers;
  - (l) Odd - which is a wager on all the odd numbers;
  - (m) Red - which is a wager on all the red numbers around the wheel; and
  - (n) Black - which is a wager on all the black numbers around the wheel.

- 4.5 Once the "NO MORE BETS" has been announced or displayed no player shall handle, remove or alter the original wager, or place an additional wager, until a decision has been rendered and implemented on that wager.
- 4.6 Each player shall be responsible for the correct positioning of their wager regardless of whether or not they are assisted by the dealer. It is each player's responsibility to ensure that any instructions given to the dealer regarding the placement of a wager is correctly carried out.
- 4.7 The casino operator or its employees may require a player to use colour chips.
- 4.8 Where stake buttons are used, one stake button will be placed on the layout to represent the cash wager and the other stake button will stay with the cash until it can be counted. A stake button wager shall only be accepted if the exact money is tendered, subject to Rule 3.5.
- 4.9 A maximum marker may be used where a player requests to place the maximum wager on a single number and the combinations of that number. The dealer shall place a maximum marker for the wager on the layout and an identical maximum marker with the correct amount of chips for that particular maximum wager on the perimeter of the wheel.
- 4.10 Where a racetrack or neighbour/section buttons are used, wager/s requested by a player must be placed on the layout or on the appropriate area of the racetrack before "NO MORE BETS" is announced.

Wagers permitted on the racetrack or with neighbour/section buttons, as illustrated in Appendix D, are:

- (a) Serie 5/8 - Tier (six piece wager)  
5/8, 10/11, 13/16, 23/24, 27/30 and 33/36;
- (b) Orphelins - Orphans (five piece wager)  
1, 6/9, 14/17, 17/20 and 31/34;
- (c) Serie 0/2/3 - Voisin de Zero (nine piece wager)  
0/2/3, 4/7, 12/15, 18/21, 19/22, 25/26/28/29 and 32/35;
- (d) 0-Spel - Zero Game (four piece wager)  
0/3, 12/15, 26 and 32/35; and
- (e) Voisins - Neighbours (five piece wager)  
a specific number with the two numbers either side of it on the wheel.



## 5. DEALING THE GAME

- 5.1 The dealer shall spin the ball in the opposite direction to the rotation of the wheel.
- 5.2 To constitute a valid spin the ball shall complete at least three revolutions around the track of the wheel.
- 5.3 “NO MORE BETS” shall be:
- (a) announced and indicated by the dealer prior to the ball coming to rest in the wheel; or
  - (b) where the Rapid Roulette game system is used, displayed on the ATS prior to the ball coming to rest in the wheel.
- 5.4 No person, other than a casino employee shall at any time interfere with the wheel or the ball.

## 6. PAYOUT ODDS

- 6.1 Winning wagers shall be paid as follows:

<b>WAGERS</b>	<b>PAYOUT ODDS</b>
(a) Straight up	35 to 1
(b) Split	17 to 1
(c) Street	11 to 1
(d) Corner	8 to 1
(e) Five line (Double Zero <u>wheel</u> only)	6 to 1
(f) Six line	5 to 1
(g) Column	2 to 1
(h) Dozen	2 to 1
(i) Low	1 to 1
(j) High	1 to 1
(k) Even	1 to 1
(l) Odd	1 to 1
(m) Red	1 to 1
(n) Black	1 to 1

## 7. SETTLEMENT OF WAGERS

- 7.1 A wager shall win if the number in which the ball has come to rest is the number wagered on or is one of a combination of numbers wagered on.

7.2 Each wager shall be settled in accordance with its position on the layout when the ball falls to rest in a compartment of the wheel, subject to wagers placed in accordance with Rules 4.8, 4.9 and 4.10.

7.3 When the result is Zero or Double Zero:

(a) wagers placed on Zero or Double Zero or on a combination of Zero and/or Double Zero with 1 and/or 2 and/or 3, shall win at odds in accordance with Rule 6.1; and

(b) all other wagers shall lose.

## **8. TABLE CLOSURE**

8.1 The hours of gaming shall be as determined under the provisions of the *Casino Control Act 2006*.

8.2 Subject to Rule 8.1, the casino operator may close any table before the close of gaming provided that notice is given to the players.

## **9. IRREGULARITIES**

9.1 If the ball is spun in the same direction in which the wheel is rotating it is a void spin.

9.2 If the dealer anticipates that the ball will not complete three revolutions around the track of the wheel, the dealer shall announce "NO SPIN" and shall attempt to remove the ball from the wheel prior to its coming to rest in one of the compartments.

9.3 If a foreign object enters the wheel prior to the ball coming to rest, the spin is void.

9.4 If the ball fails to fall into one of the compartments, the spin is void.

9.5 If the ball is propelled or falls out of the wheel, the spin is void.

## **10. GENERAL PROVISIONS**

10.1 The casino operator may invalidate the outcome of a game if the game is disrupted by civil commotion, fire, riot, brawl, robbery, or any like disturbance.

- 10.2 Where a person has contravened any provision of these rules, the casino operator may:
- (a) declare any wager made by that player void; and
  - (b) direct that the player be excluded from further participation in the game.
- 10.3 The casino operator may declare a round of play void if it is impractical to continue or a person commits a fraudulent act that affects the outcome for that particular round of play.
- 10.4 The casino operator's decision in any dispute arising from these rules is final, subject to a review by the ACT Gambling and Racing Commission if requested.
- 10.5 An employee of the casino shall:
- (a) not advise a player on how to play, except to ensure compliance with these rules;
  - (b) not give or allow any advantage to a person, or cause or allow a change in any probabilities of the game by any means other than that covered by these rules; and
  - (c) commensurate with their responsibilities, ensure that the game is conducted in accordance with the approved procedures.
- 10.6 A seated player who abstains from betting for three consecutive rounds of play whilst all other seats at that table are in use may be required to vacate that seat.
- 10.7 A person shall not instruct or influence another player's decision of play.
- 10.8 Players are not permitted to have side bets with each other.
- 10.9 Upon request the casino operator shall make a copy of these rules available.
- 11. RAPID ROULETTE**
- 11.1 A Rapid Roulette game system shall be approved prior to use.
- 11.2 Rapid Roulette is played on a virtual layout using electronic chips through an ATS chip account.

## **12. SETTLEMENT OF RAPID ROULETTE WAGERS**

- 12.1 Each wager will be settled electronically, by appropriate adjustment to a patron's ATS chip account, in accordance with payout odds relative to its position on the virtual layout when the ball falls to rest in a compartment of the wheel.
- 12.2 A minimum aggregate wager per spin may be set by the casino operator.
- 12.3 If by the end of the wagering period, a player has placed one or more wagers which are in aggregate less than the permitted aggregate wager (if any), those wagers will not be recognised by the ATS or the game system for the spin.

## **13. WAGERING PERIOD FOR RAPID ROULETTE**

- 13.1 The casino operator may determine how long the wagering period will be for the game.

## **14. RAPID ROULETTE ATS ACCOUNTS**

- 14.1 An ATS must display the active ATS chip account value.
- 14.2 A person wishing to play the game must buy in by either:
- (a) tendering to the dealer an amount of cash, vouchers, authorised tokens or chips; or
  - (b) where the ATS has a note acceptor, placing an amount of cash directly into the note acceptor.

## **15. RAPID ROULETTE IRREGULARITIES**

- 15.1 If the ball comes to rest before the end of the wagering period, the spin is void.
- 15.2 The WND must be disregarded if the WND displays a number other than the actual outcome.
- 15.3 If an ATS experiences a malfunction prior to the expiry of the wagering period, the dealer must void all wagers placed on the ATS for the relevant spin.

- 15.4 If an ATS experiences a malfunction on or after the expiry of the wagering period, the dealer must seek to confirm what wagers were placed through the analysis of available records and cause the appropriate adjustments to be made.
- 15.5 If the game system (other than an ATS) experiences a malfunction (including by reason of physical damage) prior to the expiry of the wagering period, the dealer must void all wagers placed by all players for the relevant spin.
- 15.6 If the game system (other than an ATS) experiences a malfunction (including by reason of physical damage) on or after the expiry of the wagering period, the dealer must seek to confirm what wagers were placed through the analysis of available records and cause the appropriate adjustments to be made.
- 15.7 If the casino operator is unable, for the purposes of Rule 15.6, to confirm the relevant wagers placed through the analysis of available records, the dealer must void those wagers.

## **16. TOURNAMENT PLAY**

- 16.1 In addition to the rules set out in the preceding paragraphs and Appendices, the rules of this section shall apply only to tournament play.
- 16.2 The Gaming Shift Manager shall nominate a person, known as the Tournament Director/Assistant.
- 16.3 The conditions of entry and of play for each American Roulette tournament shall be approved.
- 16.4 The conditions of the tournament may include the following:
- (a) the tournament starting date and time;
  - (b) the heat structure of the tournament;
  - (c) the entry fee and tournament commission;
  - (d) the amount of tournament chips each player will receive for the entry fee;
  - (e) the minimum and maximum number of players;
  - (f) restrictions on player groups;
  - (g) the table limits; and
  - (h) the breakdown of the prize pool.

- 16.5 Where the conditions of entry and play for tournament play approved under Rule 16.3 are inconsistent with the rules set out in the preceding paragraphs and in the Appendices, the conditions approved under Rule 16.3 shall prevail for the duration of the tournament.
- 16.6 The Tournament Director/Assistant shall allow players one entry only into the tournament.
- 16.7 The Tournament Director/Assistant shall allocate each player a table and seat position by ballot before the commencement of a session and the player is restricted to playing in the assigned position for the duration of that session.
- 16.8 The Tournament Director/Assistant shall determine the number of players allocated to any one table.
- 16.9 All entrants shall take their allocated seat prior to the published starting time. If at the commencement of a session an entrant has not taken their allocated seat, the entrant shall be deemed to have forfeited their position. The entry fee paid by the entrant is forfeited and remains as part of the prize pool.
- 16.10 Where a player has not taken their seat prior to the commencement of the first session the Tournament Director/Assistant may offer that seat to a reserved player on payment of the specified entry fee for the tournament.
- 16.11 Approval for a substitute player shall be at the discretion of the Tournament Director/Assistant.
- 16.12 All tournament chips shall remain in full view of the players and the Tournament Director/Assistant while the tournament is in progress.
- 16.13 Players shall not remove, add to, exchange or reduce their amount of tournament chips other than in accordance with these rules.
- 16.14 All players shall wager and risk at least the table minimum for each round of play. Any player who cannot wager at least the table minimum before the commencement of a round of play shall be eliminated from the tournament and must vacate their seat.
- 16.15 The Tournament Director/Assistant may offer the players the opportunity to take a break during the tournament and shall specify the amount of time allowed for the break.
- 16.16 The Tournament Director/Assistant may determine the speed at which the tournament shall be played and may give direction to players in order to achieve that rate of play.

- 16.17 The Tournament Director/Assistant shall be responsible for calculating and awarding the places.
- 16.18 The casino operator shall return 100% of the prize pool to the players by way of prizes.
- 16.19 In the event of two or more players holding an equal value of tournament chips at the completion of any heat, semi-final or the final session, those players shall be given additional rounds of play until a result is achieved.
- 16.20 In the event that a round of play results in two or more players contesting the same division of the prize pool, the prize money shall be combined and split equally between those players.
- 16.21 The casino operator may charge an entry fee for the tournament and may retain an approved amount of the total entry fees as tournament commission. The casino operator shall offer the balance of the entry fees as prize money in accordance with the approved conditions of tournament play.
- 16.22 All entry fees and tournament commissions are non-refundable. The casino operator reserves the right to cancel the tournament without liability. In the event of cancellations, the casino operator shall refund all entry fees and tournament commissions in full.

**APPENDIX A**

**The American Roulette (Single Zero) Wheel**

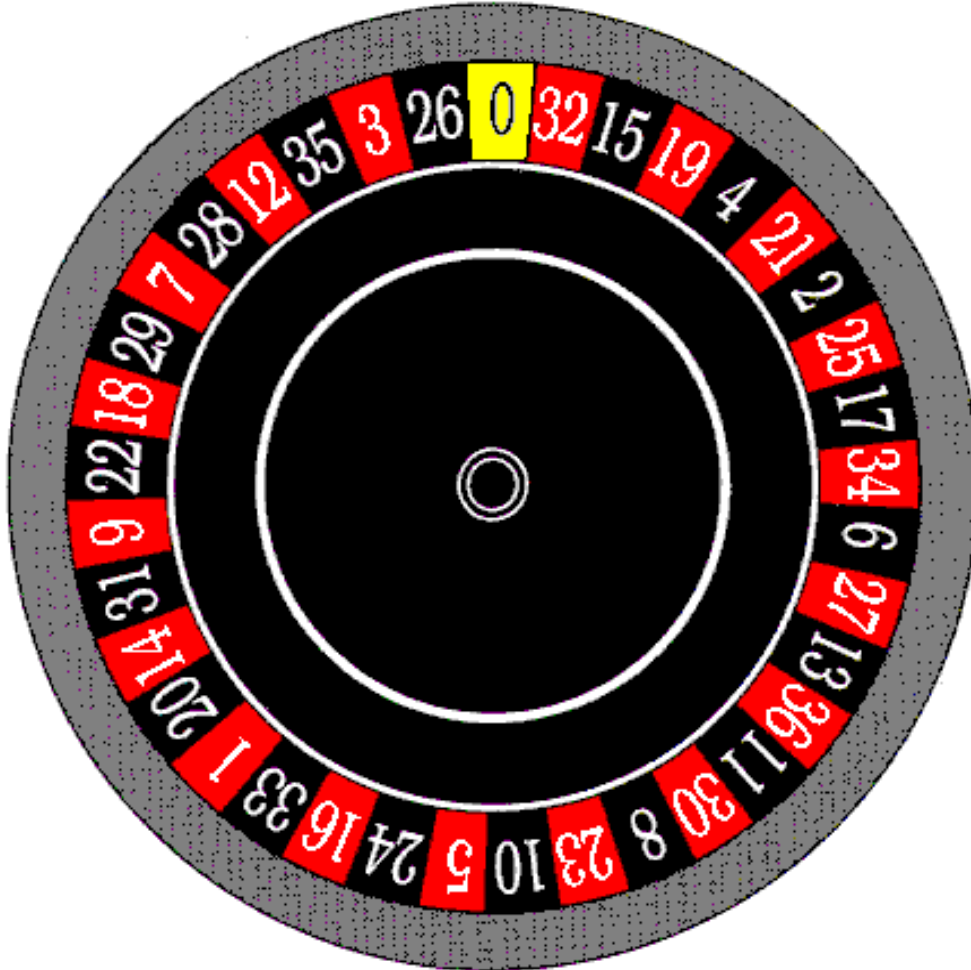



**APPENDIX B      American Roulette (Double Zero) Wheel**

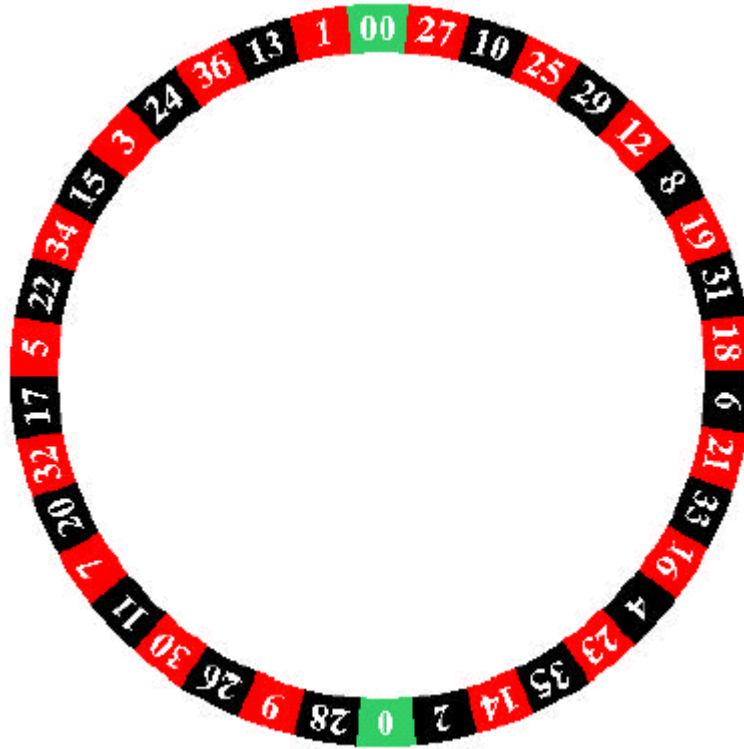

**APPENDIX C**

**Wagers on American Roulette**

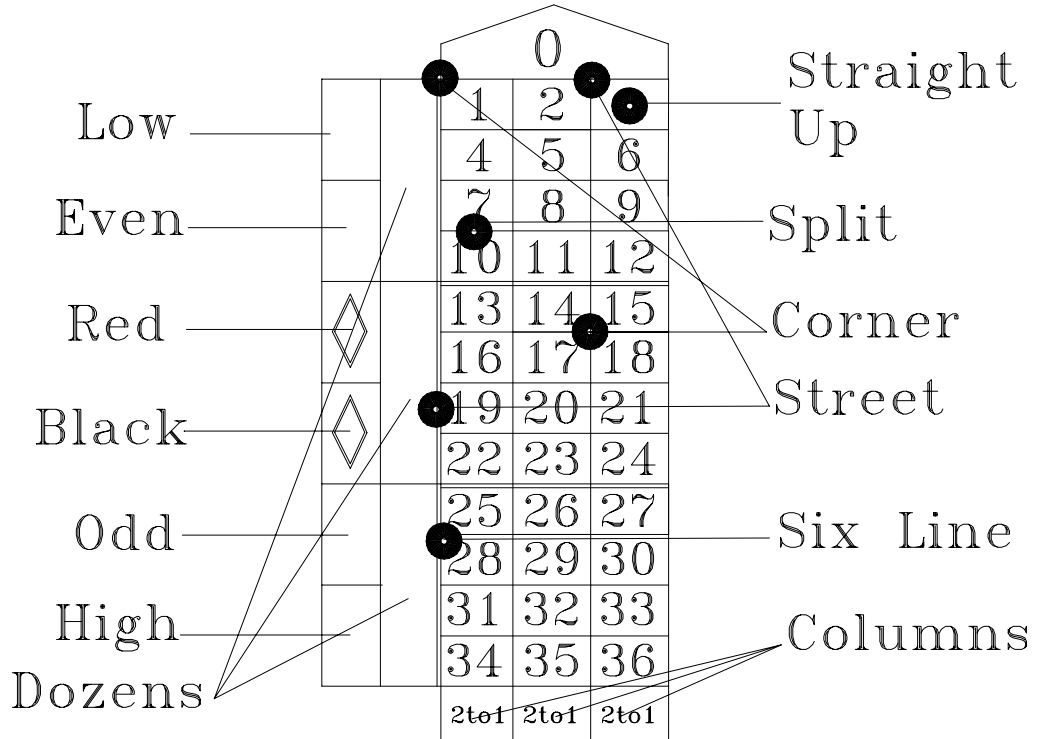

**APPENDIX D**

**Wagers on the Racetrack**

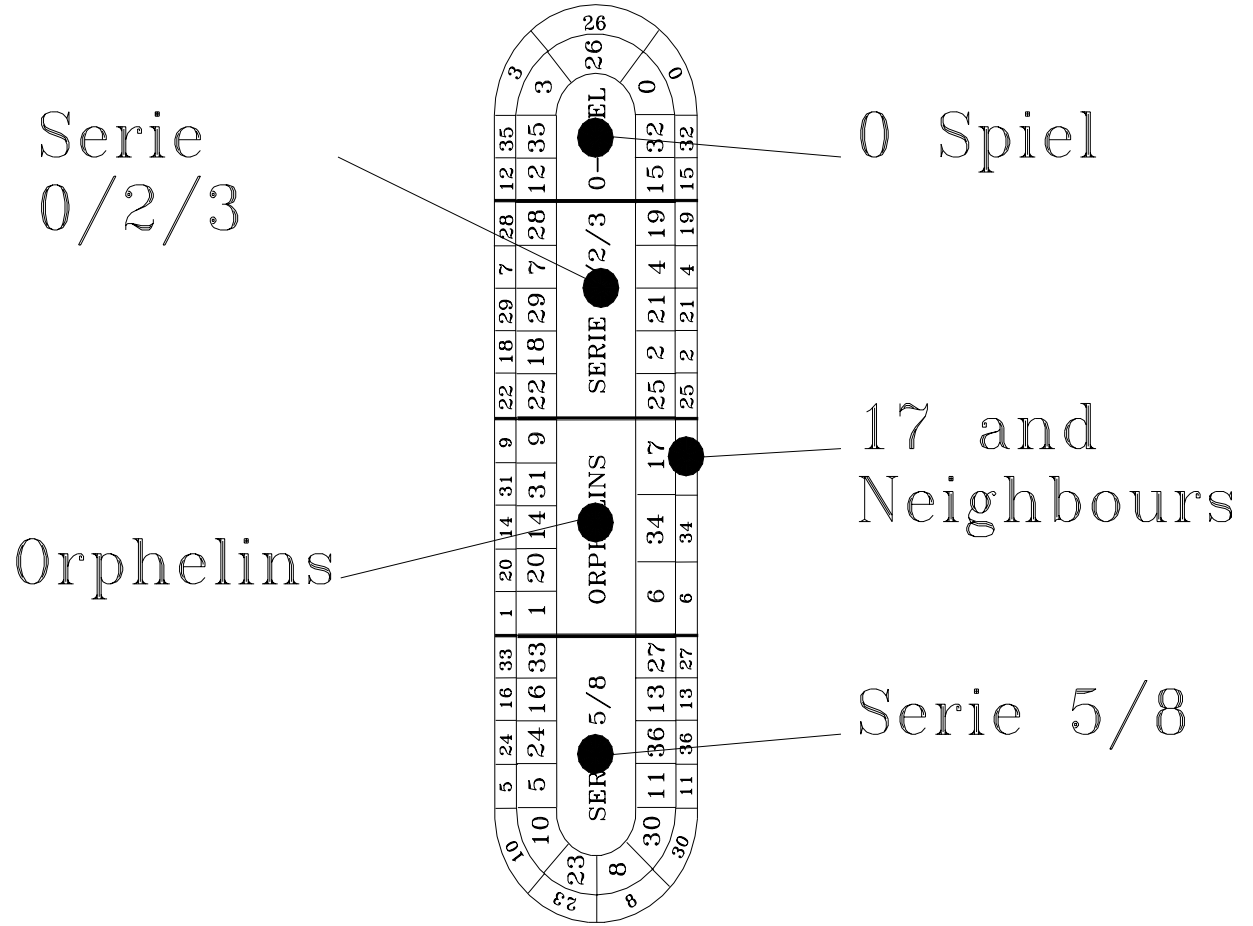

**APPENDIX E**

**Automated Touch Screen (ATS)**

