

Australian Capital Territory

# Planning and Development (Bus Shelter Master Plan) Approval 2008 (No 1)

Notifiable instrument NI2008—419

made under the

Planning and Development Regulation 2008, sch 1 s 1.90 (Minor public works)

---

## 1 Name of instrument

This instrument is the *Planning and Development (Bus Shelter Master Plan) Approval 2008 (No 1)*.

## 2 Commencement

This instrument commences on the day after it is notified.

## 3 Approval

Advertising and Non Advertising Bus Shelters in the ACT Master Plan (Revision 3, August 2008) has been approved by the Planning and Land Authority.

The bus shelter master plan provides a plan for the location of bus shelters as detailed in Annexure A.

Neil Savery  
Chief Planning Executive  
Planning and Land Authority  
10 September 2008



CLIENTS | PEOPLE | PERFORMANCE

Roads ACT

# Advertising and Non Advertising Bus Shelters in the ACT

Master Plan Revision 3

August 2008



# Contents

Executive Summary	1
1. Introduction	3
2. Proposed Bus Shelter Sites	5
2.1 General	5
2.2 Selection of Remaining Sites for Bus Shelters	6
2.3 Consistency of Shelter Type within Precincts and along Transport Corridors	7
3. Phasing of Shelter Construction	10
3.1 General	10
3.2 Phase 1	10
3.3 Phase 2	10
3.4 Phase 3	11
4. Shelter Design	12
5. Advertising	13
5.1 Size and Location of Advertising Panels	13
5.2 Movable Advertising Panels	13
5.3 Lighting of Advertising Panels	13
5.4 Advertising Content	13

## Table Index

Table 1 Proposed Shelter Distribution for Phase 2 and 3	5
---	---

## Appendices

- A Bus Shelter Site Evaluation Criteria
- B Bus Shelter Justification
- C Bus Shelter Design
- D Bus Shelter Location Drawings



## Executive Summary

1. In December 2006, the ACT Government signed a contract with ADSHEL Street Furniture Pty Ltd for the supply, installation and maintenance of 241 bus shelters, at no cost to Government. These comprised:

- » 133 illuminated advertising bus shelters;
- » 108 illuminated non-advertising bus shelters.

The contract also includes:

- » The relocation of approximately 75 existing shelters to sites nominated by the ACT Government to allow the erection of advertising or non advertising bus shelters in place of the existing shelters.

The erection and maintenance of all new shelters will be cost neutral to the ACT government with the advertising revenues by Adshel offsetting their costs of the infrastructure.

The contract maintenance period is 15 years. Construction of the bus shelters will be phased over a 3-year period.

Sites for a number of both the new shelters and the relocated shelters have not yet been finalised.

The principles guiding the rollout of the bus shelters are:

- » All proposed shelter locations shall meet at least one of the Demand Criteria for the Installation of New Bus Shelters prepared by ACTPLA and Roads ACT (refer Appendix A);
- » Advertising bus shelters are generally to be constructed in the City, Town Centres and on major transport routes connecting these centres. Construction of the shelters in these areas provides bus shelters on the most heavily used bus routes and, with high volumes of pedestrian and road traffic, will provide the best locations for advertising;
- » Non advertising shelters will be located:
  - at group centres,
  - in suburban areas; and
  - in locations in the City, Town Centres and on major transport routes where advertising shelters are not proposed but where a shelter is justified and a new shelter is desirable (e.g. for consistency of structure types within an area).

This Masterplan provides details of the shelters to be constructed under the contract with ADSHEL Street Furniture Pty Ltd. Under the relevant legislation, shelters covered by this Masterplan do not require individual Development Approval from ACTPLA.

The purpose of this master plan is:

- » To highlight how Phase 1 was executed.
- » To summarise ADSHEL's current proposals for the project;
- » To demonstrate how a consistent design solution will be achieved across nominated travel routes and precincts throughout the rollout;
- » To outline how the delivery of the bus shelters is to be phased;



» To outline how sites not yet identified are to be selected for inclusion in the project.

**2.** As part of Phase 1, Adshel constructed 35 advertising shelters and 18 non-advertising shelters which have been focused around the town centres of Belconnen, Woden, City, Tuggeranong and Barton. Adshel also relocated two concrete bunkers to secondary sites in Mawson and Warramanga.

To date, Roads ACT and Adshel have identified an additional 166 possible bus stops for construction of the remaining 188 new advertising and non-advertising shelters. Roads ACT have also identified 35 sites of the potential 73 sites required to receive a relocated existing shelter in Phases 2 and 3.

In Phase 2 and 3 of the project at least an additional 20 sites will need to be identified to receive a new shelter, however it is likely that more sites will need to be considered due to some of the selected sites failing to meet Roads ACT and Adshel requirements. Given there is some degree of uncertainty as to which sites will be selected to receive a new Adshel shelter it is difficult to determine the number of sites required to receive a relocated shelter. However it is known that as part of Phase 2 and 3 additional sites will need to be determined to receive a relocated shelter.

In Phase 2 and 3 of the project approximately 40 more sites will be identified by Roads ACT to receive an existing relocated shelter in these phases. It is also possible that additional sites may need to be identified to receive an advertising or non-advertising Adshel shelter as the currently proposed site list is not definitive and some sites may not meet Roads ACT requirements.

Any additional sites still to be identified will be selected by Roads ACT in consultation with ADSHEL from:

- » Sites requested by the public;
- » Sites suggested by ACTION based on passenger numbers;
- » Sites requested by the ADSHEL Street Furniture Pty Ltd based on commercial criteria;
- » Sites requested by Roads ACT.

An important objective of the project is to achieve an acceptable aesthetic outcome through providing a consistency in shelter types within different precincts within Canberra and along the major transport routes.

**3.** Construction of the bus shelters will be phased over a 3-year period in three phases:

- » Phase 1 completed in March 2008 involved the construction of 53 new bus shelters.
- » Phase 2 to be completed by mid 2009 involves the construction of 98 new Adshel shelters. Where sites to receive a new shelter already have a shelter, the existing shelter will be relocated to a secondary site within the ACT. Phase 2 will thus result in a net benefit of 98 shelters on sites currently without shelters.
- » Phase 3 to be completed by the end of 2009 involves the construction of 90 new Adshel shelters. Where sites to receive a new shelter already have a shelter, the existing shelter will be relocated to a secondary site within the ACT. Phase 3 will thus result in a net benefit of 90 shelters on sites currently without shelters.

**4.** All new shelters will be of the ADSHEL EVO Mk II type. Refer to Appendix C for plans and photographs of the proposed structures.



# 1. Introduction

In December 2006, the ACT Government signed a contract with ADSHEL Street Furniture Pty Ltd for the supply, installation and maintenance of 241 bus shelters at no cost to Government. These include:

- » 133 illuminated advertising bus shelters;
- » 108 illuminated non-advertising bus shelters.

The contract also includes the relocation of roughly 75 existing shelters throughout all three phases to sites nominated by the ACT Government to allow the erection of advertising or non advertising bus shelters in place of the existing shelters.

The erection and maintenance of all new shelters will be cost neutral to the ACT government with the advertising revenues by Adshel offsetting their costs of the infrastructure.

The contract maintenance period is 15 years. Construction of the bus shelters will be phased over a 3-year period.

Sites for a number of both the new shelters and the relocated shelters have not yet been finalised.

The principles guiding the rollout of the bus shelters are:

- » All proposed shelter locations shall meet at least one of the Demand Criteria for the Installation of New Bus Shelters prepared by ACTPLA and Roads ACT (refer Appendix A);
- » Advertising bus shelters are generally to be constructed in the City, Town Centres and on major transport routes connecting these centres. Construction of the shelters in these areas provides bus shelters on the most heavily used bus routes and, with high volumes of pedestrian and road traffic, will provide the best locations for advertising;
- » Non advertising shelters will be located:
  - at group centres,
  - in suburban areas; and
  - in locations in the City, Town Centres and on major transport routes where advertising shelters are not proposed but where a shelter is justified and a new shelter is desirable (e.g. for consistency of structure types within an area).

This Masterplan provides details of the shelters to be constructed under the contract with ADSHEL Street Furniture Pty Ltd. Under the relevant legislation, shelters covered by this Masterplan do not require individual Development Approval from ACTPLA.

The purpose of this master plan is:

- » To highlight how Phase 1 was executed.
- » To summarise ADSHEL's current proposals for the project;
- » To demonstrate how a consistent design solution will be achieved across nominated travel routes and precincts throughout the rollout;
- » To outline how the delivery of the bus shelters is to be phased;
- » To outline how sites not yet identified are to be selected for inclusion in the project.



The details included in this masterplan provide an indication of the objective of the project. However it is expected that some variation in the following may take place:

- » Shelter locations have not been finalised and may vary as more research is carried out into the proposed sites.
- » Phasing is subject to change dependent on approvals.
- » Shelters that have been approved as ad sites which are not utilised by Adshel for advertising but are still deemed to require a new shelter may be used as non ad sites without further approval by ACTPLA.



## 2. Proposed Bus Shelter Sites

### 2.1 General

Under the contract Adshel is required to construct 241 new shelters at sites around the ACT. To date, 219 bus stops have been identified with the potential to receive a new Adshel shelter; one stop nominated in the inner south and one stop in Belconnen are proposed to have double shelters. The sites identified for new shelters may result in approximately 75 existing shelters throughout Phase 1, 2 and 3 requiring relocation to sites nominated by Roads ACT across Canberra.

Phase 1 involved the construction of 53 of these new Adshel shelters and two concrete bunker relocations.

The distribution of the remaining 166 identified sites for Adshel shelters in Phase 2 and 3 is summarised in Table 1.

**Table 1 Proposed Shelter Distribution for Phase 2 and 3**

Location	Total Number of Sites
Gungahlin Town Centre	4
Gungahlin Suburban	20
Belconnen Town Centre	5
Belconnen Suburban	24
City/Inner North	38
Inner South	24
Weston Creek	5
Woden Town Centre	4
Woden Suburban	13
Tuggeranong Town Centre	5
Tuggeranong Suburban	24
TOTALS	166

The project concentrates on the City, Town centres and Group Centres and on major transport routes connecting these activity nodes (i.e. high activity areas which provide the best return for both advertisers and bus users).

The first phase has been executed with an aim to a spread of shelters with a focus on the City and Town Centres.

The second phase focuses on the city and busy transportation routes within Canberra. While the third phase is developed to provide shelters to well used suburban stops.





Bus shelter proposals for the currently identified 168 possible new Adshel shelters to be located on the 166 sites described in table 1 and 35 identified relocation sites for Phase 2 and 3 are shown in the drawings in Appendix D.

Thus far 168 advertising and non advertising bus shelters (including the two double shelters) have been identified by Roads ACT and Adshel. These are currently broken into 102 proposed advertising and 66 non advertising shelters; this includes the two double shelter stops, where the site located in the inner south will have one advertising and one non advertising shelter while the double shelter in Belconnen will have two advertising shelters. Under the contract for Phase 2 and 3 Adshel are required to build 98 advertising and 90 non advertising shelters. This results in an excess of advertising sites and a short fall of non-advertising sites. While advertising sites can be converted to non advertising sites without further approval these sites were selected by Adshel and may not represent Roads ACT's needs for a non advertising site. Therefore it is possible that more sites for either advertising or non advertising shelters may need to be selected even if an excess of the other exists.

Furthermore 73 Phase 2 and 3 sites with an existing shelter have been flagged to potentially receive a new shelter. As part of the contract bus stops with existing shelters can receive a new shelter for the following reasons:

- » Adshel request the site for Advertising;
- » The replacement of this shelter creates a uniform and aesthetically pleasing precinct;

Roads ACT have currently identified 35 sites suitable to receive a relocated shelter and are in the process of determining up to 38 more sites.

All bus stops to be erected as part of the project must comply with at least one of the criteria developed by Roads ACT and ACTPLA (refer Appendix A). In addition Roads ACT will carry out checks on all sites in Phases 2 and 3 to confirm that the community is in fact using them.

## **2.2 Selection of Remaining Sites for Bus Shelters**

The sites to receive a relocated shelter still to be identified and any additional advertising or non advertising sites required due to the failure of any of the identified sites to meet ACTPLA approval will be selected by Roads ACT in consultation with ADSHEL from:

- » Sites requested by the public;
- » Sites suggested by ACTION based on passenger numbers;
- » Sites requested by the ADSHEL Street Furniture Pty Ltd based on commercial criteria;
- » Sites requested by Roads ACT.

Under the current legislation, sites that Roads ACT nominates to receive a relocated shelter do not require further approval.

However any sites not included in this Masterplan but which are later identified for erection of an Adshel shelter will first be reviewed to ensure consistency with at least one of the criteria in Appendix A. They will then need to be approved by ACTPLA through the usual Development Applications process.



## 2.3 Consistency of Shelter Type within Precincts and along Transport Corridors

An important objective of the project is to achieve an acceptable aesthetic outcome through providing a consistency in shelter types within different precincts within Canberra and along the major transport routes.

The location of new shelters within precincts and along major transport routes within Canberra is discussed in the following sections.

### 2.3.1 Precincts

In this report, precincts are defined as areas within Canberra that have a homogeneous character. They include the City, Town Centres and other residential or business areas whose boundaries are reasonably well defined. These precincts are generally major bus and general traffic generators.

#### ***City/Inner North***

There are a number of existing shelters in the city, in particular in the vicinity of the bus interchange.

In Phase 1, 13 new shelters were installed in locations throughout the City and Inner north. In Phase 2 and 3, 38 new shelters are proposed on sites currently with and without shelters throughout the city.

At the completion of Phase 3 most of the existing shelters in the City and inner north will have been replaced with the new structure type. The upgrading of most of these structures will create a sense of uniformity and modernisation throughout the city while continuing to provide commuters in this busy transport area with protection. These shelters are also ideal for advertising exposure to both pedestrian and passing traffic.

At the completion of the project existing shelters will be left in several locations throughout the city; these are as follows:

- » At the interchange (existing steel and glass structures)
- » Several concrete bunkers scattered through the suburbs of the Inner North.
- » Shelters in the city which due to their location are not utilised by commuters and do not provide good advertising opportunities.

For consistency along Northbourne Ave all existing shelters are proposed to be upgraded as part of Phase 2.

#### ***Barton/Forrest***

Phase 1 saw the installation of five new shelters within Barton and Forrest. Following on from the work in Phase 1, Phase 2 focuses heavily on upgrading shelters in the employment node of Barton and Forrest. This area generates a large number of commuters from the surrounding offices. Additional shelters are therefore warranted and, because of the high profile nature of the area it is considered desirable to maintain a consistent shelter type in the area. By the end of Phase 2 all existing shelters in this zone will be replaced with the exception of two shelters on National Circuit near Kings Avenue, one special shelter on Sydney Avenue, one shelter on Empire Circuit and those existing shelters on NCA land and roads within the Parliamentary Zone.



### ***Town Centres***

At the completion of the project, it is proposed that, in all Town centres, virtually all concrete shelters will be replaced with new shelters.

#### **- Belconnen Town Centre**

There is only one concrete shelter in the Belconnen Town Centre. During Phase 1 five new shelters were constructed in the Belconnen Town Centre. Phase 2 and 3 shall see the construction of five more new shelters, including the replacement of the single existing concrete bunker in Phase 3. Therefore by the end of Phase 3 all shelters in Belconnen Town Centre will be the new structure type.

#### **- Woden Town Centre**

There are four existing shelters in the Woden Town Centre. One existing shelter was relocated in Phase 1. Another two shelters will also be replaced in Phase 2 and 3, leaving only one special shelter on Corrina Street in the town centre. Apart from replacing the existing shelters three shelters will be constructed at new sites within the Town Centre. At the completion of the project there will be no concrete bunkers in the Woden town centre.

#### **- Tuggeranong Town Centre**

Other than the bus interchange there is only one existing bus shelter (concrete structure).

In Phase 1, five new shelters on sites currently without shelters were built.

Phase 2 and 3 shall see the addition of five more shelters including the replacement of the existing concrete bunker within the Tuggeranong Town Centre.

At the completion of Phase 3 all sites within the Tuggeranong town centre will be of the new structure type.

#### **- Gungahlin Town Centre**

Gungahlin Town Centre did not have any existing concrete shelters prior to the commencement of the Adshel contract. One advertising shelter was built in Gungahlin Town Centre as part of Phase 1. Phase 2 and 3 will see the addition of four more advertising and non advertising shelters within the Gungahlin Town Centre.

### ***Group Centres***

In general non advertising shelters have been proposed for Group Centres throughout the ACT where they are justified. Phase 2 and 3 will see the construction of 27 of these sites.

## **2.3.2 Transport Corridors**

Transport corridors are the road links between major centres of activity and are generally arterial roads carrying high bus and general traffic volumes.

### ***Northbourne Ave***

This is a major route for entry to and exit from the City. There are a number of concrete “bunker” shelters along Northbourne Ave. Under the project it is proposed that all shelters along Northbourne



Ave will be replaced with the new shelter type. Furthermore several new shelters will be constructed at stops along this busy route which do not currently have a shelter.

#### ***Drakeford Dr***

There are two existing concrete shelters on Drakeford Dr.

In Phase 1 no new shelters were built.

In Phase 2 one new shelter on a site currently without a shelter is proposed.

In Phase 3, two new shelters are proposed, one of which will replace the existing concrete shelter in Kambah. Very few shelters are proposed along Drakeford Dr due to the low usage by passengers.

At the completion of the project only one concrete shelter will remain although due to the low numbers of new shelters it is not deemed important to replace this shelter with the new type.

#### ***Athllon Dr***

There are five existing concrete shelters on Athllon Dr.

In Phase 1 no new shelters were built.

In Phase 2 and 3, five new shelters are proposed. Four of these shelters will replace existing concrete shelters along Athllon Dr. There is currently no justification for replacing the remaining concrete shelter along this route.

#### ***Canberra Ave***

There are two existing concrete shelters on Canberra Ave.

In Phase 1 two new shelters have been built in Forrest.

In Phase 2, a further two more new shelters are proposed on Canberra Ave in Kingston.

At the completion of Phase 2 there will be two concrete shelters and four shelters of the new structure type.

The shelters are located in pairs spread a minimum of 900m apart along Canberra Ave with the two concrete bunkers located in the industrial area of Fyshwick.

#### ***Southern Cross Drive***

At the commencement of the contract with Adshel there were six existing shelters along Southern Cross Drive.

In Phase 1 one new shelter was constructed at Holt (near the Kippax Centre)

Phase 2 does not propose any new shelters along this route.

In Phase 3 there are five proposed shelters to replace four existing concrete bunkers.

At the completion of Phase 3 there will be one remaining concrete bunker in Florey.



## 3. Phasing of Shelter Construction

### 3.1 General

Construction of the 241 bus shelters is being phased over a 3-year period in three phases:

- » Phase 1 completed in March 2008 involved the construction of shelters on 53 bus stops, which currently do not have shelters.
- » Phase 2 to be completed by mid 2009 involves the construction of 98 new Adshel shelters. Any sites flagged to receive a new shelter although they already have a shelter will have this existing shelter relocated to a secondary site within the ACT. Phase 2 will result in a net benefit of 98 shelters on sites currently without shelters.
- » Phase 3 to be completed by the end of 2009 involves the construction of shelters on 90 new Adshel shelters. Any sites flagged to receive a new shelter although they already have a shelter will have this existing shelter relocated to a secondary site within the ACT. Phase 3 will result in a net benefit of 90 shelters on sites currently without shelters.

### 3.2 Phase 1

Phase 1 works consisted of:

- » 35 new advertising bus shelters
- » 18 new non advertising bus shelters
- » Relocation of two existing shelters to sites previously without shelters.

Phase 1 aimed to provide a variety of locations with new bus shelters while achieving a large commercial exposure at the start of the project.

The Phase 1 works were therefore concentrated on the city centre, inner north, inner south in the vicinity of Barton and the high-density areas of Woden, Belconnen and Tuggeranong Town Centres.

To make the project commercially viable from the start, Phase 1 had a ratio of approximately 2:1 advertising shelters to non-advertising shelters, which was in accordance with the contract.

All bus stops erected in Phase 1 of the project were evaluated against the criteria developed by Roads ACT and ACTPLA (refer Appendix A) and were found to comply with at least one of the criteria listed. Furthermore each shelter passed ACTPLA's approval rating process.

### 3.3 Phase 2

Phase 2 works will consist of:

- » 52 new advertising bus shelters;
- » 46 new non advertising bus shelters (the location of these shelters has not yet been determined);
- » Relocation of approximately 29 existing shelters to sites currently without shelters.

Phase 2 works are concentrated in the employment hub of Barton, City/inner north area, in particular on Northbourne Ave and to a lesser degree on the suburban areas of Belconnen, Woden and Gungahlin.



All sites to have a shelter erected in Phase 2 of the project have been evaluated against the criteria developed by Roads ACT and ACTPLA (refer Appendix A) and have been found to comply with at least one of the criteria listed. The justification for each shelter in Phase 2 is included in the shelter details in Appendix B.

### **3.4 Phase 3**

Phase 3 works will consist of:

- » 46 new advertising bus shelters;
- » 44 new non advertising bus shelters (the location of these shelters has not yet been determined);
- » Relocation of approximately 44 existing shelters to sites currently without shelters.

Phase 3 concentrates heavily on suburban areas throughout Canberra.

All sites to be erected in Phase 3 have been evaluated against the criteria developed by Roads ACT and ACTPLA (refer to Appendix A) and have been found to comply with at least one of the criteria listed. The justification for each shelter in Phase 3 is included in the shelter details in Appendix B.



## 4. Shelter Design

All new shelters will be of the ADSHEL EVO Mk II type. Refer to Appendix C for plans and photographs of the proposed structures.

It is proposed that a number of existing shelters (mainly of the concrete bunker type) will be relocated to allow for advertising shelters to be erected on these sites. Sites on which existing shelters will be relocated are shown in the drawings in Appendix D.



## 5. Advertising

Any advertising on bus shelters erected under this contract will conform to the signage requirements outlined in the Authority's ACT Bus and Taxi Shelter Signage Master Plan, 19 April 2006.

### 5.1 Size and Location of Advertising Panels

Advertising panels shall be located only on bus shelters and shall have maximum dimensions of 1.8m by 1.2m except in Designated Areas where panel dimensions shall be in accordance with the National Capital Plan. Advertising panels may be dual sided but shall only be located at the departure end of bus shelters.

### 5.2 Movable Advertising Panels

This plan allows for movable advertising panels of the dimensions listed above in all localities.

### 5.3 Lighting of Advertising Panels

All advertising panels will be lit at night using the street light network and light overspill will illuminate the surrounds and internal space of the structure.

### 5.4 Advertising Content

All advertising as a minimum must comply with the Advertising Standard adopted by the Australian Association of National Advertisers (AANA) (the Advertising Standard).

Advertisements of and/or in relation to the products and matters that are listed below shall be prohibited:

- a) Advertisements for cigarettes or tobacco products,
- b) Political advertisements,
- c) Religious advertisements,
- d) Advertisements that are false or misleading,
- e) Advertisements which promote unlawful or illegal goods, services or activities or which are otherwise unlawful,
- f) Advertising material likely to offend against community taste and standards,
- g) Advertising material determined by the Territory as offensive, obscene or causing damage,
- h) Other matters which may be determined by the Territory from time to time and notified to the Contractor in writing.





## 5. Advertising

Any advertising on bus shelters erected under this contract will conform to the signage requirements outlined in the Authority's ACT Bus and Taxi Shelter Signage Master Plan, 19 April 2006.

### 5.1 Size and Location of Advertising Panels

Advertising panels shall be located only on bus shelters and shall have maximum dimensions of 1.8m by 1.2m except in Designated Areas where panel dimensions shall be in accordance with the National Capital Plan. Advertising panels may be dual sided but shall only be located at the departure end of bus shelters.

### 5.2 Movable Advertising Panels

This plan allows for movable advertising panels of the dimensions listed above in all localities.

### 5.3 Lighting of Advertising Panels

All advertising panels will be lit at night using the street light network and light overspill will illuminate the surrounds and internal space of the structure.

### 5.4 Advertising Content

All advertising as a minimum must comply with the Advertising Standard adopted by the Australian Association of National Advertisers (AANA) (the Advertising Standard).

Advertisements of and/or in relation to the products and matters that are listed below shall be prohibited:

- a) Advertisements for cigarettes or tobacco products,
- b) Political advertisements,
- c) Religious advertisements,
- d) Advertisements that are false or misleading,
- e) Advertisements which promote unlawful or illegal goods, services or activities or which are otherwise unlawful,
- f) Advertising material likely to offend against community taste and standards,
- g) Advertising material determined by the Territory as offensive, obscene or causing damage,
- h) Other matters which may be determined by the Territory from time to time and notified to the Contractor in writing.



## 5. Advertising

Any advertising on bus shelters erected under this contract will conform to the signage requirements outlined in the Authority's ACT Bus and Taxi Shelter Signage Master Plan, 19 April 2006.

### 5.1 Size and Location of Advertising Panels

Advertising panels shall be located only on bus shelters and shall have maximum dimensions of 1.8m by 1.2m except in Designated Areas where panel dimensions shall be in accordance with the National Capital Plan. Advertising panels may be dual sided but shall only be located at the departure end of bus shelters.

### 5.2 Movable Advertising Panels

This plan allows for movable advertising panels of the dimensions listed above in all localities.

### 5.3 Lighting of Advertising Panels

All advertising panels will be lit at night using the street light network and light overspill will illuminate the surrounds and internal space of the structure.

### 5.4 Advertising Content

All advertising as a minimum must comply with the Advertising Standard adopted by the Australian Association of National Advertisers (AANA) (the Advertising Standard).

Advertisements of and/or in relation to the products and matters that are listed below shall be prohibited:

- a) Advertisements for cigarettes or tobacco products,
- b) Political advertisements,
- c) Religious advertisements,
- d) Advertisements that are false or misleading,
- e) Advertisements which promote unlawful or illegal goods, services or activities or which are otherwise unlawful,
- f) Advertising material likely to offend against community taste and standards,
- g) Advertising material determined by the Territory as offensive, obscene or causing damage,
- h) Other matters which may be determined by the Territory from time to time and notified to the Contractor in writing.



## 5. Advertising

Any advertising on bus shelters erected under this contract will conform to the signage requirements outlined in the Authority's ACT Bus and Taxi Shelter Signage Master Plan, 19 April 2006.

### 5.1 Size and Location of Advertising Panels

Advertising panels shall be located only on bus shelters and shall have maximum dimensions of 1.8m by 1.2m except in Designated Areas where panel dimensions shall be in accordance with the National Capital Plan. Advertising panels may be dual sided but shall only be located at the departure end of bus shelters.

### 5.2 Movable Advertising Panels

This plan allows for movable advertising panels of the dimensions listed above in all localities.

### 5.3 Lighting of Advertising Panels

All advertising panels will be lit at night using the street light network and light overspill will illuminate the surrounds and internal space of the structure.

### 5.4 Advertising Content

All advertising as a minimum must comply with the Advertising Standard adopted by the Australian Association of National Advertisers (AANA) (the Advertising Standard).

Advertisements of and/or in relation to the products and matters that are listed below shall be prohibited:

- a) Advertisements for cigarettes or tobacco products,
- b) Political advertisements,
- c) Religious advertisements,
- d) Advertisements that are false or misleading,
- e) Advertisements which promote unlawful or illegal goods, services or activities or which are otherwise unlawful,
- f) Advertising material likely to offend against community taste and standards,
- g) Advertising material determined by the Territory as offensive, obscene or causing damage,
- h) Other matters which may be determined by the Territory from time to time and notified to the Contractor in writing.



Appendix A  
Bus Shelter Site Evaluation Criteria



## Demand Criteria\* for the Installation of New Bus Shelters

Before granting of an endorsement for a new bus shelter not replacing an existing bus shelter, the Department of Territory and Municipal Services must be satisfied that one or more of the following demand criteria have been met.

The site of the proposed bus shelter:

1. Is an existing bus stop with an average of 8 or more people using the stop per hour during peak periods;
2. Is located at a local centre;
3. Is within 200m walking distance of aged care accommodation;
4. Is within 400m walking distance of a primary school, high school, college or university;
5. Is located within walking distance of a significant node of employment outside Civic, town or group centres;
6. Will service a tourist facility outside Civic, town or group centres;
7. Is located within walking distance of a significant community facility;
8. Will service increased density development.
9. In exceptional circumstances approval may be given by the Department for the location of shelters on sites not complying with the above criteria but which are considered necessary and justifiable for meeting specific or special community needs.

Bus Shelters with advertising shall not be randomly located to respond to visibility and commercial considerations. They shall only be approved where there is a clear need by the community or consistency along a road or within a town centre can be demonstrated.

\*Roads ACT in conjunction with ACTION and ACTPLA will review these criteria during the course of this project and revise them as necessary based on the experience gained in applying the criteria in practise.



Appendix B  
**Bus Shelter Justification**

## PHASE 2 SHELTER JUSTIFICATION

Phase	Ad	Non-Ad	Existing Shelter	Relocation	RDG Drg #	Bus Stop Number	Action Map #	Location	Region	Request Type	GHD Comments
2		1	None		2	0002	66	Athllon Dr.northbound north of Learmonth Dr	Tuggeranong	action request	To be postponed due to Athllon Dr Duplication (08/09)
2		1	None			1001		Drumsten st	Isabella Plains	Public request	Within 400m of School
2		1	None			1002		Drumsten st	Isabella Plains	Public request	Within 400m of School
2		1	None			1008		Ellerston Ave	Isabella Plains	Public request	Within 400m of school
2			None	1		1028		Duggan St, Calwell	Calwell	public request	Volume check reveals reasonable volumes 6 passengers in peak hour
2	1		None			1059		Soward Way	Greenway	action request	At local Centre
2		1	None			1067		Anketell st	Greenway	action request	Walk to employment node/at local centre
2		1	None			1068		Anketell st	Greenway	action request	Walk to employment node/at local centre
2			None	1		1100		Scantlebury Cres	Theodore	public request	Peak hour volume
2			None	1		1168		Duggan St, Calwell	Calwell	public request	Volume check reveals reasonable volumes 6 passengers in peak hour
2			None	1		1191		Knoke	Gordon	action request	Within 400m of school
2			None	1		1208		Tom roberts ave	Banks	Public request	Within 400m of school
2		1	None			1274		Barritt st	Kambah	action request	Peak hour volume
2		1	None			1277		Barritt st	Kambah	action request	Peak hour volume
2		1	None			1317		Garratt st	Wanniassa	Public request	Within 200m of Aged care facility
2		1	None			1318		Garratt st	Wanniassa	Public request	Within 200m of Aged care facility
2		1	None			1345		Marconi cres	Kambah	Public request	Within 400m of school
2		1	None			1386		Longmore	Wanniassa	action request	At local centre
2		1	None			1429		Sternberg	Wanniassa	action request	Within 400m of school
2			None	1		1445		Charleston Street	Monash	public request	Peak hour volume
2			None	1		1538		Norriss	Chisholm	action request	Within 400m of school
2		1	None			2009		Throssel st	Curtin	Public request	Peak hour volume
2		1	None			2023		Throssel st	Curtin	Public request	Walk to community facility
2	1		1		35	2032	80	Melrose Dr., Lyons, Adjacent to The Church of Christ	Woden		Walk to employment node/community facility
2	1		None			2093		W/S Yamba Dr Outside Eddison Park	Woden	Adshel request	Within 400m of School
2			None	1		2146		Hindmarsh Drive, Rivett	Weston	public request	Peak hour volume
2			None	1		2198		Hilder Street,	Weston	Relocation list	Within 400m of school
2		1	None			2219		Gawler, Deakin	Deakin	action request	Within 400m of school
2	1		1		48	2254	48	National Cct., Barton, northbound near Sydney Ave.	Barton		Walk to employment node
2	1		1		49	2255	48	National Cct., Barton, southbound near Sydney Ave.	Barton		Walk to employment node
2	1		1			2257		National Cct., Barton, near Brisbane Ave.	Barton		Walk to employment node
2			None	1		2286		Macgregor	Deakin	Adshel Proposed	At local centre
2			None	1		2289		Yambina,	Warramanga	Relocation list	Within 400m of school
2	1	1	1			2327		E/S Franklin St N/O Flinders St	Manuka	DOUBLE SHELTER	At Local Centre
2	1		None			2378		E/S Yamba Dr Opp Eddison Park	Woden	Adshel request	Within 400m of School
2			None	1		2384		Nyrang st	Narrabundah		Walk to community facility
2	1		1			2388		S/S Newcastle St W/O Isa St	Fyshwick	Adshel request	Industrial Area-Walk to employment node
2			None	1		2394		Mulley st	Holder	public request	Walk to community facility
2	1		1			2446		Brisbane Ave	Barton		Walk to employment node
2			None	1		2571		Jerrabomberra Ave	Narrabundah	Adshel Proposed	Within 400m of school
2	1		1		61	2602	80	Hindmarsh Dr., Phillip, eastbound west of Yamba Dr.	Woden		Within 400m of School

## PHASE 2 SHELTER JUSTIFICATION

Phase	Ad	Non-Ad	Existing Shelter	Relocation	RDG Drg #	Bus Stop Number	Action Map #	Location	Region	Request Type	GHD Comments
2	1		1		62	2603	80	Hindmarsh Dr., Phillip, westbound west of Yamba Dr.	Woden		Within 400m of School
2	1		1		64	2610	79	Athllon Dr., Pearce northbound north of Mawson Dr	Woden		At Local Centre
2	1		1		67	2652	95	Athllon Dr., Torrens northbound north of Beasley St	Woden		Within 400m of School
2	1		None		69	2678	84	Canberra Ave., Narrabundah, southbound south of Nyrang	Narrabundah		At Local Centre
2	1		None		71	2680	84	Canberra Ave., Narrabundah, northbound north of Nyrang	Narrabundah		At Local Centre
2		1	None			2686		Wormald St	Symonston	Public request	Walk to community facility (eye hospital)
2	1		None			2919		W/S Ipswich St N/O Canberra Ave	Fyshwick	Adshel request	Industrial Area-Walk to employment node
2	1		None		86	3036	10	London Cct. Northbound north of Edinburgh	City		Walk to employment node (low patronage ACTION)
2			None	1		3076		W/S Blamey Cr S/O Chauvel St	Campbell	public request	At local centre/within 400m of school
2			None	1		3234		Gooreen St,	Braddon	Relocation list	Within 400m of school
2			None	1		3247		S/S Knox St. Opp Ovals	Watson	Adshel Proposed	At local centre/within 400m of school
2	1		None			3262		N/S National Cct E/O Canberra Ave	Barton	Adshel request	Within 400m of School
2	1		1			3263		S/S National Cct E/O Canberra Ave	Barton	Adshel request	Within 400m of School
2		1	None			3385		E/S Fawknor st N/O Elouera St	Braddon	public request	Within 400m of school/walk to community facility
2			None	1		3391		N/S Knox St. Outside Ovals	Watson	action request	Within 400m of school
2			None	1		3428		S/S Aspinall St. E/O Stirling Ave	Watson	action request	Walk to community facility/at tourist site
2			None	1		3434		Ginninderra Dr,	Dunlop	Relocation list	Peak hour volume, 7 passengers in peak hour
2			None	1		3443		Lance Hill,	Dunlop	Relocation list	Peak hour volume, 6 passengers in peak hour
2			None	1		4010		Baldwin Dr.	Kaleen	Adshel Proposed	Within 400m of school
2		1	None			4031		Maribyrnong Avenue	Kaleen	public request	Within 400m of school
2		1	None			4037		Maribyrnong,	Kaleen	Relocation list	At local centre
2			None	1		4067		John Cleland	Florey	action request	Within 400m of school
2		1	None			4168		Alfred Hill Dr	Melba	public request	Volume Check reveals reasonable volumes 7 passengers in Peak hour
2		1	None			4170		Alpen St	Melba	public request	Peak hour volume
2			None	1		4315		Beaurepaire Crm,	Holt	Relocation list	At local centre
2	1		None			4527		E/S Barry Drive W/O Daley Rd	Acton	Adshel request	Within 400m of ANU
2	1		1		124	4530	10	Marcus Clarke St. northbound south of Barry Dr	City		At Local Centre
2	1		1		126	4551	12	Northbourne Ave. Dickson southbound south of Antill	North Canberra		At Local Centre
2	1		1		127	4552	12	Northbourne Ave. Lyneham northbound south of Mouat St	North Canberra		At Local Centre
2	1		1		128	4553	12	Northbourne Ave. Dickson southbound near Morphett St	North Canberra		At local centre/within 400m of school
2	1		1		129	4554	12	Northbourne Ave. Lyneham northbound near Murdoch St	North Canberra		Within 400m of School
2	1		1		130	4555	37	Northbourne Ave. Dickson southbound adjacent Karuah St	North Canberra		Service tourist facility



## PHASE 2 SHELTER JUSTIFICATION

Phase	Ad	Non-Ad	Existing Shelter	Relocation	RDG Drg #	Bus Stop Number	Action Map #	Location	Region	Request Type	GHD Comments
2	1		1		132	4557	6	Northbourne Ave. Braddon southbound near Wakefield Ave	North Canberra		Walk to employment node
2	1		1		133	4558	6	Northbourne Ave. Turner northbound near Macarthur Ave	North Canberra		Walk to employment node
2	1		1		134	4559	6	Northbourne Ave.Braddon southbound near Ipima St	North Canberra		Walk to employment node/within 400m of school
2	1		1		135	4560	6	Northbourne Ave. Turner northbound north of Condamine St	North Canberra		Walk to employment node/within 400m of school
2	1		1		136	4561	6	Northbourne Ave. Braddon southbound south of Ipima St	North Canberra		New route focuses on Northborne
2	1		1		137	4562	6	Northbourne Ave. Turner northbound south of Condamine St	North Canberra		New route focuses on Northborne
2	1		1		138	4563	6	Northbourne Ave. Braddon Southbound south of Girrahween St	North Canberra		Walk to employment node/high density development
2	1		None		139	4564	6	Northbourne Ave. Turner northbound south of Masson St	North Canberra		Walk to employment node/high density development
2	1		1			4566		Northbourne Ave	Turner		Walk to employment/service high density area
2		1	None			4583		N/S Antill St E/O Northbourne Ave	Dickson	Adshel Proposed	At local centre/walk to employment node
2	1		None			4604		Northbourne Ave. Lyneham northbound North of Mouat St	North Canberra		Walk to community facility
2			None	1		4640		Templeton St.	Cook	action request	Within 400m of school
2		1	None			4696		Wanganeen St.	Ngunnawal	action request	Within 400m of school
2		1	None			4697		Wanganeen st	Ngunnawal	action request	Within 400m of school
2		1	None			4702		Unaipon Avenue	Ngunnawal	public request	Within 400m of school
2		1	None			4704		Len Waters St	Ngunnawal	public request	Peak hour volume
2		1	None			4708		Mirrabei Drive	Ngunnawal	public request	Within 400m of school
2		1	None			4709		Mirrabei Drive	Ngunnawal	public request	Within 400m of school
2		1	None			4713		Mirrabei dr	Amaroo	Public request	Peak hour volume
2		1	None			4714		Shoalhaven	Amaroo	action request	Peak hour volume
2		1	None			4715		Shoalhaven	Amaroo	action request	Peak hour volume
2	1		1			4727		S/S Gundaroo Dr W/O Gunghalin Dr	Palmerston	Adshel request	Peak hour volume
2		1	None			4730		Anne Clark Avenue	Nicholls	public request	Peak hour volume
2	1		None			4749		Northbourne Ave, intersection Phillip Avenue	North Canberra		At Tourist facility
2		1	None			4780		Kosciuszko Ave	Palmerston	action request	Within 400m of school
2		1	None			4784		Kosciuszko Ave	Palmerston	Public request	Within 200m of Aged care facility
2		1	None			4785		Kosciuszko Ave (near Bimberi Cres/Alm Close underpass)	Palmerston	public request	Peak hour volume
2		1	None			4792		William Slim Dr	Giralang	action request	Peak hour volume
2	1		1			4803		W/S Haydon Drive N/O Belconnen Way	Bruce	Adshel request	At Hospital
2		1	None			4829		Kosciuszko Ave	Palmerston	action request	Within 400m of school
2			None	1		4899		Kerrigan St.	Dunlop	action request	Fast Developing area
2			None	1		5004		Baldwin Dr.	Kaleen	action request	Within 400m of school/walk to community facility
2			None	1		5026		Kerrigan St.	Dunlop	action request	Fast Developing area
2	1		1			5054		S/S Gundaroo Dr W/O Nundurr Rd	Palmerston	Adshel request	Peak hour volume
2		1	None			5072		Kelleway	Nicholls	action request	Within 400m of school/at local centre

## PHASE 2 SHELTER JUSTIFICATION

Phase	Ad	Non-Ad	Existing Shelter	Relocation	RDG Drg #	Bus Stop Number	Action Map #	Location	Region	Request Type	GHD Comments
2	1		None			5084		S/S The Valley Ave E/O Gunghalin Dr	Gungahlin	Adshel request	Within 400m of school
2		1	None			5085		Gozzard St	Gungahlin	public request	At local centre
2			None	1		5102		Kerrigan St.	Dunlop	public request	Fast developing area
2		1	None			6000		Burdekin St.	Amaroo	action request	Within 400m of school
2			None	1		6046		Kerrigan St.	Dunlop	action request	Peak hour volume

### Totals

<b>Ad</b>	42
<b>Non-Ad</b>	42
<b>Relocations Required</b>	29
<b>Relocations Provided</b>	30

### PHASE 3 SHELTER JUSTIFICATION

Phase	Ad	Non-Ad	Existing Shelter	Relocation	RDG Drg #	Bus Stop Number	Action Map #	Location	Region	Request Type	Justification
3		1	1			1017		Webber cct, Calwell Centre	Calwell		At local centre
3	1		None			1061		N/S Soward Way E/O Anketell St	Tuggeranong	Adshel Requested	At local centre/within 400m of school
3		1	None			1080		Outtrim Ave Calwell	Tuggeranong	public request	To be checked for justification
3		1	1			1147		Chisholm Centre, Benham St.	Group Shopping Centre		At local centre
3		1	1			1148		Benham st, Chisholm Centre	Chisholm		At local centre
3		1	1			1172		Comrie st, Erindale Centre	Erindale		At local centre
3		1	1			1173		Comrie st, Erindale Centre	Erindale		At local centre
3		1	None		16	1245	55	Tharwa Dr., Conder northbound north of Mentone	Tuggeranong	action request	To be postponed due to Tharwa Dr Duplication (2008/09). This shelter has been knocked over
3		1	None			1275		Barritt St, Kambah	Tuggeranong	Existing Council Request	Peak hour volume
3		1	None			1276		Barritt St, Kambah	Tuggeranong	Existing Council Request	Peak hour volume
3	1		1		19	1341	75	Drakeford Dr., Kambah northbound north of Boddington	Tuggeranong		At local centre
3		1	1			1343		marconi cres	Kambah		At local centre
3		1	1			1344		marconi cres	Kambah		At local centre
3	1					1371		Drakeford Dr., Greenway northbound north of Taverner	Tuggeranong	Existing Council Request	Peak hour volume
3	1		1			1375		Athlon Dr	Tuggeranong		At local centre
3	1		1		33	2002	80	Launceston St. westbound near Furzer St	Woden		Walk to employment node/walk to community facility
3	1		None		34	2031	80	Launceston St. eastbound near Furzer St	Woden		Walk to employment node/walk to community facility
3	1		1		37	2044	82	Southlands Shopping Centre, Heard St., Mawson	Group Shopping Centres		At local centre
3	1		None			2084		Melrose drive, Phillip	Woden		Walk to employment node
3	1		None			2088		N/S Botany St E/O Melrose Dr	Woden	Adshel request	Industrial Area-Walk to employment node
3			None	1		2163		Perry dr, Chapman	Weston	public request	Within 400m of school
3			None	1		2189		Mclnnes	Weston	Adshel Proposed	Within 200m of Aged Care
3		1	1			2195		N/S Hilder St S/O Mclnnes St	Weston	Adshel Proposed	Within 400m of school
3	1		1			2200		Namatjira Dr	Weston	Adshel Requested	Within 400m of Old Persons home - not on new action bus route???
2		1	1			2205		Cooleman Ct, Parkinson St., Weston e	Weston		At local centre
3	1		1		46	2206	98	Cooleman Ct, Parkinson St., Weston westbound	Group Shopping Centres		At local centre
3	1		1			2223		W/S Hopetoun Circuit N/O Grose St	Deakin	Adshel request	At local centre
3	1		None			2233		Wentworth Ave	Kingston	public request	Peak hour volume
3	1		None			2278		W/S Kent St S/O Strickland Cres	Deakin	Adshel Requested	Walk to Hospital/Within 400m of school
3		1	1			2285		N/S Macgregor St E/O De Chair St	Deakin	Adshel Proposed	Within 200m of Aged Care
3	1		None			2291		E/S Kent St S/O Strickland Cres	Deakin	Adshel Requested	Walk to Hospital/Within 400m of school
3	1		1		54	2304	57	Strickland Cres., Deakin eastbound Adjacent to John James Hospital	Deakin		Walk to community facility
3	1		1		55	2305	57	Strickland Cres., Deakin westbound adjacent to John James Hospital	Deakin		Walk to community facility

### PHASE 3 SHELTER JUSTIFICATION

Phase	Ad	Non-Ad	Existing Shelter	Relocation	RDG Drg #	Bus Stop Number	Action Map #	Location	Region	Request Type	Justification
3			None	1		2313		Melbourne Ave	Forrest	Adshel Proposed	Within 400m of school
3	1		None			2373		Wentworth Ave	Kingston	public request	Peak hour volume
3	1		1			2382		Yamba Drive, Phillip	Woden		Walk to community facility
3	1		None			2387		E/S Ipswich St N/O Canberra Ave	Fyshwick	Adshel Requested	Industrial area-walk to employment node
3			None	1		2549		Nyrang st	Narrabundah		Walk to community facility
3	1		None			2598		S/S Giles St at Kingston Shops	Kingston	Adshel Requested	At local centre
3	1		1			2609		E/S Athllon Dr S/O Beasley St	Woden		At local centre/within 400m of school
3	1		None			2622		E/S Wollongong St N/O Newcastle St	Fyshwick	Adshel Requested	Industrial area-walk to employment node
3	1		None			2690		Namatjira Dr	Weston	Adshel Requested	Within 400m of Old Persons home - not on new action bus route???
3	1		1			3025		N/S Carruthers St W/O Denison St	Curtin	Adshel Requested	Within 200m of Old persons home
3	1		1		88	3042	10	Allinga St.westbound west of West Row	City		At Local Centre
3	1		1			3055		Ainslie Ave, Reid	City		Within 400m of School
3	1		1			3056		Ainslie Ave, Reid	City		Within 400m of School
3	1		1			3164		Cowper st, adjacent to swimming pool	Dickson		At local centre, busy stop
3			None	1		3210		Officer Cres	Ainslie	Adshel Proposed	Within 400m of School
3	1		1			3380		Wattle St Outside Shops Lyneham	Lyneham	Adshel Requested	At local centre/within 400m of school
3	1		None			3398		Wattle St Outside Shops Lyneham	Lyneham	Adshel Requested	At local centre/within 400m of school
3	1		None		101	3441	5	College St. eastbound outside the swimming centre	Belconnen		Walk to community centre
3	1		None		102	3442	5	College St.westbound opposite the swimming centre	Belconnen		Walk to community centre
3	1		None			3450		London Cct, City	North Canberra	Stop Relocated (mario sallechchia)	At local centre
3		1	None			4036		Maribyrnong Avenue	Kaleen	Adshel Proposed	At local centre
3		1	1			4065		John Cleland	Florey	Adshel Proposed	Within 400m of school
3	1		1			4146	5	Emu Bank Eastbound outside Ginninderra College	Belconnen		within 400m of school
3	2		None		108	4183	5	Lathlain St. northbound south of Cohen	Belconnen	action request	Roads ACT request 2 shelters at site on 20/2/07. Delayed until New intersection built
3	1		None		109	4184	5	Lathlain St. southbound south of Cohen	Belconnen	action request	Delayed until new intersection Built
3	1		None			4271		Coulter drive, macquarie	Belconnen	Adshel request	Peak hour volume
3	1		1			4295		Belconnen way, Scullin	Belconnen		Walk to Community Facility
3	1		1			4327		Southern Cross drive, Macgreggor	Belconnen		Within 400m of School
3	1		None			4358	27	Southern Cross Drive, Latham eastbound east of Ologhlen	Latham		within 400m of school
3	1		1			4360	27	Southern Cross Drive, Latham eastbound west of Ologhlen	Latham		within 400m of school
3	1		1			4397	27	Southern Cross Drive, Latham eastbound east of Dalley Cr	Latham		within 400m of school
3		1	None			4450		Beetaloo st Hawker	Belconnen	public request	Peak hour volume
3	1		1			4493		W/S Bindubi St S/O Belconnen Way, Macquarie	Belconnen	Adshel Requested	Within 400m of school
3	1		1			4494		E/S Bindubi St S/O Belconnen Way, Macquarie	Belconnen	Adshel Requested	Within 400m of school

### PHASE 3 SHELTER JUSTIFICATION

Phase	Ad	Non-Ad	Existing Shelter	Relocation	RDG Drg #	Bus Stop Number	Action Map #	Location	Region	Request Type	Justification
3	1		None			4515		Jamison Shopping Centre, Bowman St., Macquarie	Macquarie	Existing Council Request	At local centre
3	1		None			4516		Jamison Shopping Centre, Bowman St., Macquarie	Macquarie	Existing Council Request	At local centre
3	1		1			4517	31	Jamison Shopping Centre, Bowman St., Macquarie	Macquarie	Existing Council Request	At local centre
3	1		1			4528		W/S Barry Drive W/O Daley Rd	Acton	Adshel request	Within 400m of ANU
3	1		1			4531		N/S Alinga St W/O West Row	City		At local centre
3	1		1			4547		E/S Mouat St outside Hockey Centre	Lyneham	Adshel Requested	Within 200m of Old persons home
3	1		None			4575		N/S Macarthur Avenue Outside school O'Connor	North Canberra		Within 400m of school
3	1		1			4584		S/S Antill St Opp Pigot St	Dickson		At local centre
3		1	1			4699		Unaipon Avenue	Ngunnawal	Adshel Proposed	Within 400m of school
3		1	None			4751		Flemington Road Adjacent to Epic Centre	North Canberra	action request	
3		1	None			4781		Kosciuszko Ave - adj to Primary School - (near Under Passes)	Palmerston		Within 400m of school
3	1		None			4793		W/S William Slim Drive N/O William Webb Dr	Giralang		Peak hour volume
3	1		1		153	4825	23	Belconnen Way, Hawker eastbound opposite Hawker Oval	Belconnen		within 400m of school
3	1		1		154	4826	23	Belconnen Way, Hawker eastbound near Petterd St	Belconnen		within 400m of school
3	1		1			5003		Southern Cross Dr E/O Ratcliffe Cres Florey	Belconnen	Adshel Requested	Within 400m of school
3		1	None			5049		Murdoch st Lyneham	Inner north	public request	Action endorsed
3		1	None			5086		Gozzard St	Gungahlin		At local centre
3		1	None			6067		Moonlight Cres Gungahlin	Gungahlin	public request	To be checked for justification
3	1		None			3451A		Akuna st, City	North Canberra	New stop (mario sallechia)	At local centre
3	1		None			3451B		Akuna st, City	North Canberra	New stop (mario sallechia)	At local centre
3		1	None			3452A		West Row	City	Roads ACT request	Roads ACT Promised

<b>Totals</b>	
<b>Ad</b>	60
<b>Non-Ad</b>	24
<b>Relocations</b>	
<b>Required</b>	44
<b>Relocations</b>	
<b>Provided</b>	5



Appendix C  
**Bus Shelter Design**

ADSHEL EVO Mk II

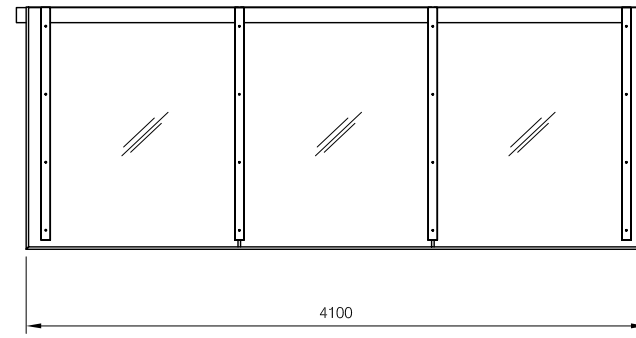

TOP VIEW

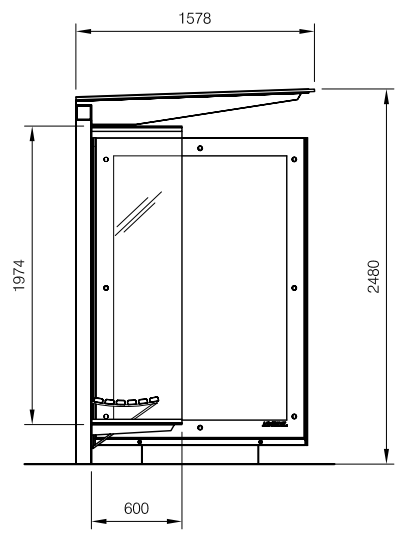

LEFT SIDE VIEW

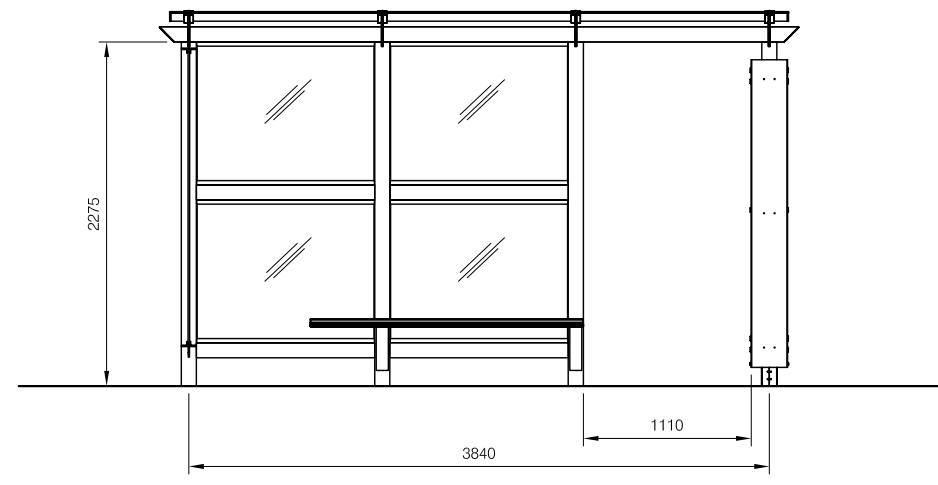

FRONT VIEW

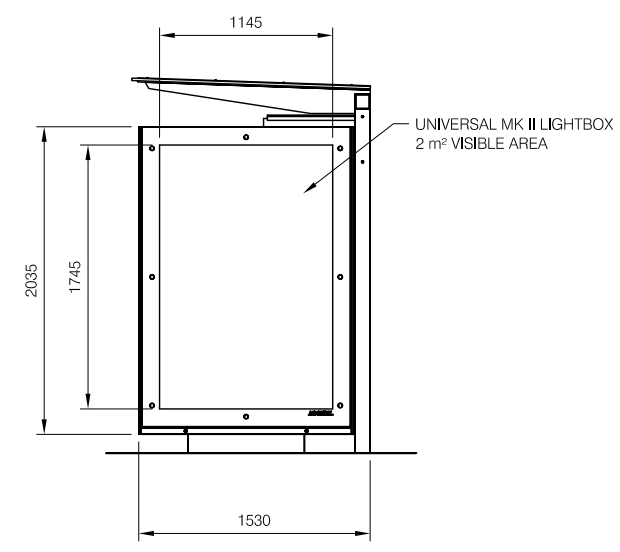

RIGHT SIDE VIEW

PROJECT: EVO MK II - AD VERSION	
TITLE: ASSEMBLY	
DRAWING #: EMKIL_A_1	SCALE: 1:50
DRAWN BY: TBK	DATE: 8/12/2005
 ADSHEL <small>COPYRIGHT ADSHEL 2004</small>	
A3	

COMPONENT DRAWING LIST			
ITEM	DWG #	DRAWING TITLE	QTY.
	EMKII_A_1	ASSEMBLY	
	EMKII_A_2	ASSEMBLY FULLBACK	
1	EMKII_A_3	UPRIGHT 1	1
2	EMKII_A_4	UPRIGHT 2	1
3	EMKII_A_5	UPRIGHT 3	1
4	EMKII_A_6	UPRIGHT 4	1
5	EMKII_A_11	TOP BEAM ASSEMBLY	1
6	EMKII_A_12	MID RAIL	6
7	EMKII_A_13	MID RAIL BRACKET	12
8	EMKII_A_14	GLAZING ADAPTOR	12
9	EMKII_A_15	SEAT BRACKET	2
10	EMKII_A_16	SEAT SLATS	6
11	EMKII_A_17	ROOF GLASS	1
12	EMKII_A_18	BACK GLASS	1
13	EMKII_A_19	WINDBREAK GLASS	1
14	EMKII_A_20	ROOF GLASS TRIM	1
	EMKII_A_21	FOOTING	1

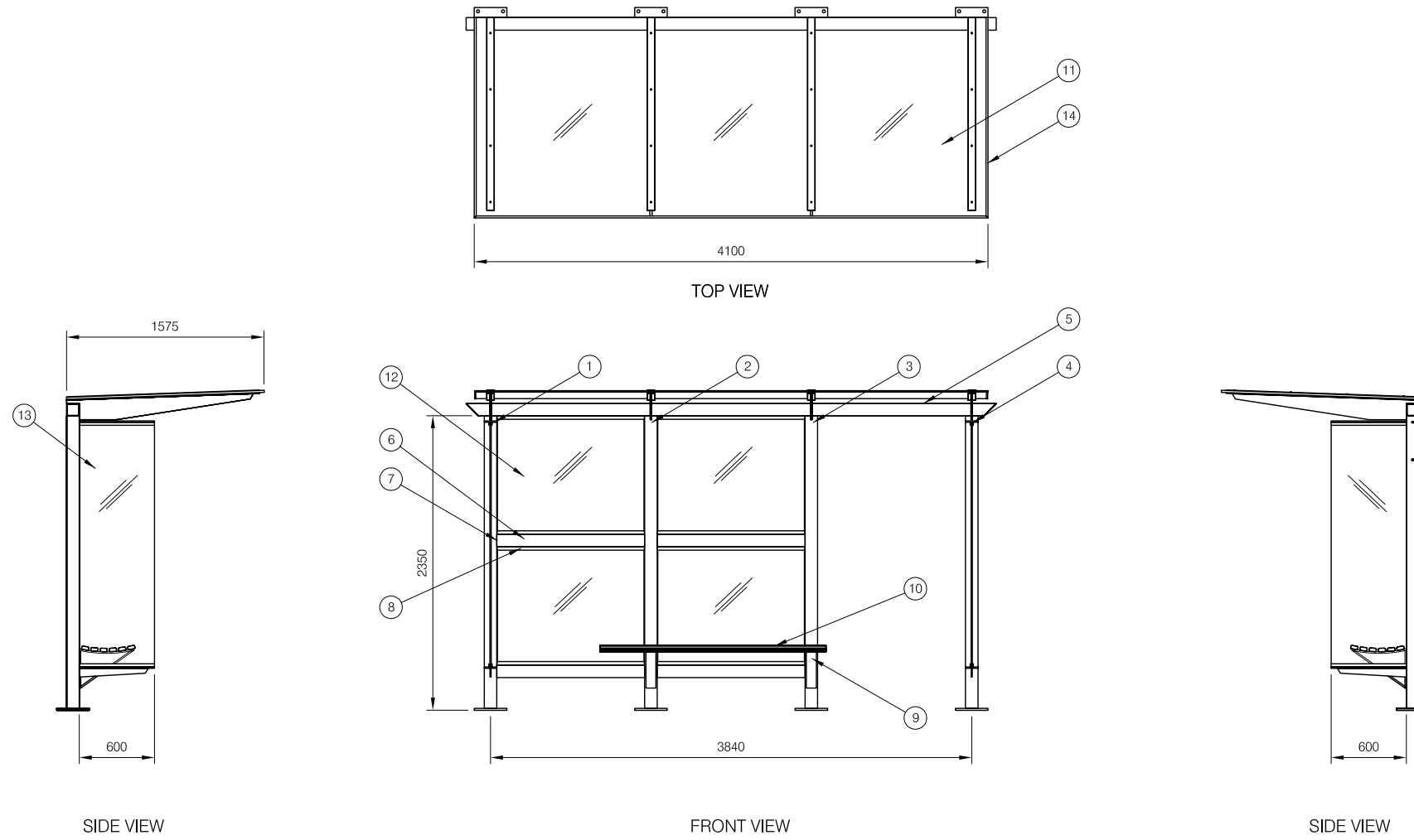

PROJECT: EVO MK II	
TITLE: ASSEMBLY	
DRAWING #: EMKII_1	SCALE: 1:50
DRAWN BY: TBK	DATE: 8/12/2005
 ADSHEL <small>COPYRIGHT ADSHEL 2004</small>	
A3	





BUS STOP  
ACTION  
11.11.10

In touch with the  
**COMMUNITY**  
ADSHEL  
[www.adshel.com.au/community](http://www.adshel.com.au/community)









Appendix D  
Bus Shelter Location Drawings



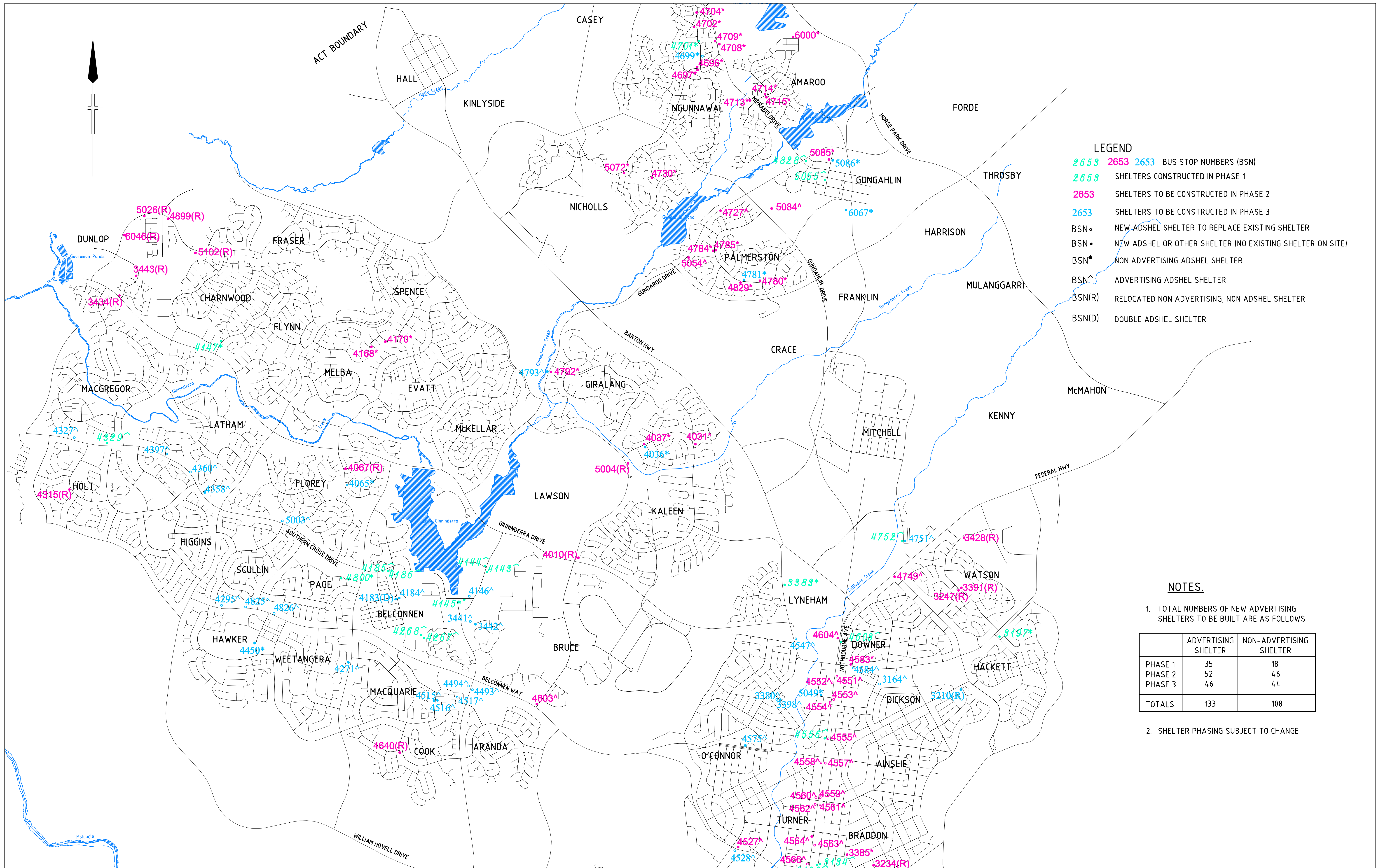

**LEGEND**

- 2653 2653 2653 BUS STOP NUMBERS (BSN)
- 2653 SHELTERS CONSTRUCTED IN PHASE 1
- 2653 SHELTERS TO BE CONSTRUCTED IN PHASE 2
- 2653 SHELTERS TO BE CONSTRUCTED IN PHASE 3
- BSN◦ NEW ADSHEL SHELTER TO REPLACE EXISTING SHELTER
- BSN• NEW ADSHEL OR OTHER SHELTER (NO EXISTING SHELTER ON SITE)
- BSN\* NON ADVERTISING ADSHEL SHELTER
- BSN◡ ADVERTISING ADSHEL SHELTER
- BSN(R) RELOCATED NON ADVERTISING, NON ADSHEL SHELTER
- BSN(D) DOUBLE ADSHEL SHELTER

**NOTES.**

1. TOTAL NUMBERS OF NEW ADVERTISING SHELTERS TO BE BUILT ARE AS FOLLOWS

	ADVERTISING SHELTER	NON-ADVERTISING SHELTER
PHASE 1	35	18
PHASE 2	52	46
PHASE 3	46	44
TOTALS	133	108

2. SHELTER PHASING SUBJECT TO CHANGE

No	Revision	Note	Drawn	Checked	Approved	Date
D	MASTER PLAN rev 3		RL	GG	PE	29.08.08
C	MASTER PLAN rev 2		RL	GG	TC	26.03.08
B	GENERAL REVISIONS		SOK			
A	PRELIMINARY		RL	GG	GG	22.02.07

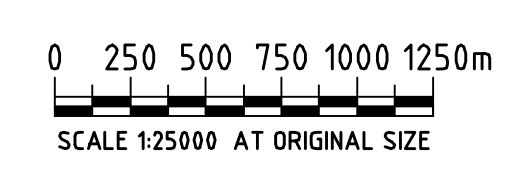

**GHD** CLIENTS | PEOPLE | PERFORMANCE

6th Floor, Belconnen Chambers  
59 Cameron Ave Belconnen ACT 2617 Australia  
PO Box 36 Belconnen ACT 2617  
T 61 2 6253 1999 F 61 2 6253 1911  
E cbrmail@ghd.com.au W www.ghd.com.au

**DO NOT SCALE**

Drawn	RL	Designed	GG
Drafting		Design	
Check		Check	
Approved			
Date			
Scale	AS SHOWN	This Drawing must not be used for Construction unless signed as Approved	

**ROADS ACT  
AD AND NON AD BUS SHELTERS IN THE ACT  
PROPOSED BUS SHELTER LOCATIONS  
SHEET 1 OF 3**

Client  
Project  
Title  
Original Size  
**A1** Drawing No: **23-12034-C001** Rev: **D**







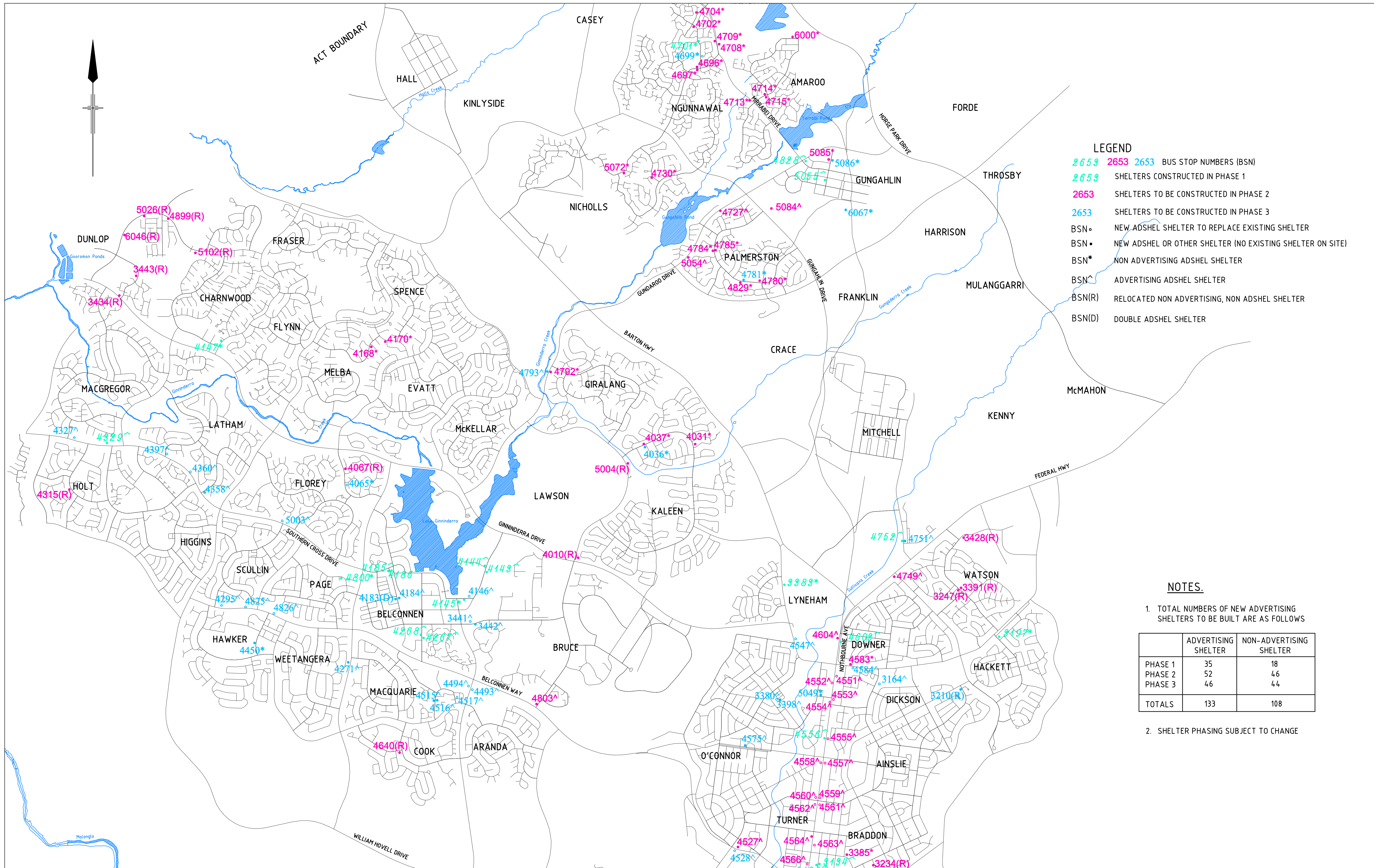

**LEGEND**

- 2653 2653 2653 BUS STOP NUMBERS (BSN)
- 2653 SHELTERS CONSTRUCTED IN PHASE 1
- 2653 SHELTERS TO BE CONSTRUCTED IN PHASE 2
- 2653 SHELTERS TO BE CONSTRUCTED IN PHASE 3
- BSN◦ NEW ADSHEL SHELTER TO REPLACE EXISTING SHELTER
- BSN• NEW ADSHEL OR OTHER SHELTER (NO EXISTING SHELTER ON SITE)
- BSN\* NON ADVERTISING ADSHEL SHELTER
- BSN◡ ADVERTISING ADSHEL SHELTER
- BSN(R) RELOCATED NON ADVERTISING, NON ADSHEL SHELTER
- BSN(D) DOUBLE ADSHEL SHELTER

**NOTES.**

1. TOTAL NUMBERS OF NEW ADVERTISING SHELTERS TO BE BUILT ARE AS FOLLOWS

	ADVERTISING SHELTER	NON-ADVERTISING SHELTER
PHASE 1	35	18
PHASE 2	52	46
PHASE 3	46	44
TOTALS	133	108

2. SHELTER PHASING SUBJECT TO CHANGE

D	MASTER PLAN rev 3	RL	GG	PE	29.08.08	
C	MASTER PLAN rev 2	RL	GG	TC	26.03.08	
B	GENERAL REVISIONS	SOK				
A	PRELIMINARY	RL	GG	GG	22.02.07	
No	Revision	Note: * indicates signatures on original issue of drawing or last revision of drawing	Drawn	Checked	Approved	Date

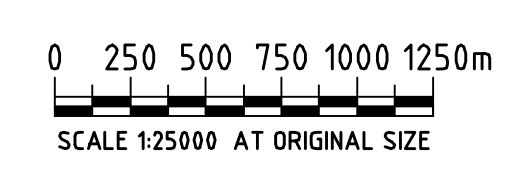

**GHD** CLIENTS | PEOPLE | PERFORMANCE

2nd Floor, Belconnen Chambers  
59 Cameron Ave Belconnen ACT 2617 Australia  
PO Box 36 Belconnen ACT 2617  
T 61 2 6253 1999 F 61 2 6253 1911  
E cbrmail@ghd.com.au W www.ghd.com.au

**DO NOT SCALE**

Drawn RL Design GG  
Drafting Check Design Check  
Approved  
Date  
Scale AS SHOWN

Conditions of Use:  
This document may only be used by GHD's client (and any other person who GHD has agreed can use this document) for the purpose for which it was prepared and must not be used by any other person or for any other purpose.

This Drawing must not be used for Construction unless signed as Approved

Client **ROADS ACT**  
Project **AD AND NON AD BUS SHELTERS IN THE ACT**  
Title **PROPOSED BUS SHELTER LOCATIONS**  
Drawing No: **23-12034-C001**

Original Size **A1** Rev: **D**





**GHD Pty Ltd** ABN 39 008 488 373

59 Cameron Avenue Belconnen ACT 2617



PO Box 36 Belconnen ACT 2616 Australia

T: 61 2 6253 1999 F: 61 2 6253 1911 E: cbrmail@ghd.com.au

© GHD Pty Ltd 2008

This document is and shall remain the property of GHD Pty Ltd. The document may only be used for the purposes for which it was commissioned and in accordance with the Terms of Engagement for the commission. Unauthorised use of this document in any form whatsoever is prohibited.

#### Document Status

Rev No.	Author	Reviewer		Approved for Issue		
		Name	Signature	Name	Signature	Date
0	G Gardner					
1	G Gardner	T Chapman		T Chapman		7/3/07
2	R Latimer	G Gardner		T Chapman		26/3/08
3	R Latimer	G Gardner		<del>G Allard</del> Peter Evans		29/8/08