

Australian Capital Territory

# Fair Trading (Consumer Product Standards) (Prams and Strollers) Standard 2009 (No 1)\*

Notifiable instrument NI2009–229

made under the

**Fair Trading (Consumer Product Standards) Regulation 2009, regulation 18.2 (Safety standard – prams and strollers)**

---

## **1 Name of instrument**

This instrument is the *Fair Trading (Consumer Product Standards) (Prams and Strollers) Standard 2009 (No 1)*.

## **2 Commencement**

This instrument commences on the day that the Fair Trading (Consumer Product Standards) Regulation 2009 commences.

## **3 Prams and strollers standard**

The standard specified in regulation 18.2 of the Fair Trading (Consumer Product Standards) Regulation 2009, at Schedule 1, is notified as the standard to apply to prams and strollers in the ACT.

Simon Corbell  
Attorney General  
30. 4. 2009

\*Name amended under Legislation Act, s 60

## **Schedule 1**

### **COMMONWEALTH OF AUSTRALIA**

Trade Practices Act 1974

Consumer Protection Notice No 8 of 2007

### **CONSUMER PRODUCT SAFETY STANDARD FOR PRAMS AND STROLLERS**

I, Chris Pearce, pursuant to subsection 65E (1) of the Trade Practices Act 1974 and for the purposes of section 65C of that Act, hereby DECLARE that from 1 July 2008 the consumer product safety standard for prams and strollers is the standard approved by Standards Australia specified in Division 1 of the Schedule, as varied by Division 2 of the Schedule.

#### **THE SCHEDULE**

##### **Division 1: The Standard**

Australian/New Zealand Standard AS/NZS 2088:2000, Prams and strollers – Safety requirements, approved by Standards Australia and published on 15 December 2000.

##### **Division 2: Variations**

Standard AS/NZS 2088:2000 is varied by

- (i) In Clause 1 deleting the first sentence and substituting a new sentence as follows:

“This Standard specifies safety requirements for prams and strollers.”;
- (ii) Deleting Clauses 2, 3, 5 and 6 entirely;
- (iii) Deleting Clauses 7.1, 7.2, 7.3, 7.4 and 7.5;
- (iv) In Clause 7.6 deleting the sentence “(See Note to Clause 7.5)”, and adding a second paragraph as follows:

“The colour of the parking device actuator shall be red. The surrounding frame work and mouldings shall be a contrasting colour.”;
- (v) Deleting Clause 7.7 entirely;
- (vi) In Sub-clause 7.8.1.1 paragraph (a) deleting the words “comprising shoulder,” and substituting the words “that includes”, and deleting the sentence “An example is shown in Figure 3.”;
- (vii) In Sub-clause 7.8.1.1 deleting paragraphs (b), (c) and (d) and in paragraph (e) deleting the words “Items (a) and (b)”, and substituting the words “Item (a)”;
- (viii) Deleting Figure 3;
- (ix) Deleting Sub-clause 7.8.1.2;
- (x) In Sub-clause 7.8.1.3 deleting the words “at a point where the seat cannot be pulled away from the frame of the stroller by pulling the restraint straps”;
- (xi) Deleting Clause 7.9;
- (xii) Inserting a new Clause 7.10 as follows:

“7.10 Tether strap

(a) Vehicles shall be provided with a suitable strap to allow the vehicle to be tethered to the vehicle operator while it is in use; and

(b) The tether strap shall be designed to reduce the possibility of it being a strangulation hazard for infants inside or outside the vehicle:

- The length of the strap shall be as short as practical; and

- Any loop in the strap shall have a perimeter of less than 360 mm.”;

(xiii) Deleting Clauses 8.1, 8.2, 8.3 and 8.4 entirely;

(xiv) Deleting Clause 8.6.1;

(xv) In Clause 8.6.2(a), at the beginning of the paragraph inserting the numbering “(i)” before the words “When tested”, and at the end of the paragraph after the word “collapse” deleting the full stop and the words “(See also Note to Clause 7.9.)”, and inserting the following:

“; or

(ii) When tested in accordance with the following procedures the test ball shall not fall out of the seat unit.

Recline the backrest of the seat unit to the most reclined position. Attach, according to the manufacturer’s instructions, the textile parts intended to retain the child (including the rear part of the hood and aprons).

Fix the vehicle to a plane inclined to 45° with respect to the horizontal and 15° with respect to the perpendicular direction of the longitudinal axis considered when inclining the plane to 45°. The vehicle shall be placed along the longitudinal axis of the plane.

Place a test ball comprising a sphere with a hard smooth surface of diameter 120 mm (± 2 mm) and 5 kg (± 0.1 kg) weight on the centre of the junction of the seat and backrest of the vehicle and let the ball roll freely. Record whether the test ball falls out of the seat unit.

Repeat the procedure but with the inclination of the plane of 15° to the opposite side of the longitudinal axis.

Repeat the procedure without inclining the plane at 15° but simply reclined at 45°.”;

(xvi) In Sub clause 8.6.2(b)(i), at the end of the paragraph deleting the full stop and inserting the words “; and”;

(xvii) In sub-clause 8.6.2(b)(ii), at the end of the paragraph deleting the full stop and inserting the following:

“; or

(iii) When tested in accordance with the following procedures, if the small torso probe passes through the gap between the handle and the pram/stroller body, the large head probe shall also pass through.

The probes used in this test are made of hard smooth material fitted with suitable handgrips, comprising:

- a small torso probe with dimensions as shown in Figure A below;

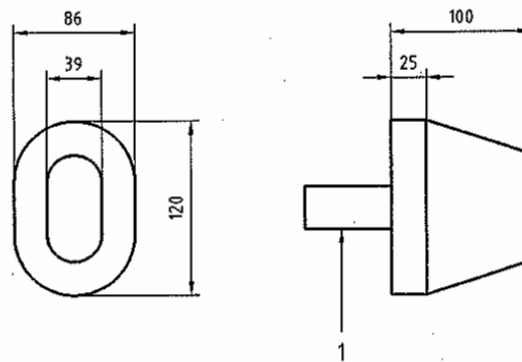

Figure A

Notes to figure A: - Dimensions are in mm;  
- 1 is the handgrip

and

- a large head probe in the shape of a cylinder of diameter 223 mm and length 100 mm, with a handgrip fitted to an end of the cylinder. These probes have dimensional tolerances of  $\pm 2$  mm.

Check whether the small torso probe can pass through the gap between the handle and the end of the pram/stroller body applying a force of 90 N.

Check if the large head probe passes through the opening when pushed along the axis of the handgrip, with a force not exceeding 5 N.”;

- (xviii) Deleting Clauses 8.8, 8.9, 8.10, 9 and 10 entirely;
- (xix) In Clause 11.1 after paragraph (e) inserting a new paragraph (f) as follows:
  - “(f) A notice placed on the tether strap, as follows:  
WARNING: USE THIS STRAP TO STOP THE PRAM/STROLLER\*  
ROLLING AWAY”;
- (xx) In Clause 11.2 deleting the words and substituting the following:
  - “11.2 Legibility of marking  
The wording shall be clearly legible and the marking specified in clauses 11.1(c), (d), (e), and (f) shall be in characters not less than 2.5 mm high.”;
  - and
- (xxi) Deleting Appendices B, C, D, E, F, G, H, K, O, P and Q.

Dated this 27<sup>th</sup> day of June 2007

Chris Pearce  
Parliamentary Secretary to the Treasurer