

Australian Capital Territory

Work Health and Safety (Preventing Falls in Housing Construction) Code of Practice 2011*

Notifiable instrument NI 2011 – 758

made under the

Work Health and Safety Act 2011, section 274 (Approved Codes of Practice)

1 Name of instrument

This instrument is the Work Health and Safety (Preventing Falls in Housing Construction) Code of Practice 2011.

2 Commencement

This instrument commences on 1 January 2012.

3 Code of Practice Approval

Under section 274 of the *Work Health and Safety Act 2011* (the Act), and being satisfied that this code of practice was developed by a process described in s274 (2) of the Act, I approve the ACT Work Health and Safety (Preventing Falls in Housing Construction) Code of Practice 2011.

Dr Chris Bourke
Minister for Industrial Relations
15 December 2011

*Name amended under Legislation Act, s 60

PREVENTING FALLS IN HOUSING CONSTRUCTION

Code of Practice

Table of Contents

FOREWORD	4
SCOPE AND APPLICATION	4
1. INTRODUCTION	6
1.1 Who has health and safety duties in relation to falls?	6
1.2 The meaning of key terms.....	7
1.3 Consulting workers.....	7
1.4 Consulting, cooperating and coordinating activities with other duty holders	7
2. FALL PROTECTION MEASURES	9
2.1 Hierarchy of control	9
2.2 Reasonably practicable	10
2.3 Training, information, instruction and supervision	10
3. WORK ON THE GROUND OR ON A SOLID CONSTRUCTION	12
3.1 Work on the ground.....	12
3.2 Work on a solid construction	12
4. FALL PREVENTION DEVICES	14
4.1 Temporary work platforms.....	14
5. WORK POSITIONING SYSTEMS	21
6. FALL-ARREST SYSTEMS	22
6.1 Catch platforms	22
6.2 Individual Fall-Arrest Systems.....	22
6.3 Safety nets	22
7. USE OF PORTABLE LADDERS AND ADMINISTRATIVE CONTROLS	24
7.1 Risk Assessment.....	24
7.2 Portable ladders	24
7.3 Administrative control measures	30
8. SAFE WORK METHODS FOR COMMON TASKS	31
8.1 Floor laying.....	31
8.2 Fixing ceiling joists and upper level floor joists.....	32
8.3 Guarding openings	33
8.4 Wall framing	34
8.5 Installing prefabricated roof trusses	34
8.6 Constructing conventional or stick roof	41
8.7 Fixing roof battens to trusses	41
8.8 Installation of battens	42
9. ROOFING TASKS	43
9.1 Risk controls - General.....	43
9.2 Critical angle.....	43
9.3 Access and egress	43
9.4 Guardrail systems for roofing work.....	43
9.5 Catch platforms	45
9.6 Steep roofs	45
9.7 Installation of sarking – tile roofing	46
9.8 Installation of perimeter battens – metal roofing	46
9.9 Fixing fascias and gutters.....	46
APPENDIX A: REFERENCED DOCUMENTS AND FURTHER READING	47
APPENDIX B: TIMBER SCAFFOLDS	48

FOREWORD

This Code of Practice on how to prevent the risks of falls in housing construction is an approved code of practice under section 274 of the *Work Health and Safety Act*.

An approved code of practice is a practical guide to achieving the standards of health, safety and welfare required under the *Work Health and Safety Act* (the WHS Act) and the Work Health and Safety Regulations (the Regulations).

A code of practice applies to anyone who has a duty of care in the circumstances described in the code. In most cases, following an approved code of practice would achieve compliance with the health and safety duties in the WHS Act, in relation to the subject matter of the code. Like regulations, codes of practice deal with particular issues and do not cover all hazards or risks that may arise. The health and safety duties require duty holders to consider all risks associated with work, not only those for which regulations and codes of practice exist.

Codes of practice are admissible in court proceedings under the WHS Act and Regulations. Courts may regard a code of practice as evidence of what is known about a hazard, risk or control measure and may rely on the code in determining what is reasonably practicable in the circumstances to which the code relates.

Compliance with the WHS Act and Regulations may be achieved by following another method, such as a technical or an industry standard, if it provides an equivalent or higher standard of work health and safety than the code.

An inspector may refer to an approved code of practice when issuing an improvement or prohibition notice.

This Code of Practice has been developed by Safe Work Australia as a model code of practice under the Council of Australian Governments' *Inter-Governmental Agreement for Regulatory and Operational Reform in Occupational Health and Safety* for adoption by the Commonwealth, state and territory governments.

A draft of this Code of Practice was released for public consultation on 26 September 2011 and was endorsed by the Select Council on Workplace Relations on [to be completed].

SCOPE AND APPLICATION

The Code provides practical guidance for persons conducting a business or undertaking on how to eliminate, or if that is not possible, minimise the risk of falls from height in housing construction.

This Code applies to the construction or extension of:

- detached houses
- attached dwellings, separated from each other by a fire resisting wall, such as terrace, row or town houses
- boarding and guest houses, hostels or similar with a floor area <300m², and
- ancillary buildings to the above, such as private garages, gazeboes and carports.

The Code does not apply to the maintenance or renovation of buildings.

Note: The above points are based on Classes 1, 2 and 10 of the Building Code of Australia.

This Code does not apply to multi-storey buildings above two habitable storeys¹.

¹ This clarifies the intended scope of the *National Standard for the Prevention of Falls in Housing Construction* (2010).

This Code should be read in conjunction with the *Code of Practice: How to Prevent Falls at Workplaces* and the *Code of Practice: Construction Work*.

How to use this Code

In providing guidance, the word 'should' is used in this Code to indicate a recommended course of action, while 'may' is used to indicate an optional course of action.

This Code also includes various references to sections of the WHS Act and Regulations which set out the legal requirements. These references are not exhaustive. The words 'must', 'requires' or 'mandatory' indicate that a legal requirement exists and must be complied with.

1. INTRODUCTION

Falls are a major cause of death and serious injury in Australian workplaces. Fall hazards are found when carrying out common tasks in the construction of a typical one or two storey house (see Figure 1). Falls can also occur at ground level into holes, for example trenches or service pits.

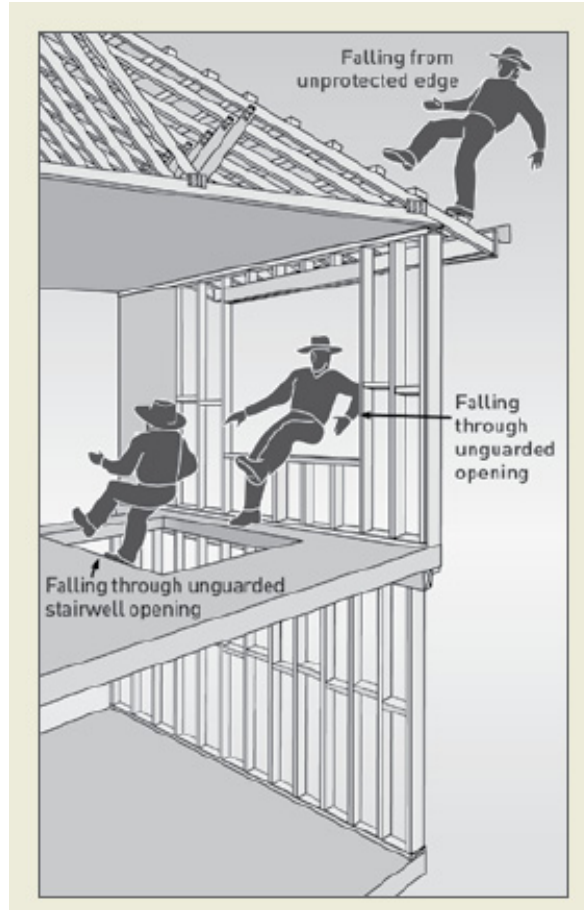

Figure 1: Potential falls in the housing construction industry

1.1 Who has health and safety duties in relation to falls?

A person conducting a business or undertaking has the primary duty under the WHS Act to ensure, so far as is reasonably practicable, that workers and other persons are not exposed to health and safety risks arising from the business or undertaking.

A person conducting a business or undertaking has more specific obligations under the WHS Regulations to manage the risk of a fall by a person from one level to another, including requirements to:

- ensure, so far as is reasonably practicable, that any work involving the risk of a fall is carried out on the ground or on a solid construction
- provide safe means of access to and exit from the workplace, and
- provide adequate protection against the risk of falls.

The WHS Regulations classify a number of activities as 'high risk construction work' for which a safe work method statement (SWMS) must be prepared before the work starts. High risk construction work includes work that involves a risk of a person falling more than 2 metres. Further information on developing a SWMS can be found in the *Code of Practice: Construction Work*.

Designers, manufacturers, suppliers, importers and installers of plant or structures that could be used for work must ensure, so far as is reasonably practicable, that the plant or structure is without risks to health and safety. Designers of plant or structures have an important role in eliminating or minimising the risks of falls in the design stage.

Officers, such as company directors, have a duty to exercise due diligence to ensure that the business or undertaking complies with the WHS Act and Regulations. This includes taking reasonable steps to ensure that the business or undertaking has and uses appropriate resources and processes to eliminate or minimise risks of falls from one level to another that are likely to cause injury.

Workers have a duty to take reasonable care for their own health and safety and that they do not adversely affect the health and safety of other persons. Workers must comply with any reasonable instruction given by the person conducting the business or undertaking.

1.2 The meaning of key terms

Fall means a fall by a person from one level to another.

Risk of a fall means a circumstance that exposes a worker while at work, or other person while at or in the vicinity of a workplace, to a risk of a fall that is reasonably likely to cause injury to the worker or other person. This includes circumstances in which the worker or other person is:

- in or on plant or a structure that is at an elevated level
- in or on plant that is being used to gain access to an elevated level
- in the vicinity of an opening through which a person could fall²
- in the vicinity of an edge over which a person could fall
- on or in the vicinity of a surface through which a person could fall, or
- on or near the vicinity of a slippery, sloping or unstable surface.

Risk control means taking action to eliminate health and safety risks so far as is reasonably practicable, and if that is not possible, minimising the risks so far as is reasonably practicable. Eliminating a hazard will also eliminate any risks associated with that hazard.

Competent person means a person who has acquired through training, qualification or experience the knowledge and skills to carry out the task.

1.3 Consulting workers

Consultation involves sharing of information, giving workers a reasonable opportunity to express views and taking those views into account before making decisions on health and safety matters.

The WHS Act requires that you consult, so far as is reasonably practicable, with workers who carry out work for you who are (or are likely to be) directly affected by a work health and safety matter.

If the workers are represented by a health and safety representative, the consultation must involve that representative.

1.4 Consulting, cooperating and coordinating activities with other duty holders

The WHS Act also requires that you consult, cooperate and coordinate activities with all other persons who have a work health or safety duty in relation to the same matter, so far as is reasonably practicable.

² For example within 1.2m of an edge or opening if the person is working at the same level as the edge or opening (i.e. not on an elevated platform or a ladder).

There are often multiple contractors involved in building a house, who may each have responsibility for the same health and safety matters because they are involved in the same activities or share the same workplace. In these situations, each duty holder should exchange information to find out who is doing what and work together in a co-operative and co-ordinated way so that all risks are eliminated or minimised as far as reasonably practicable.

For example an electrician working on a roof should consult with other duty holders, including the builder, who are also working on the site to co-ordinate the provision of suitable fall prevention and co-operate with each other to ensure that each of their activities do not create risks for other workers on the site.

Further guidance is available in the *Code of Practice: Work Health and Safety Consultation, Co-operation and Co-ordination*.

2. FALL PROTECTION MEASURES

Regulation 34-38: In order to manage risk under the WHS Regulations, a duty holder must:

- a) identify reasonably foreseeable hazards that could give rise to the risk
- b) eliminate the risk so far as is reasonably practicable
- c) if it is not reasonably practicable to eliminate the risk – minimise the risk so far as is reasonably practicable by implementing control measures in accordance with the hierarchy of risk control
- d) maintain the implemented control measure so that it remains effective, and
- e) review, and if necessary revise all risk control measures so as to maintain, so far as is reasonably practicable, a work environment that is without risks to health and safety.

Managing risk is a systematic process that involves:

- identifying hazards that may cause injury
- if necessary, assessing the risks associated with these hazards
- implementing risk control measures, and
- reviewing risk control measures to ensure they are effective.

This Code provides guidance on the type of control measures to prevent persons falling from one level to another on housing construction sites. The guidance is set out in the order of the hierarchy of control.

2.1 Hierarchy of control

To provide adequate protection against the risks of falls, specific control measures must be implemented where it is reasonably practicable to do so:

Level 1 controls: Carry out any work that involves the risk of a fall on the ground or on a solid construction. A building or structure that is used as an existing place of work and includes safe access and egress from which there is no risk of a fall from one level to another, for example properly constructed stairs with fixed handrails, flat roofs with a parapet or permanently installed guardrails around the edges.

Level 2 controls: Carry out the work using a fall prevention device (for example, temporary work platforms, installing guard rails) if it is reasonably practicable to do so

Level 3 controls: Carry out the work using a work positioning system (for example, a travel restraint system) if it is not reasonably practicable to provide a fall prevention device

Level 4 controls: Carry out the work using a fall arrest system so far as is reasonably practicable, if it is not reasonably practicable to provide a fall prevention device or a work positioning system.

Level 5 controls: If after considering all of the control measures listed above a risk remains, and there is no reasonably practicable alternative, you must implement administrative controls. The work may also be undertaken from ladders.

A risk assessment will help determine what control measures are needed. The height at which the work is carried out is not the only risk factor that should be considered when deciding which control measures to use. However, the greater the height, the greater the risk and therefore more consideration must be given to implementing control measures at the top of the hierarchy.

Level 1, 2, 3 or 4 control measures are usually necessary when working at a height of 2 metres or more. Depending on the risk assessment, ladders and administrative control measures may be all that is reasonably practicable to implement for work at heights of less than 2 metres (see Chapter 7).

In some cases, a combination of control measures may be necessary, for example, using safety harnesses while working from an elevating work platform.

Fall protection measures must also be:

- fit for purpose
- suitable for the nature and duration of the work
- set up and used correctly

You should also ensure that the control measures you select do not create new hazards, for example, electrical risks from contact with overhead power lines or crushing and entanglement from plant, for example elevating work platforms.

2.2 Reasonably practicable

'Reasonably practicable' is defined in the WHS Act and takes into account a number of factors that can help you decide what can reasonably be done to control the risk of a fall in the circumstances.

'Reasonably practicable' does not just mean the cost in dollar terms. Determining what is reasonably practicable includes taking into account and weighing up the following:

Severity of the hazard or risk

How likely is it that a worker will fall? How serious are the injuries likely to be? If each time a worker is exposed to an uncontrolled risk which may result in severe injury or death, then this is an important factor.

State of knowledge

What is known about the hazard and the ways of controlling the risk? How do similar businesses or workplaces control the risk of falling? What information can WHS professionals, industry associations, unions and government bodies provide? What can you find out from manufacturers and suppliers about risk control equipment?

Availability and suitability of ways to eliminate or minimise the risk

Are the fall protection measures you have identified available? Are they designed and constructed for the site, the task and all people using them? Manufacturers/suppliers instructions should be noted prior to commencing tasks.

The cost of removing or mitigating the hazard or risk

What are the costs of eliminating or minimising the risk, taking into account any saving from fewer injuries and potentially improved productivity? Are the costs of implementing the control measures grossly disproportionate to the risk?

2.3 Training, information, instruction and supervision

Section 19: A person conducting a business or undertaking must provide any information, instruction training or supervision necessary to protect all persons from risks to their health and safety arising from work carried out.

Regulation 317: A person conducting a business or undertaking must not direct or allow a worker to carry out construction work unless the worker has successfully completed general construction induction training.

Where workers are exposed to potential falls from working at any height, information, instruction and training must explain:

- the hazards and risks associated with work performed at these heights

- how to follow health and safety procedures associated with this work, including the contents of any SWMS
- the reasons fall protection measures have been set in place and how to use them properly.

Those supervising the work must also receive training. The amount and type of information, instruction and training required will depend on the nature of the work and the risk involved, as well as the type of fall protection measures used.

3. WORK ON THE GROUND OR ON A SOLID CONSTRUCTION

3.1 Work on the ground

Eliminating the need to work at height is the most effective way of protecting workers from the risk of falls. Examples of eliminating the risk by working on the ground include:

- prefabricating roofs at ground level
- prefabricating wall frames horizontally, then standing them up

3.2 Work on a solid construction

Working on a solid construction provides an environment where the likelihood of a fall may be eliminated. 'Solid construction' means an area that:

- is structurally capable of supporting workers, material and any other loads applied to it
- is provided with barriers around its perimeter and around any openings from or through which a person could fall
- has an even, accessible surface and gradient
- has a safe means of entry and exit.

Solid construction should satisfy the following requirements:

Structural strength

Different types of work involve different loads on the supporting surface. Make sure that the surface and its supports can safely carry the expected loads, including workers, materials, tools and equipment. When in doubt, have a structural engineer determine the safe load capacity before use.

Ensure that where props are used to support suspended floors, formwork or similar areas that:

- proprietary brand props are marked with their safe working load
- the props are designed for the loads imposed, and
- the props are tied to each other in the longitudinal and transverse directions to form a stable, freestanding structure.

Surface and gradient

Surfaces of a solid construction should be non-slip and free from trip hazards and traps.

Surfaces of a solid construction should generally not exceed 7 degrees (1 in 8 gradient). Cleated surfaces which provide greater slip resistance, should not be steeper than 20 degrees (1 in 3 gradient).

Edge protection

Perimeter protection must be provided on the exposed edges of a solid construction. These include:

- the perimeters of buildings or other structures
- the perimeters of skylights or other fragile roof materials, and
- openings in floor or roof structures.

Edge Protection Checklist

- The guard rail system should be of robust design and able to withstand the force of someone falling against it.
- Top rails should be between 900 mm and 1100 mm above the working surface.
- Mid-rails should be provided. However, wire mesh infill panels incorporating a toeboard may be used instead of the midrail.
- Toeboards should be provided where reasonably practicable.
- A bottom rail above the toeboard on some roof slopes may be provided for more severe roof slopes. Both a midrail and infill mesh panel will assist in preventing persons and objects from sliding off the roof.
- If access points are required for equipment (e.g. tile elevators) they must be protected adequately to prevent a person falling.
- Every open edge of a stair, landing, platform or shaft opening must be protected to prevent people falling.

Note: Refer to AS 1657 and AS 1567 for further guidance for edge protection.

Void protection

Where workers are working from trestles, ladders and mobile scaffolds on solid construction and they are located in close proximity to floor openings such as stairwells and partially completed floors, edge protection will not prevent a fall into the opening. The openings must be covered and the covers must be capable of withstanding any impact and static loads, and must be fixed to prevent any dislodgement or accidental removal.

Entry and exit

Every solid construction must have safe and suitable means of entry and exit, such as:

- existing floor levels
- permanently installed platforms, ramps, stairways and fixed ladders complying with the AS 1657: *Fixed platforms, walkways, stairways and ladders – Design, construction and installation*
- temporary access ways and temporary stair systems
- secured single portable ladders set up at a slope of 4:1 and extending at least 1 metre above the stepping off point.

Stepladders and trestle ladders should not be used for access to, or egress from, solid construction.

4. FALL PREVENTION DEVICES

A 'fall prevention device' is any fall protection system that once erected or installed requires no further ongoing adjustment, alteration or operation by a worker to ensure the integrity of the system to perform its function as a fall prevention system. Examples include temporary work platforms and guardrails.

4.1 Temporary work platforms

A 'temporary work platform' is a working platform, other than a permanently installed fixed platform, used to provide a working area for the duration of the job. The design of the platform prevents workers from falling. Temporary work platforms commonly used in housing construction include scaffolds (fixed or mobile), elevating work platforms and step platforms.

Scaffolds

Scaffolds are a common means of providing a safe platform for working at height. There is a wide variety of scaffold systems available.

Scaffold working platforms are generally rated as light, medium or heavy duty:

- Light Duty – up to 225 kg per bay. Examples include painting, electrical work, many carpentry tasks and other light tasks. Platforms should be at least two planks wide (approximately 450 mm)
- Medium Duty – up to 450 kg per bay. This is suitable for general trades work. Platforms should be at least four planks wide (approximately 900 mm)
- Heavy Duty – up to 675 kg per bay. This is what is needed for bricklaying, concreting, demolition work and most other work tasks involving heavy loads or heavy impact forces. Platforms should be at least 5 planks wide (approximately 1000 mm)
- Special Duty – has a designated allowable load as designed.

These safe load limits include the weight of people (which is taken to be a nominal 80 kg) plus the weight of any materials, tools and debris on the working platform. Therefore, a properly constructed mobile scaffold with a light duty platform can safely support one worker and 145 kg of tools and material, or two workers and 65 kg of tools and materials.

Information, instruction and training for workers using scaffolds

Where work is performed from a scaffold, ensure that the relevant workers know:

- what loads it can safely take [Safe Working Load (SWL)]
- that unauthorised alterations must not be made to the scaffold (such as removing guardrails, planks, ties, toeboards and braces)
- that working platforms need to be kept clear of debris and obstructions along their length
- that incomplete or defective scaffolds must never be accessed.

Where mobile scaffolds are in use, the scaffold should:

- remain level and plumb at all times
- be kept well clear of powerlines, open floor edges and penetrations
- never be accessed until all castors are locked to prevent movement
- never be moved while anyone is on the scaffold.

Trestle scaffolds

Trestle scaffolds are generally not suitable for working at 2 metres or above. If they are used at heights greater than 2 metres, guardrailing should be used so as to prevent persons from falling off the open side or end of the work platform (see Figure 2). The system (including planks) must be assembled according to the manufacturer's specifications.

Some trestle ladder scaffolds include outriggers. Trestle ladder scaffolds are only suited to light duty tasks, such as painting and rendering.

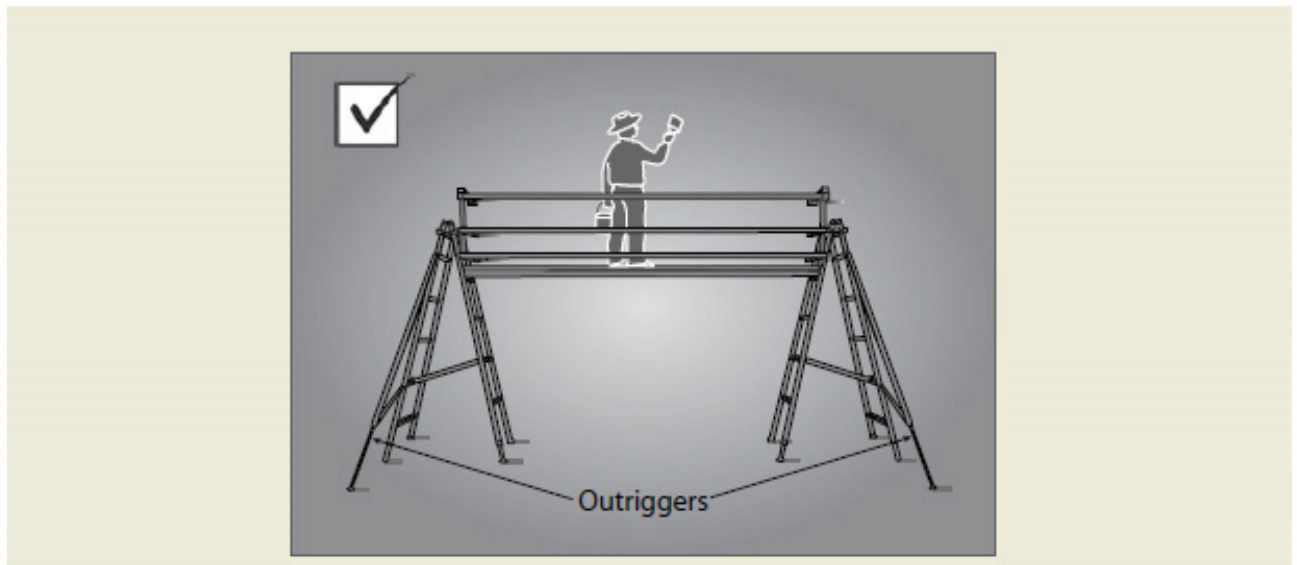

Figure 2: Trestle ladder scaffold with guardrailing and outriggers for stability

When adjusting the height of a brick layer's trestle scaffold, make sure that only the purpose designed pins are used. Do not use nails or pieces of reinforcing bar.

Work must only be performed between the trestles. Where a trestle scaffold is more than one bay in length, heavy loads must be placed directly over the trestles.

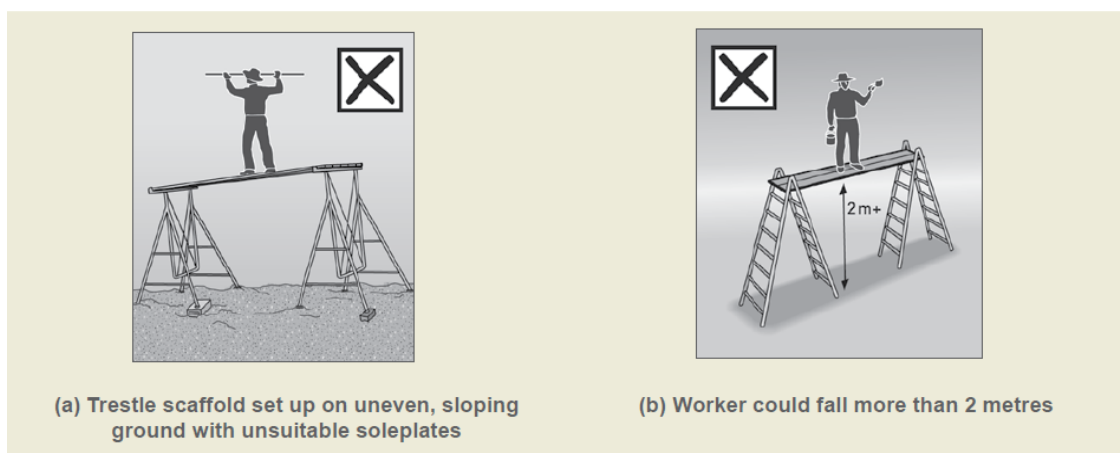

Figure 3: Examples of wrongly used trestle scaffolds

Scaffolding checklist

Control measures include:

- scaffolding must conform to AS/NZS 4576 and the AS/NZS 1576 series
- if scaffolding is to be erected from which a person or object could fall more than 4 metres, the scaffold must be erected, altered and dismantled by a licensed scaffolder
- an unlicensed person must not alter scaffolding without authority from a competent person
- prefabricated scaffolds must be of the same type and not mixed components, unless the mixing of components has been approved by the manufacturer. AS/NZS 4576 sets out the assurances that are needed before the components of different prefabricated scaffolding systems can be mixed in a scaffold. Unauthorised mixing of components from different manufacturers has resulted in scaffold incompatibilities and failures, posing significant risks to persons using the scaffolding
- mobile tower frame scaffolds can be used to provide safe working platforms
- scaffolding that is incomplete and left unattended should have danger tags and warning signs attached at appropriate locations to prevent use
- scaffolding exceeding a deck height of 4 metres must be inspected and tagged by a competent person before use, after any alteration or repair, and at intervals not greater than 30 days
- only a licensed person or a trainee under direct supervision of a licensed person may modify the height of a scaffold exceeding a deck height of 4m
- additional inspections must be carried out by a competent person following an occurrence that may affect the stability such as impact from mobile plant or a severe storm
- safe access to and egress from the scaffold must be provided, and
- edge protection must be provided at every open edge of a work platform.

Elevating work platforms

Elevating work platforms (EWPs) include scissor lifts, cherry pickers, boom lifts and travel towers. There are battery powered and internal combustion engine types. Some are designed for hard flat surfaces only, while others are designed to be operated on rough terrain.

Persons working in travel towers, boom lifts or cherry pickers must wear a properly anchored safety harness. Persons working in scissor lifts are not required to wear a safety harness.

Workers using EWPs must be trained and instructed in the safe loading and safe operating procedures for the particular brand and type of plant. Workers must also be licensed when operating boom lifts with a boom length of 11 metres or more.

Elevating Work Platform checklist

Control measures include:

- workers operating the platform must be trained and instructed in safe operating procedures for the particular brand and type of equipment
- the platforms should only be used as working platforms. They should not be used as a means of access to and egress from a work area unless the conditions set out in AS 2550.10 are met
- unless designed for rough terrain, the platforms must be used only on a solid level surface
- the surface area must be checked to make sure that there are no penetrations or obstructions which could cause uncontrolled movement or overturning of the platform
- when designed as rough terrain platforms, the manufacturer's/suppliers' instructions should be consulted for information on safe operation
- the training provided must include safe use of the fall-arrest equipment and emergency rescue procedures
- people working in cherry pickers must wear an anchored safety harness and lanyard incorporating a shock absorber as precaution against mechanical failure of the basket. The lanyard should be as short as possible.

Step platforms

Commercially available step platforms are stable and provide a much larger work surface than a stepladder. Some models are collapsible and adjustable to heights above 2 metres.

Perimeter guardrailing

Guardrailing may be used to provide effective fall protection at:

- the perimeters of buildings or other structures
- the perimeters of skylights or other fragile roof materials
- openings in floor or roof structures
- edges of excavations.

Guardrailing must:

- incorporate a top rail 900 mm-1100 mm above the working surface
- incorporate a midrail
- incorporate a toeboard (except where it may be impractical to do so) and alternative control
- measures, such as 'no go' zones, to ensure no persons are at risk of being hit by falling objects from the work above
- be of robust construction and designed in accordance with the relevant Australian Standards.

Wall framing incorporating studs at 600 mm centres and one row of noggings is an acceptable alternative to guardrailing. Where the frame incorporates window or door openings additional members

must be fitted across these openings which provides the equivalent fall protection to the guardrailing described above.

Proprietary systems must be configured, installed, used and dismantled according to the manufacturer's/suppliers' instructions.

Where timber guardrailing is not specifically designed in accordance with AS 1657, the member sizes set out below may be used for guardrail and post sizes respectively.

TIMBER GUARDRAILS		
Guardrail size depth	Maximum guardrail span (m)	
X width (nominal sizes) (mm)	F8 HW or MGP 12 seasoned pine	F7 pine
100 x 38	2.7	N/A
100 x 50	3.5	N/A
2 nos (90 x 35)**	N/A	3.5
** Timber members to be nailed together at maximum 300mm intervals in 'T' or 'L' sections		

Wherever feasible, guardrailing should be constructed so that when an outward force is applied the posts are subjected to bending about their strong axis (see Figure 4).

The manufacturer/supplier of proprietary guardrailing systems must provide the detail and instructions.

Building timber must be inspected by a person with relevant qualifications or experience to determine whether it is suitable for use as guardrailing. The methods for connecting timber posts to the support structure or rails to posts must have adequate strength for the purpose intended (Figure 4 gives two connection detail examples).

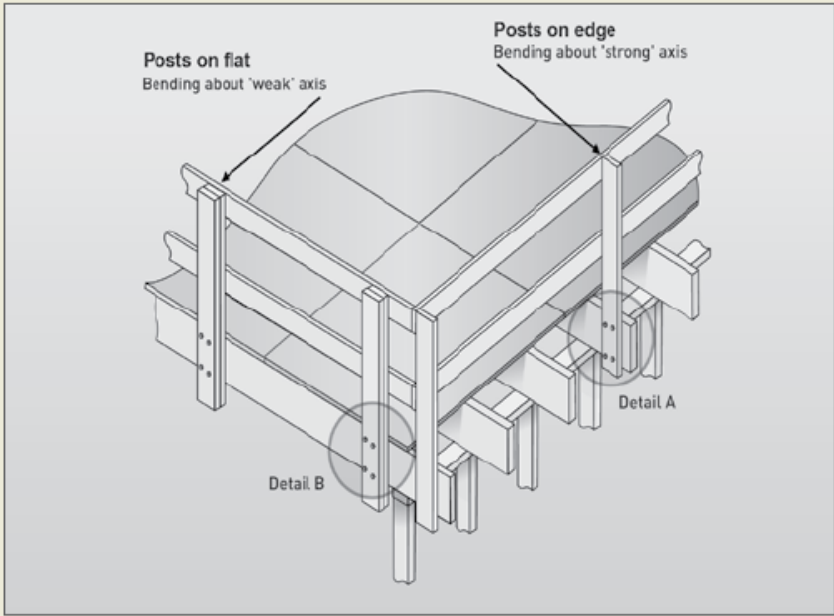

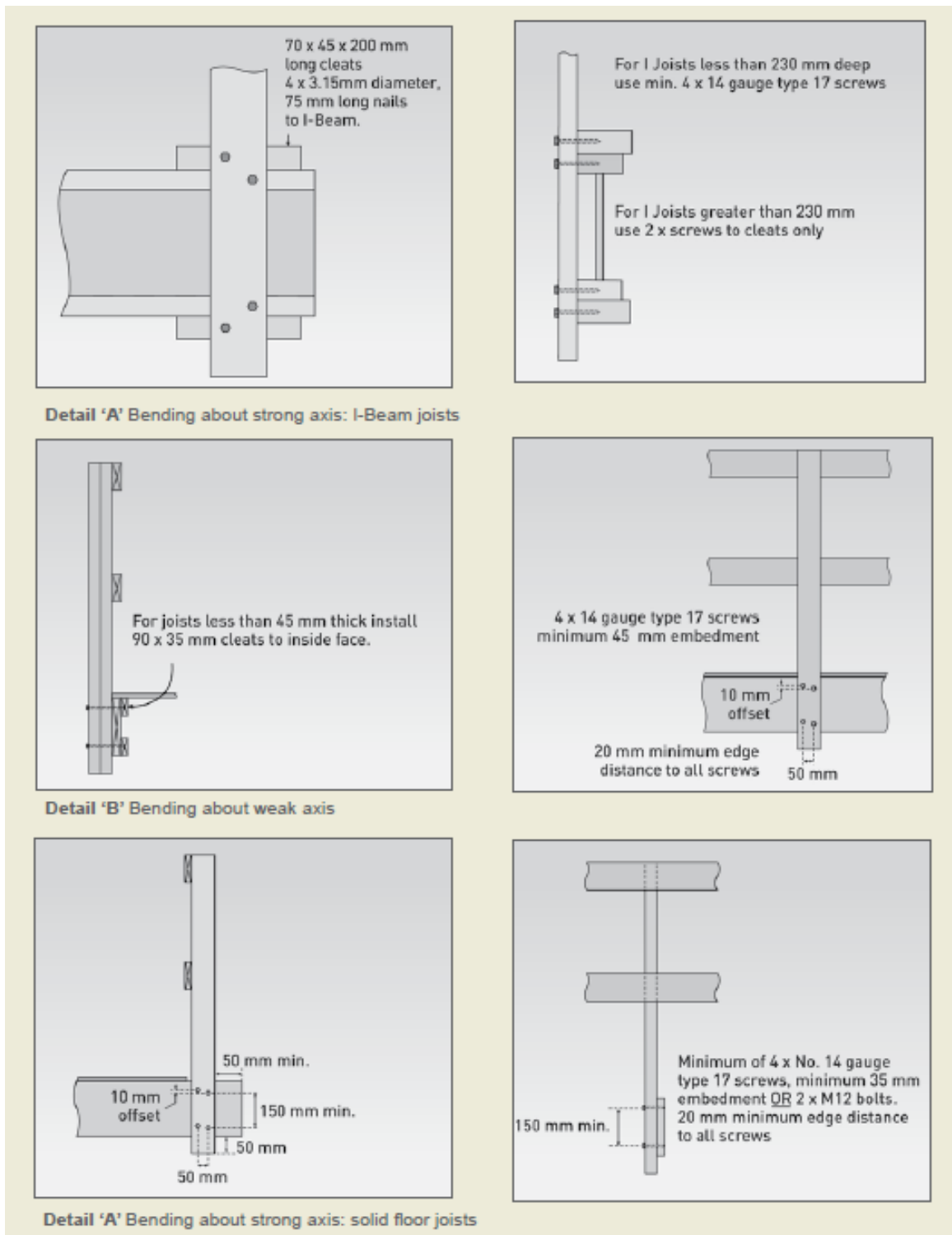

Figure 4: Timber guardrails

Guardrails for trenching works

Where trenching works present a risk of a person falling 2 or more metres on site, any such risk may be controlled by:

- the provision of guardrailing, or where possible
- the provision of a barrier, approximately 1.5 metres back from the excavation, to prevent persons approaching the trench.

Further information on excavation work, see the Code of Practice: *Excavation Work*.

5. WORK POSITIONING SYSTEMS

A 'work positioning system' is equipment, other than temporary work platforms, that enables a worker to be positioned and safely supported at a work location to carry out a task.

Travel restraint systems

A travel restraint system prevents the user from approaching an unprotected edge on a building or structure. Generally, the system consists of a safety harness connected by a lanyard to a suitable anchorage point or static line. This equipment must be set up to prevent the worker from reaching an edge from where a fall may occur.

A purpose-designed roof anchor, when used in accordance with the manufacturer's/suppliers' instructions, may be used as part of a travel restraint system on metal deck or tiled roofs and should only be used for tasks of short duration.

Travel restraint systems must only be used if it is not reasonably practicable to adopt a fall protection system that prevents falls by providing a physical barrier (such as guardrailing). This is because travel restraint systems require a high level of user skill to operate safely and require greater supervision. If using travel restraint systems, training and supervision is mandatory.

Travel restraint systems are not fall-arrest devices. Typical anchorage points for these systems are not designed for the impact loads applied in the event of a fall. Therefore, where there is any possibility that a person using a travel restraint device may approach an edge from where a fall is possible, a travel restraint system must not be used. Consequently, inertia reels and retractable lanyards are not to be used as they do not restrict travel and can allow the worker to fall.

6. FALL-ARREST SYSTEMS

A fall-arrest system means equipment intended to reduce the severity of an injury to a person if a fall does occur. These systems include catch platforms, individual fall-arrest systems and industrial safety nets.

6.1 Catch platforms

A catch platform is a temporary platform located below a work area to catch a worker in the event of a fall. The platform must be designed to sustain the maximum potential impact load.

Catch platforms should:

- incorporate a fully planked deck
- be positioned so as to maintain a minimum of 2 metres beyond all unprotected edges of the work area, except where extended guardrailing is fitted to the catch platform
- be positioned as close as possible to the underside of the work area, and in no case be greater than 1 metre below the work area.

Heavy duty trestle scaffolds can be used as simple and inexpensive catch platforms, particularly in voids and stairwells.

6.2 Individual Fall-Arrest Systems

Individual fall-arrest systems (IFAS) are intended to arrest a falling person safely and reduce the impact of the fall. If using IFAS, training and supervision is mandatory. The safe and correct use of IFAS relies on many factors, including the design and availability of substantial engineered anchorage points. IFAS have limited application in housing construction because:

- they require ongoing supervision and are awkward and cumbersome to use on residential roofs
- they are generally appropriate for work at heights over 6.5 metres (workers in residential construction would generally strike the ground before the system properly deploys)
- it is often difficult to achieve the minimum required 15kN anchorage point rating on a timber roof (particularly when only partially completed)
- workers are susceptible to tripping caused by the lanyard
- they require a rescue procedure to stop the fallen worker from succumbing to suspension trauma.

6.3 Safety nets

Safety nets can provide a satisfactory means of protection while allowing workers maximum freedom of movement.

An internal safety net can be effectively used over stairwell openings.

Safety Net Checklist

Where it is reasonably practicable for safety nets to be used as a fall injury prevention system, ensure that:

- safety nets are in position before any work is commenced
- safety nets are constructed of material of sufficient strength to catch a falling person or debris
- safety nets are installed and maintained by a licensed rigger or scaffolder
- elevating work platforms (e.g. a cherry picker or scissor lift) are used for the installation. If this is not possible, scaffolding and fall-arrest systems must be used
- safety nets are hung as close as is practicable to the underside of the working area, but no more than 2 metres below the working area
- perimeter safety nets are installed where there is no edge protection to prevent workers falling over the edges
- the safety net has sufficient tension and clearance to prevent a falling person contacting any surface or structure below the net
- no type of material is allowed to accumulate in suspended safety nets
- no welding or oxy cutting is performed above safety nets
- safety nets are not used in an environment that exposes them to damage from chemicals, sun or heat
- safety nets are inspected, particularly after installation, relocation or repair
- safety nets are stored correctly in dry, shaded areas with good air circulation.

7. USE OF PORTABLE LADDERS AND ADMINISTRATIVE CONTROLS

Ladders are used extensively in the housing construction industry. However, many falls take place when people are working from ladders.

A fall from almost any height can result in serious injury or death. It is possible that a number of factors can combine to create a dangerous situation. This possibility makes a hazard identification and risk assessment process very important for work at any height.

7.1 Risk Assessment

This Code requires that in situations where persons are working at heights of less than 2 metres, the risk management approach of identifying fall hazards, assessing the risk of a fall occurring, and controlling the risks be adopted.

Assessing the risks of these potential falls does not need to be complicated. In most cases:

- look for the hazards
- decide who might be harmed and how
- if a risk exists, consider ways of doing the task more safely, and
- take action to eliminate the risk, or if it is not reasonably practicable to do so, then minimise the risk.

However, persons must use physical fall prevention measures and a SWMS for the work if the risk assessment identifies the need for such measures to be used.

Some common work tasks performed at heights of less than 2 metres are illustrated below, along with solutions that prevent or minimise the risk associated with these tasks.

7.2 Portable ladders

Generally, ladders are only appropriate for short duration light tasks, such as painting a downpipe, repairing a gutter or carrying out minor electrical installations.

Selection of ladders

It is important to ensure that portable ladders are correctly selected for the task to be undertaken. In doing this, consideration should be given to the duration of the task, the physical surroundings of where the task is to be undertaken and the prevailing weather conditions. For example, metal ladders or metal reinforced ladders must not be used for live electrical work.

Ladder use for construction work typically involves repetitive use and handling, requiring ladders to be of robust design and construction. Accordingly, ladders used for construction work should be industrial grade, not domestic grade.

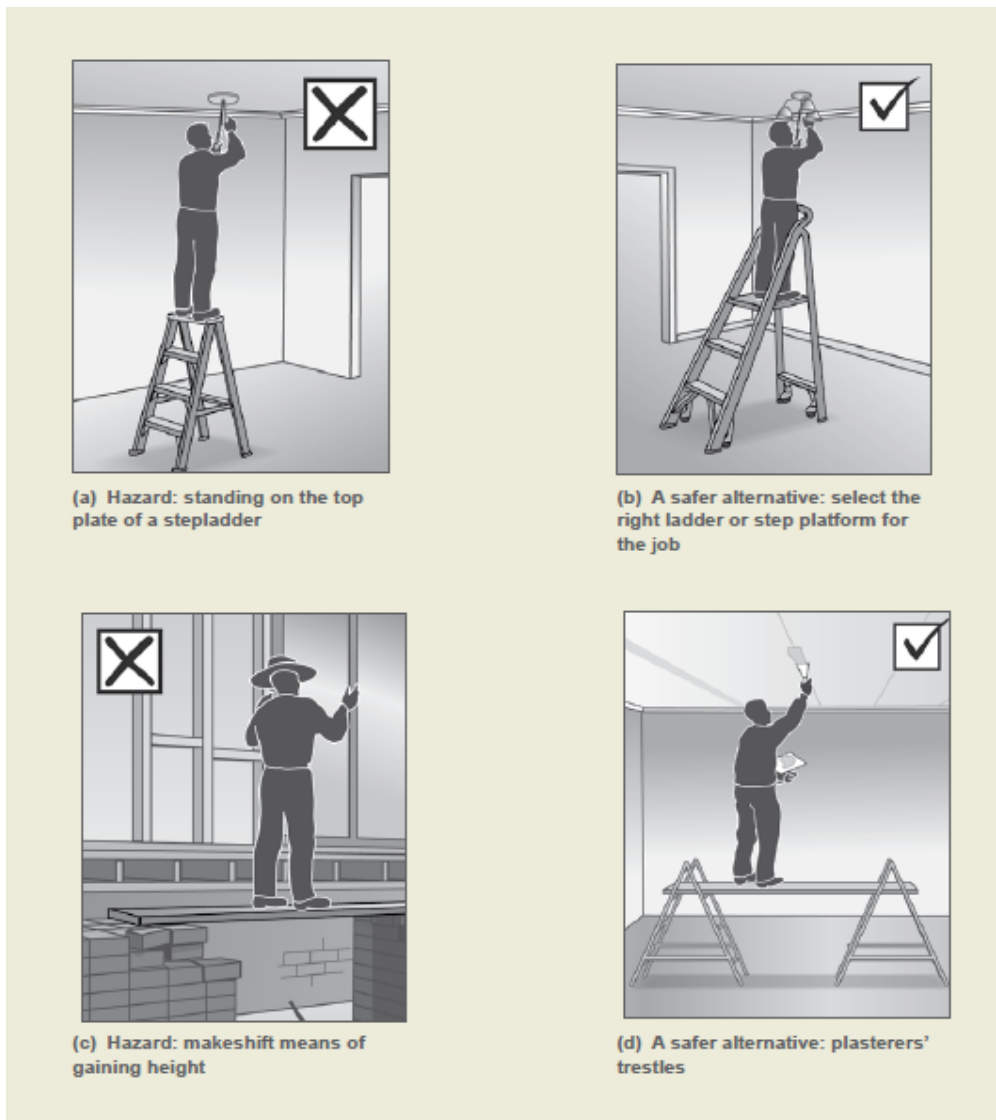

Figure 5: Common work tasks performed at heights of less than 2 meters

Safe use of ladders

Any ladder used at a workplace should be set up on a surface that is solid and stable, and set up so as to prevent the ladder from slipping. Slipping of ladders can be prevented by:

- placing single and extension ladders at a slope of 4:1, and setting up stepladders in the fully opened position, and
- securing single and extension ladders at either the top or bottom, or if necessary, at both ends (see Figure 6).

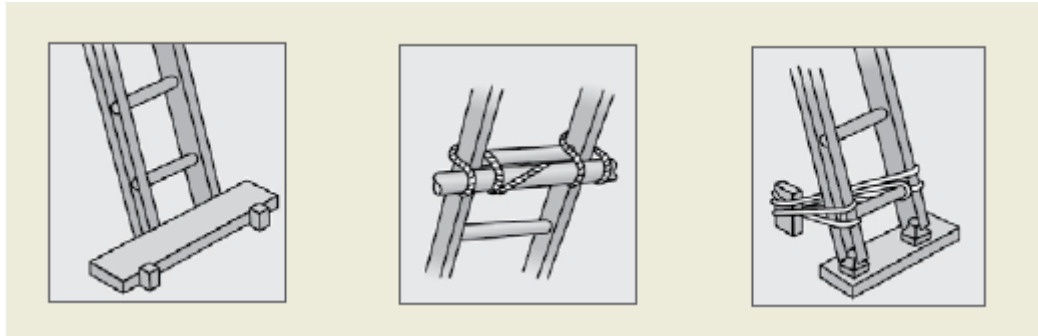

Figure 6: Some effective ways of securing a ladder

Persons using ladders should **not**:

- handle or use ladders where it is possible for the worker or the ladder to make contact with energised power lines, except where the person is qualified to do so
- use metal or metal reinforced ladders when working on live electrical installations
- set up the ladder in places, such as driveways and doorways, where a person or vehicle could hit it. If necessary, erect a barrier or lock the door shut
- use a stepladder near the edge of an open floor, penetration, or on scaffolding to gain extra height
- over-reach (the worker's belt buckle must be within the ladder stiles throughout the work)
- use any power (air, hydraulic, electric or battery) equipment or tool, specifically designed to be operated with two hands, such as concrete cutting saws and circular saws
- use tools which require a high degree of leverage type force which, if released, may cause the user to over balance or fall from the ladder, such as pinch bars
- carry out work such as arc welding or oxy cutting
- work over other people, or
- allow anyone else to be on the ladder at the same time.

Except where additional and appropriate fall protection equipment is used in conjunction with the ladder, any person using a ladder should not:

- face away from the ladder when going up or down, or when working from it
- stand on a rung closer than 900 mm to the top of a single or extension ladder, or
- stand higher than the second tread below the top plate of any stepladder (with the exception of 3-rung step ladders).

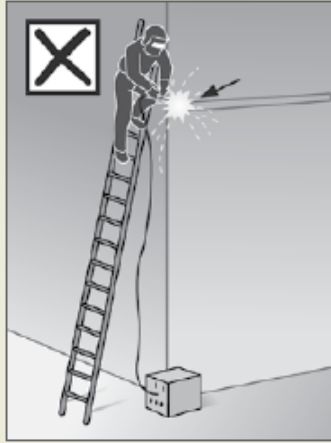

(a) Performing hot work from ladder

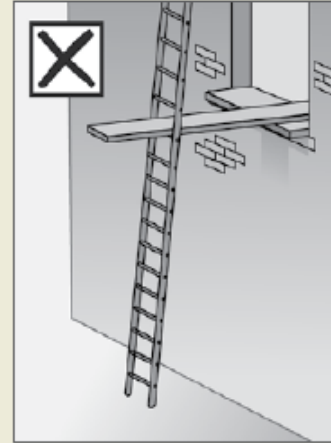

(b) Ladder set up incorrectly

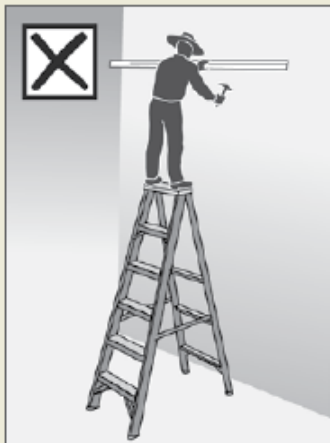

(c) Standing on top plate of stepladder

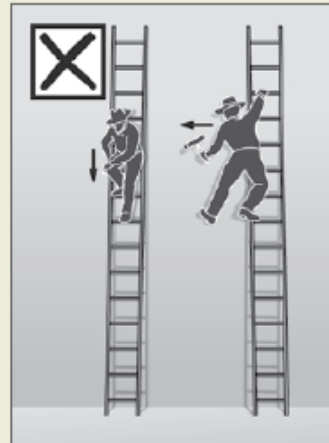

(d) Facing away from the ladder to descend;
over-reaching

Figure 7: Examples of unsafe ladder use

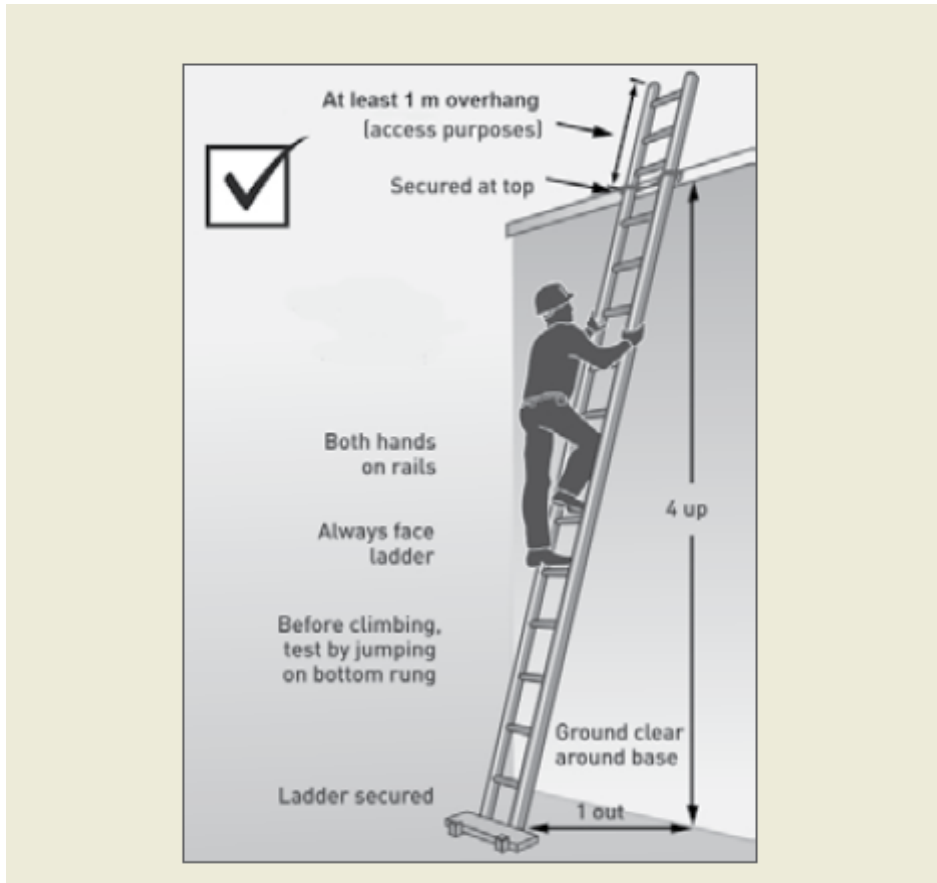

Figure 8: Example of acceptable ladder use

Ladder maintenance

Ladders should be regularly inspected by a competent person. Ladders with any of the following faults must be replaced or repaired:

- timber stiles warped, splintered, cracked or bruised
- metal stiles twisted, bent, kinked, crushed or with cracked welds or damaged feet
- rungs, steps, treads or top plates which are missing, worn, damaged or loose
- tie rods missing, broken or loose
- ropes, braces, or brackets which are missing, broken or worn, and
- timber members which are covered with opaque paint or other treatment that could disguise faults in the timber.

Ladder Checklist

If a ladder is used for short-term light duty work, check that:

- the type of ladder is appropriate to the task. Do not use 'domestic' or 'home-made' ladders. All ladders must comply with the AS/NZS 1892 series and users must follow the manufacturer's/suppliers' recommendations on safe use
- the ladder is in good condition. Before it is used, the ladder should be inspected for faults, such as broken rungs, rails and footing. Consult the manufacturer's/suppliers' checklist, if available
- damaged ladders are removed from service
- the ladder is on firm, stable and level ground
- the ladder is the correct height for the task to avoid reaching or stretching
- the ladder is not too close or too far from the support structure. The ratio must be 4:1. For example, the distance between the ladder base and the supporting structure should be about one metre for every four metres of working ladder height
- the ladder is secured against displacement (i.e. slipping or sliding) and/or there is another person holding the base of the ladder
- the ladder is not placed so that the weight of the ladder and any person using the ladder is supported by the rungs
- all the locking devices on the ladder are secure
- materials or tools are not carried while climbing the ladder. Tools should be carried in a tool belt or side pouch
- only light duty work is undertaken while on the ladder, where three points of contact can be maintained and tools can be operated safely with one hand
- slip resistant base, rungs or steps are provided
- slip resistant shoes are worn
- metal or wire bound ladders are never used close to energised power lines; non-metallic ladders must be used instead
- ladders are not used:
 - in access areas or next to doors
 - on scaffolding or an elevating work platform to get extra height
 - next to power lines
 - in very wet or windy conditions
 - next to traffic areas unless the working area is barricaded.

7.3 Administrative control measures

An administrative control is a system of work or safe work method that minimises the risk of a fall when it is not possible to use a higher order control. An example of this is a requirement that sheet flooring be laid by pushing it out from the centre of the building structure, rather than from the edge.

Administrative control measures are often used to support other fall protection measures.

Administrative control measures may also be used to limit the time workers are exposed to a fall hazard and/or the number of workers involved in the task.

An administrative control should only be used as a means of reducing the risk associated with a particular task. Where it is not reasonably practicable to use a Level 1, 2, 3 or 4 control measure, the following details should be recorded in the SWMS:

- a description of the administrative control used, and
- a description of the task to which the administrative control relates.

It is wise to involve workers in the development of administrative controls. People who perform a task regularly often have a good understanding of the risks involved. However, administrative control measures should not be used simply because they are the lowest cost control.

8. SAFE WORK METHODS FOR COMMON TASKS

This section identifies common tasks in the construction of a typical one or two storey house and describes methods that eliminate or minimise the risk of falls associated with these tasks. Manufacturers/suppliers instructions should be noted prior to commencing tasks. Duty holders may include these instructions in risk assessment documentation.

8.1 Floor laying

In order to construct a solid work area for the construction and/or erection of wall frames, flooring should be laid to ground and upper floors at the earliest opportunity.

Note: Working from open floor joists is an unacceptable work practice for any task.

Stairwells and voids need to be protected prior to floor laying. For further advice see Section 8.3.

Laying flooring is a task that potentially exposes workers to the risk of both internal and external falls. Steep sloping sites increase the potential fall heights.

The laying of floor sheets should begin adjacent to an internal or external access point which provides initial fall protection for workers. Laying of sheets should then proceed using a safe work procedure that prevents workers from falling over the edge, as shown in Figure 9 below. Where the potential fall height is 2 metres or more and a risk assessment has identified the need for physical fall prevention measures and a SWMS to be used for the work, edge protection should be provided.

This may be external scaffolding or guardrailing as shown in Figures 10 and 11. Where strip flooring is to be installed, temporary sheet flooring may be laid and secured as fall protection.

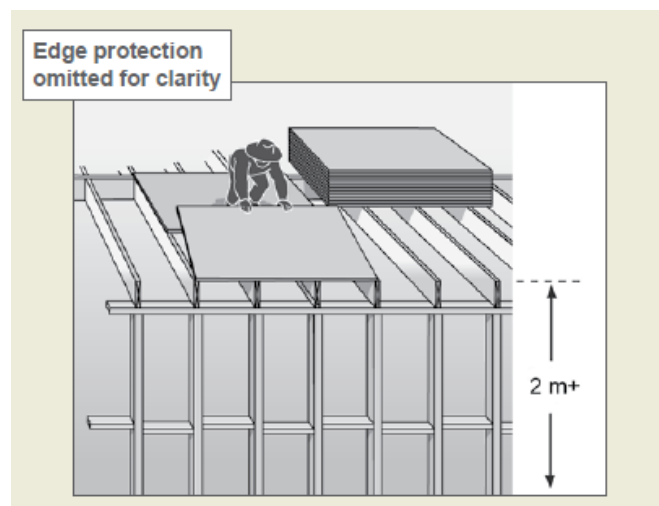

Figure 9: Laying sheet flooring at upper level

Safe access and egress must also be provided to the area where floor is being laid. Access should be restricted to only those workers who are laying the flooring and erecting the wall frames.

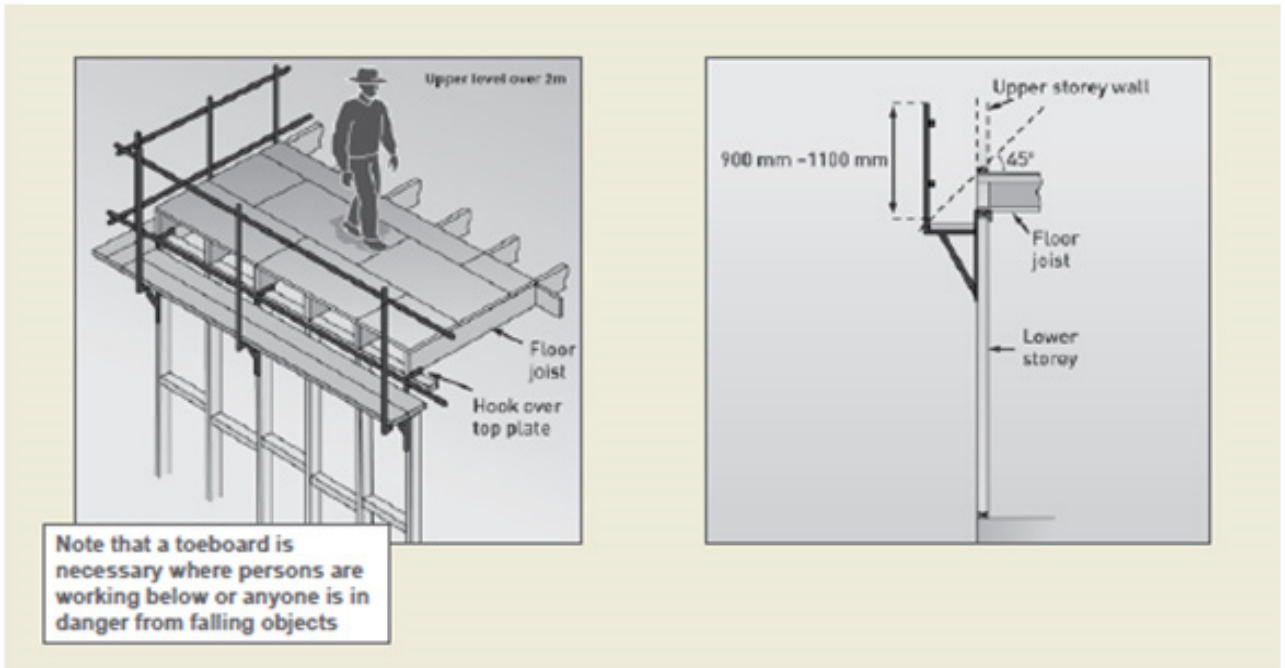

Figure 10: Examples of upper floor edge protection

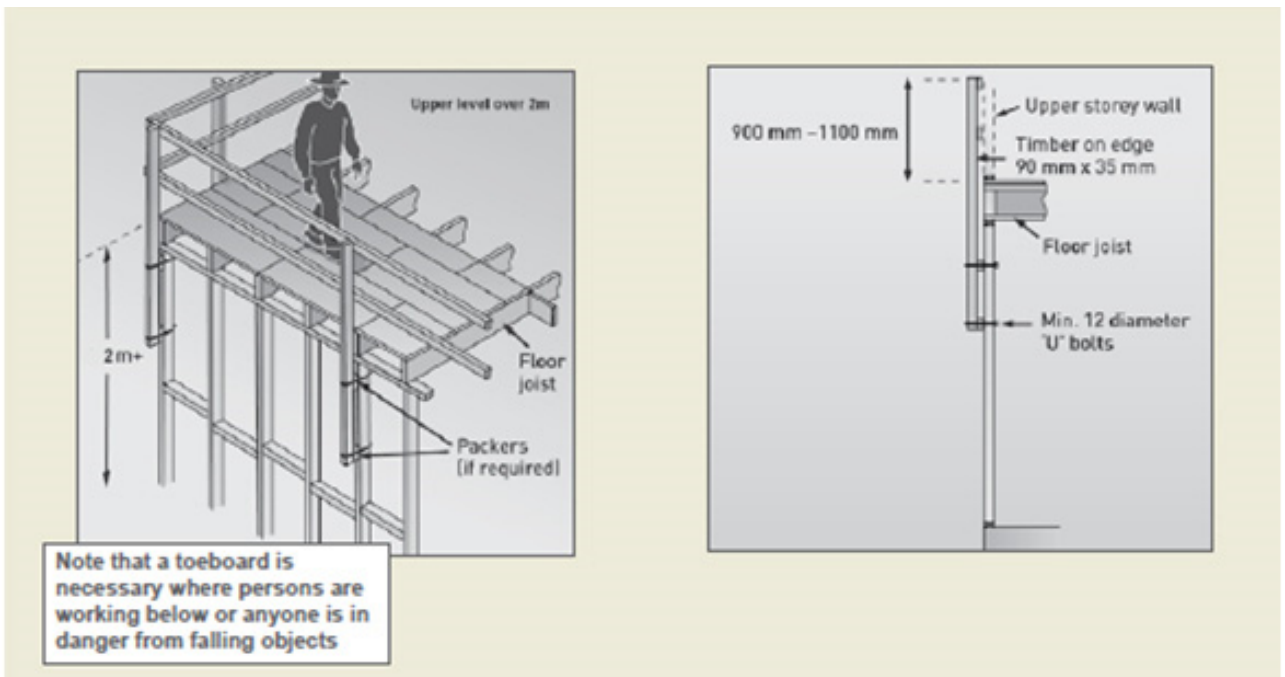

Figure 11: Examples of upper floor edge protection

8.2 Fixing ceiling joists and upper level floor joists

The setting out and nailing of level ceiling joists or upper level floor joists should be done by working off scaffolding set up on the floor below. Trestle scaffolds may be used as shown in Figure 12. Section 4.1 provides further information on the use of trestle scaffolds.

A person may stand on or work from the external top plate if fall protection measures are in place.

Where scaffolds are not suitable, the work may be done using ladders from the floor below.

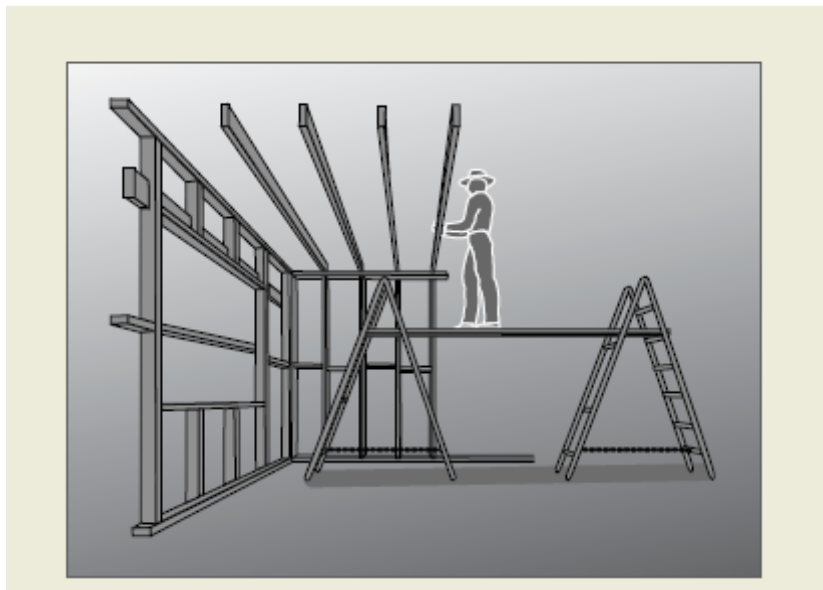

Figure 12: Installing ceiling or upper level floor joists

8.3 Guarding openings

All stairwells, atriums and voids through which a person could fall must be sturdily guarded, covered with an industrial safety net or sheeted over, regardless of the fall distance from the upper level floor. Guardrailing should be provided in accordance with Section 4.1 of this Code. In particular, toeboards should be fitted to prevent tools and materials from being kicked into the void.

Voids and atriums must be guarded as soon as possible after laying sheet flooring, as illustrated in Figure 13.

Where a person working from a stepladder or a working platform, e.g. trestle scaffold or similar may fall over the guardrail and through the opening, the opening must be covered with temporary flooring, timber sheeting, an industrial safety net or similar, even if guardrails have been erected around it.

Any coverings or temporary floors and their supports must be of robust construction capable of withstanding impact loads from any potential falls.

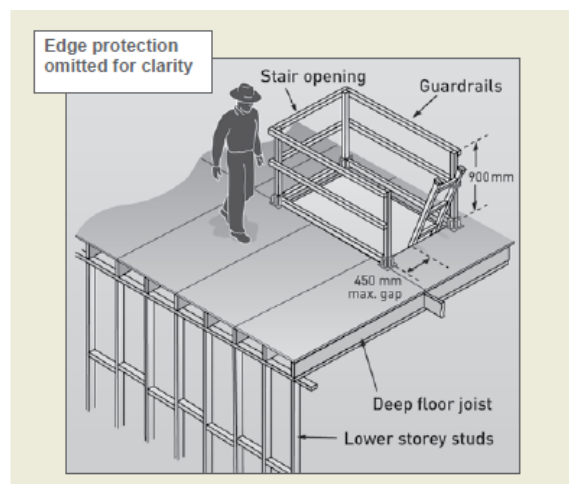

Figure 13: Void at upper level guarded

8.4 Wall framing

Once sheet flooring has been laid and openings have been guarded, work on wall framing may commence. Where the potential fall height for persons constructing or erecting wall frames is 2 metres or more, edge protection must be provided. Window or door openings in external wall frames must be fitted with guardrails prior to raising the frame (see Figure 14). All braces and fixings must be prepared prior to raising the frames. Access to the floor should be restricted to those workers erecting the wall frames.

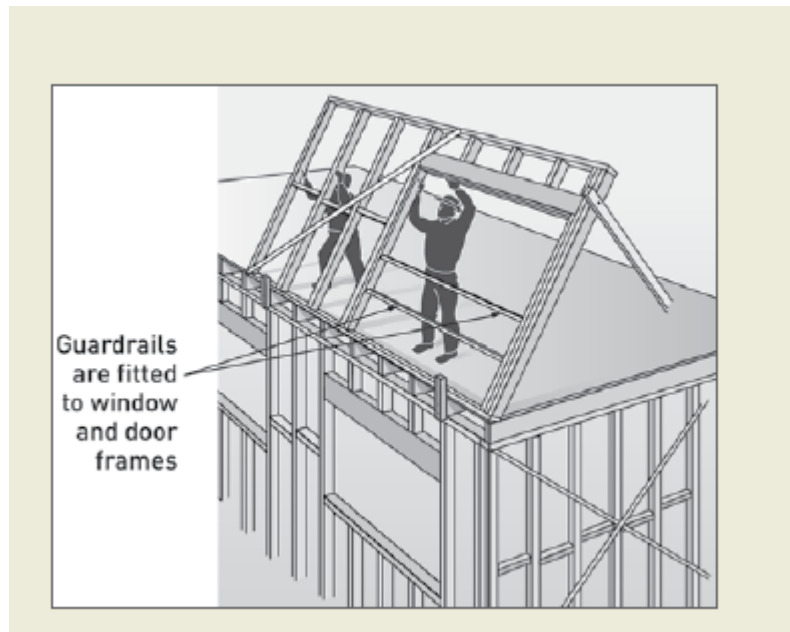

Figure 14: Erecting upper level wall frames

8.5 Installing prefabricated roof trusses

This section provides guidance on safe working procedures for the installation of prefabricated roof trusses.

Preparing for roof truss erection

Where practicable, roof trusses should be placed by crane on the wall top plates at the time of delivery. The truss erector, supplier and transporter should liaise to confirm the order in which the trusses are to be loaded onto the truck. Where possible, the trusses should be able to be unloaded at the site in the order that minimises the amount of handling by the truss erectors. When working at height, the erectors should be able to access the next required truss from the top of the truss stack.

Prior to commencing work ensure that all work areas have safe paths of access and egress at all times, and are free of obstructions.

When working near window penetrations and balconies, ensure all open gaps and penetrations from which a person can fall are protected. Use any of the following methods:

- first floor edge protection system
- timber railings installed at point of manufacture
- temporary stud installed by person erecting roof trusses
- guard railing system

- full perimeter scaffold.

It is important that relevant workers are consulted to ensure that any locations designated for the landing of trusses will not overload the wall frames. The manufacturer/supplier must provide the necessary detail and instructions for the installation of prefabricated timber roof trusses. Where trusses have not been landed directly onto the top plates, a safe system of lifting the trusses to the upper level needs to be developed. At no time must any worker stand on the top plate to receive roof trusses passed up from below.

Lifting roof trusses onto wall frame top plates for erection

The erection of roof trusses involves both internal and external fall hazards.

The erection of trusses may be undertaken from scaffold planks supported on internal wall top plates providing:

- planks are adequately supported across their spans, and
- no person is exposed to the risk of a fall into a stairwell or other void (i.e. a void protection system must be installed).

The person erecting trusses should assess the team's capability to handle the roof trusses. If the size, weight and positioning of the roof trusses pose a risk to the health and safety of the person erecting trusses, then a crane with a certificated operator must be employed to help undertake this task.

Method 1: Where cranning is required when erection height is too great or trusses too large for manual handling:

- the trusses must be craned into position, laid flat and suitably supported prior to erection – where trusses can not be self supporting, use temporary props or internal walls for support (see Figure 15), and
- the person erecting trusses must ensure that all wall frames are adequately braced to withstand loads during construction.

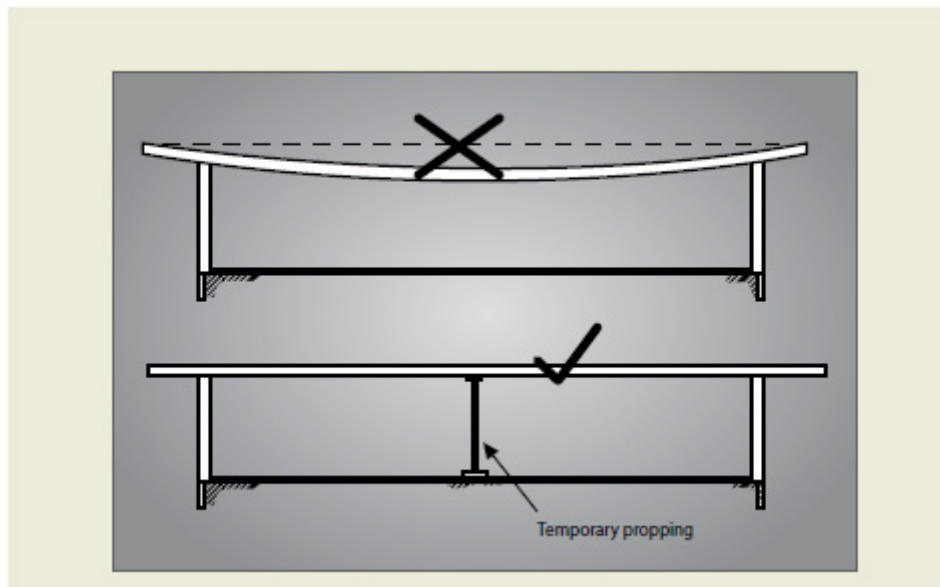

Figure 15: Method of supporting long trusses

Method 2: Where cranning is not required:

- smaller trusses for single storey roofs can be separated from the pack and lifted individually into position along the top plates, or

- if the truss needs to be repositioned, the person erecting the trusses should do this from below to avoid working at heights.

Safe erection methods for roof trusses

At no time is any person to stand on or work from an external wall top plate without suitable fall protection.

The erection of trusses may be undertaken from internal wall top plates or from scaffold planks supported on internal wall top plates providing:

- no person works closer than 1.5 metres to an external wall, including gable end walls
- no person is exposed to the risk of a fall into a stairwell or other void
- planks are adequately supported across their spans.

Note:

- the allowable spans for timber planks are given in Table 1 of section 2.2 Appendix B
- laminated timber, aluminium and steel planks must be used in accordance with the manufacturer's directions

When trusses are erected at up to 600 mm centres, persons working between the trusses to fix or brace them can use the erected trusses as a form of fall protection under controlled conditions as described below. When trusses are erected at greater than 600 mm centres, refer to Section 7.5 for suggested methods of working safely at heights.

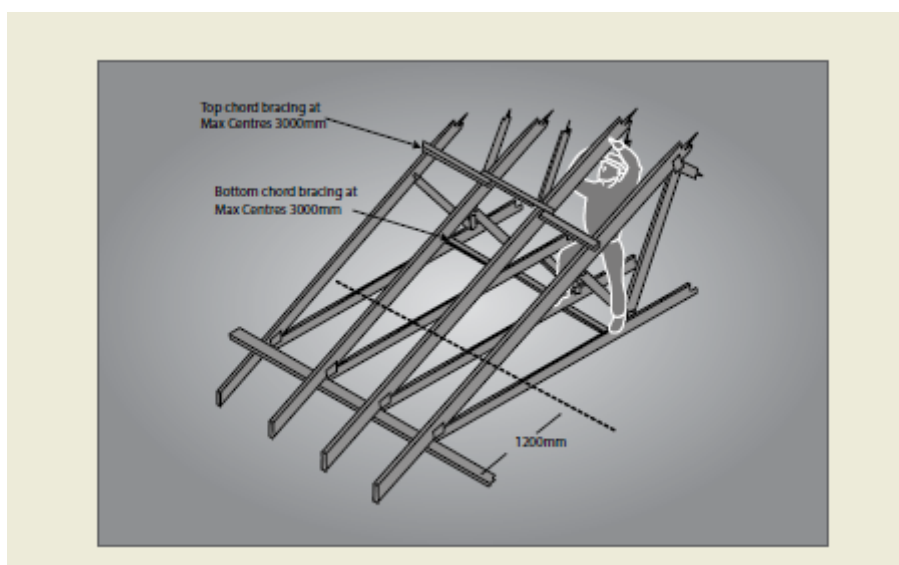

Figure 16: 'No go' zone for persons erecting trusses

Truss bottom chords are considered a safe working area for a competent person if all the conditions below are met.

If the person erecting trusses is to walk or work from the bottom chords of the trusses, the following conditions should be applied:

- trusses are adequately braced to stabilise the structure – bracing must be at a maximum of 3000 mm apart if the bottom chord is used to support the person erecting trusses (see Figure 16)
- only a competent person is to work at heights
- suitable footwear that provides good foothold is to be worn
- a nominated competent person from the truss erection team is to oversee the work
- a competent person or the truss manufacturer/supplier has provided the necessary detail and instructions, including advice in regard to installers standing on the bottom chord, and
- the bottom chord is visually checked by a nominated competent person for defects that may compromise the material's structural integrity (i.e. knots, splits, cracks and rotting timber) before walking on it. If a defect is found, rectification details should be obtained from the truss manufacturer and the person with control must be notified.

If the apex or other high bracing points cannot be reached, use the following method:

- fix waling plates for standing or supporting temporary work platforms at the appropriate height to reach the apex or high points
- the waling plate should be fixed to the face of the truss according to manufacturer's recommendations to ensure the load is transferred to the bottom chord
- the waling plate should be timber of 70 x 35 mm F5, or equivalent, to a maximum of 1500 mm long, fixed at each end by a minimum of two 65 mm x 3.15 mm nails (see Figure 17).

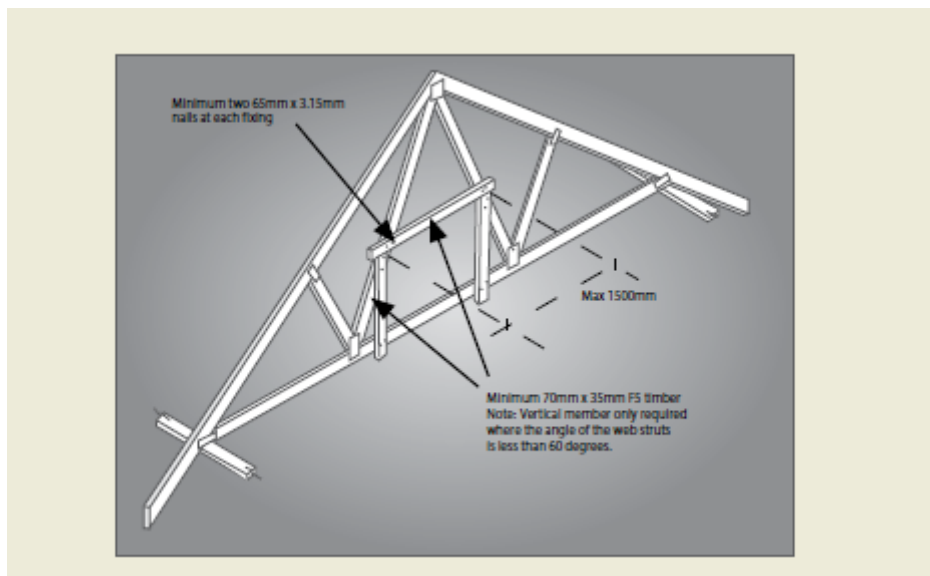

Figure 17: Suggested method of fixing temporary waling plate

- the web strut to support the waling plate should be a minimum 70 x 35 mm F5, or equivalent, fixed at each end by a minimum of two 65 mm x 3.15 mm nails, and
- waling plates should be erected in pairs every fourth truss, or as required, to enable adequate access to fixing points for bracing (see Figure 18).

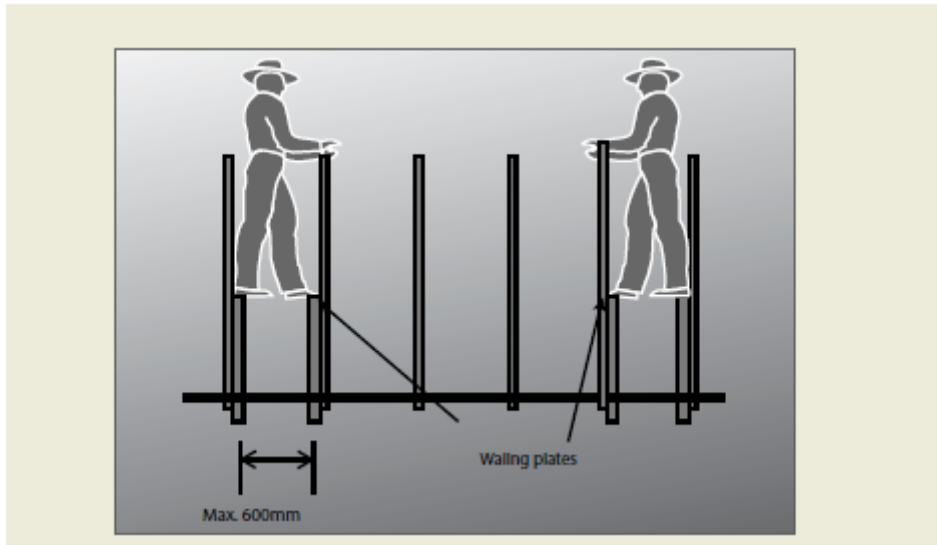

Figure 18: Showing the positions for pairs of waling plates

Erecting first and second trusses

Erect the first truss at the location specified by the roof manufacturer/supplier. This may be repeated a number of times for each common span series of trusses, depending on the roof layout design. Once the first and second trusses are fixed and temporarily braced in, the bottom chord may be used for the person erecting trusses to stand on or to support temporary working platforms.

Note: Where work platforms are used, they must be a minimum of 450 mm wide.

The person erecting trusses should erect, fix and brace the first and second truss in the following manner:

Method 1: Cranage is used to lift and position trusses

- Set up an appropriate working platform with a platform height not greater than 2 metres from the floor level at each end where the truss is to be fixed to the top plate. Alternatively, use a ladder in accordance with Section 7.2. If a perimeter scaffold system is installed this work can be done from the outside rather than using internal working platforms or ladders
- Fix temporary braces to solid fixing points ready for connection to the truss. The braces can be timber of adequate size and length fixed by nails
- Guide the first truss into position while supported by the crane
- Use a minimum of two people, one at each end, to fix the truss to top plates and to the temporary braces. At this point, the first truss should be in a stable condition
- Erect the second truss using the same procedure as above, and
- Temporarily brace the second truss to the first truss.

Method 2: Cranage is not used to lift and position trusses

- Set up an appropriate working platform with a platform height not greater than 2 metres from the floor level at each end where the truss is to be fixed to the top plate.

Alternatively, use a ladder in accordance with Section 7.2. If a perimeter scaffold system is installed this work can be done from the outside rather than using internal working platforms or ladders.

- Fix temporary braces to solid fixing points ready for connection to the truss. The braces can be timber of adequate size and length fixed by nails.
- Fix skid blocks to top plate at first truss position to prevent the truss from slipping during standing.
- Use a minimum of two people, one at each end, to stand the first truss; a third person may be required at mid-span to assist in stabilising a long span truss with a 'v' end push stick (see Figure 19).

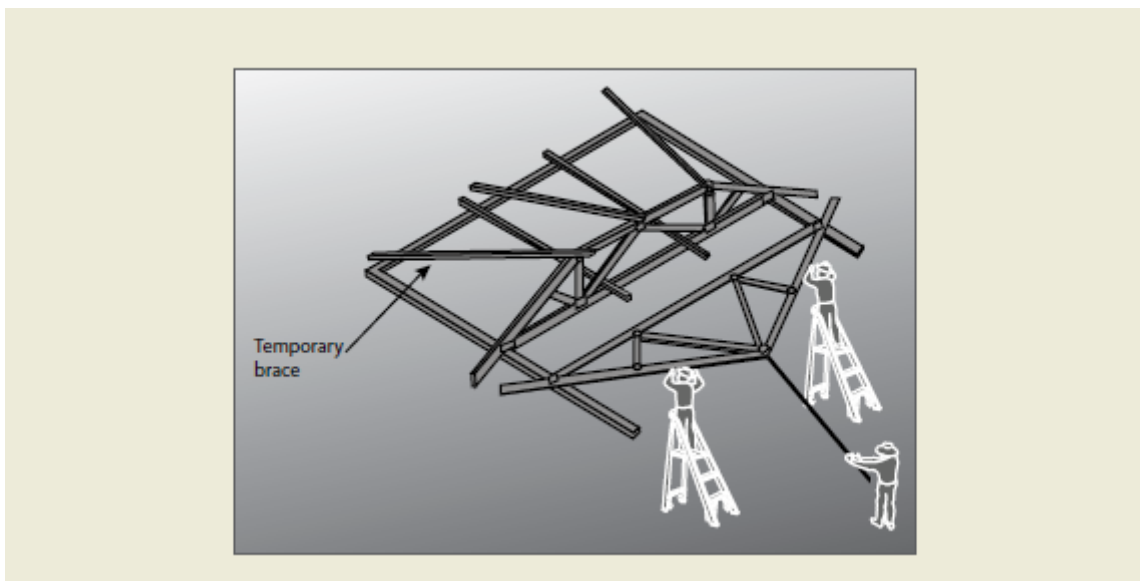

Figure 19: Recommended method of manually standing trusses with a high apex

- After standing the first truss to the vertical position, secure it to temporary braces. At this point, the first truss should be in a stable condition
- Erect the second truss using procedure above, and
- Temporarily brace the second truss to the first truss.

For both method 1 and method 2, the person erecting trusses must inspect the temporary bracing material for obvious defects that may compromise the material's structural integrity (i.e. knots, splits, cracks and rotting timber).

Erecting subsequent roof trusses

Trusses should be taken from the stockpile and moved into position by crane or by the persons erecting them. Additional roof trusses are not to be erected unless the prescribed fixing, bracing and any additional support requirements have been undertaken for the first and second truss.

Each subsequent roof truss should be placed with each end of the truss controlled by a person on the working platform or ladder. A third person at the apex may be required to assist.

Each subsequent roof truss must be fixed and braced according to the manufacturer's/suppliers' specifications using safe methods for working at heights.

Fixing of top and bottom chord temporary bracing

Temporary ties/bracing for roof truss erection should be fixed according to AS 4440. This standard requires that temporary ties be used on the top chords at spacings no greater than 3000 mm and at spacing no greater than 4000 mm on the bottom chord.

If the person erecting trusses is to be supported by the bottom cords of the roof trusses, the ties/bracing must be at spacings no greater than 3000 mm.

All bracing and fixing should take into consideration all imposed loads during the course of construction. As such, flat strapping or an equivalent, or trimmers nailed to the face of trusses where the nailing is from the outer face of the truss, must not be used (see Figure 20).

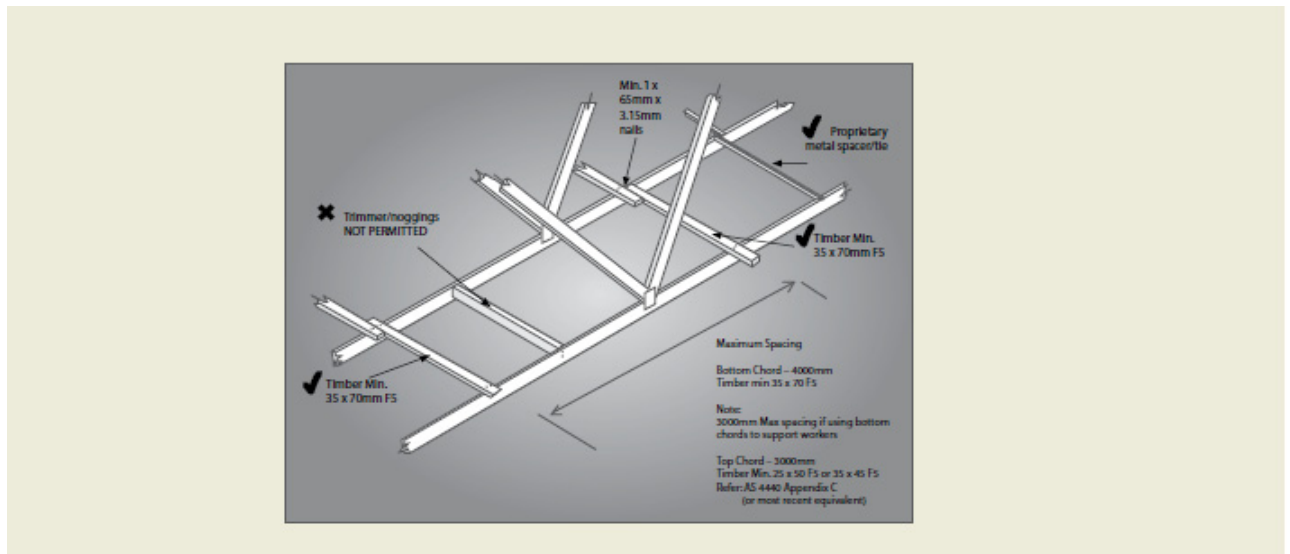

Figure 20: Temporary bracing/ties to bottom chord of trusses. Note: Bracing to top chord similar

Erection of gable roof assembly and verge truss assembly (diminishing truss, verge truss, verge trimmers, gable studs/droppers)

If the erection involves high-risk work (over 2m), it must be carried out in accordance with the requirements of a safe work method statement.

Note that where reasonably practicable, elements of the roof structure, such as a verge sprocket and outriggers, should be pre-assembled on the ground as a complete unit and lifted onto the supporting structure.

Erection of ancillary items

Girder boots, hangers and the like must be installed to the manufacturer's/suppliers' specifications prior to working in the truss space.

The erection should be done using the appropriate safe work methods described in Section 8.8 – *Installation of battens*.

Erecting trusses at greater than 600 mm centres

In certain situations, the spacing of the truss may exceed 600 mm centres, in which case other fall protection must be provided when working at heights to fix and brace the trusses. Such fall protection may include:

- mobile scaffolding system complying with AS 1576 and AS 4576
- mesh or netting installed to the manufacturer's specifications

- fencing and handrails within adjacent trusses installed to the designer's or manufacturer's specifications
- working platforms, elevating platforms, including motorised single person lift platforms complying with AS 1418.10, or
- planks placed across internal and external top plates and across the bottom chords of the truss.

8.6 Constructing conventional or stick roof

Once the ceiling frame has been securely fixed, the ceiling frame may act as a base to install a platform. Planks or sheet flooring plywood can then be used as a platform to pitch the roof. Where additional height is required above the platform on the ceiling frame, an additional platform may be erected.

When constructing a conventional roof, ceiling joists and hanging beams can be passed up internally through a stair opening or externally through the upper level wall frame when it does not expose the receiver to further risk.

Where ceiling joists are erected prior to pitching the rafters, the placement of the ridge beam, and the fixing of rafters to it, may be done from planks or a working deck placed on the ceiling joists. Where ceiling joists are not erected, a work platform will need to be provided for framers to work from.

The practice of roof carpenters balancing on a ceiling hanger while nailing ceiling joists to the hanger is to be avoided where practicable.

Framers working at the external wall should work internally from either scaffolding or ladders or from an external perimeter scaffold. A person can work from an external top-plate if fall protection measures are in place. An external working platform will also provide a work platform for tasks such as trimming rafters and installing eaves.

Where a bracket scaffold system is used, the wall frames should be braced as necessary to ensure adequate strength and to prevent excessive deflection. Scaffold planks may be used from waling plates or across bottom chords or top plates where necessary.

Where feasible, roofing members should be pre-cut at ground level.

8.7 Fixing roof battens to trusses

The process for installation of the roof battens will depend on the types of roofing material that is to be installed. Although there are similarities in the methods used to install metal and tile roofing, there are also differences. Guidelines for the installation of roof battens for each type of roofing material are outlined below. For all roof work physical fall protection at the perimeter of the roof is required (see Section 4.1 – *Perimeter guardrailing*).

Batten and truss spacing

In all cases roof battens need to be capable of supporting the expected loadings from installers.

Note: For dot points 1 and 2 below, battens may be installed in a manner described in Section 8.8 – *Installation of battens*

In addition to the external fall prevention, batten and truss spacing should be reduced to minimise the risk of internal falls:

1. Roof trusses installed and secured at spacings not exceeding 600 mm centres, with batten spacings not exceeding 900 mm centres, or

2. Where roof trusses are installed and secured at spacings greater than 600 mm but not exceeding 900 mm centres, batten spacing must not exceed 450 mm centres, or
3. Where roof truss spacing exceeds 900 mm centres (e.g. 1200 mm) and manufacturers/suppliers instructions permit, intermediate battens must not exceed 450 mm centres. They must also be installed sequentially and in a manner that controls the risk to installers (i.e. install the battens at the eaves first and then work up the roof plane to provide a barrier against falling between the truss rafters), otherwise other fall protection must be used.

8.8 Installation of battens

Marking/setting out for batten positioning

If the trusses are installed at 600 mm centres or less, a person may position the body so that the feet are on adjacent trusses at all times and walk to the apex of the roof in order to mark out measurements.

If trusses are at greater than 600 mm centres, a person should not walk on the top chord of unbattened trusses unless internal fall protection is in place. Marking/setting out should be done sequentially throughout the batten installation process, or by working from a ladder or work platform. If this is not a viable solution, internal fall prevention options such as internal catch platforms, or the use of planks across waling plates, internal top plates and bottom chords should be used.

Installation of battens

Working off a ladder or a working platform, place the battens to be used on top of the trusses or pass/pull them up from the ground. Then secure the lower battens working from a ladder or internal or external work platform prior to roof access being required.

Secure remaining battens sequentially up to the apex of the roof by positioning the body over the truss (see Figure 21) making sure that there is at least one secured batten at waist level or above to minimise the risk of a fall.

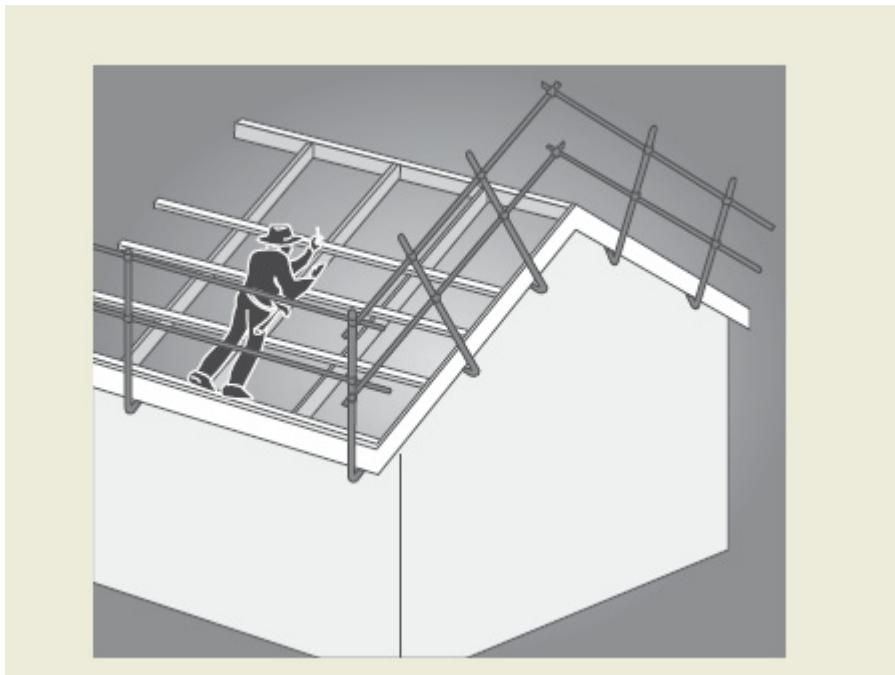

Figure 21: Fixing roof battens to trusses

9. ROOFING TASKS

Roofing work involves several tasks which potentially expose persons to the risk of falls both through and from the edge of the roof structure. Physical edge protection must be provided for all roofing works.

This section gives basic advice on the provision of fall protection for roofing construction work. This Code is not intended as complete guidance where the roofing work involves dismantling or demolition work.

9.1 Risk controls - General

The person with control must assess and control the fall risk of persons undertaking roofing work.

9.2 Critical angle

The pitch of the roof is one of the key risk factors to be considered when determining the type of risk control measures to be put in place for roofing work. The critical angle is the roof pitch below which is considered that roof workers may reasonably be able to work and walk across the roof.

Builders and subcontractors should determine the critical angle as part of their risk assessment. In no case should the critical angle be taken as greater than 26 degrees or 10 degrees where the presence or likelihood of surface moisture, oil or other conditions makes the roof slippery. Consideration should be given to the fact that the critical angle may be reduced in the presence of fully glazed and wet tiles.

9.3 Access and egress

Suitable access must be provided for workers to access the roof to undertake works. This Code requires the access to incorporate the following as appropriate to the edge protection system being used:

- persons must be able to access the roof through the roof edge protection without having to climb over the top rail or midrail
- access ladders must be secured against movement
- where a platform is located more than 500 mm below the roof edge, then additional means of access to the roof must be provided, and
- where an elevator, hoist or similar is used it must be installed so that materials can be received at the roof level.

9.4 Guardrail systems for roofing work

Guardrail systems must include top, mid and bottom rails or toeboards (see Figure 22). Where toeboards are used in place of bottom rails they must be able to withstand the likely impact loads.

The design and testing must comply with the relevant Australian Standards and include the following:

- toeboards or mesh infill to prevent tools, materials or debris falling from the roof, unless a 2 metre 'no go' zone has been established to prevent persons entering the area below
- a clear gap between rails not exceeding 450 mm
- no gap between the roof edge, including the gutter, and a guardrail located outside the roof line exceeding 100 mm
- a clear distance between the roof cladding and the bottom rail of not less than 150 mm and not greater than 275 mm

- an effective guardrail height above the roof surface of not less than 900 mm (for roofs with a pitch over 10 degrees the effective height must be measured from a point 300 mm inside the roof edge), and
- infill panels where the pitch of the roof exceeds 26 degrees.

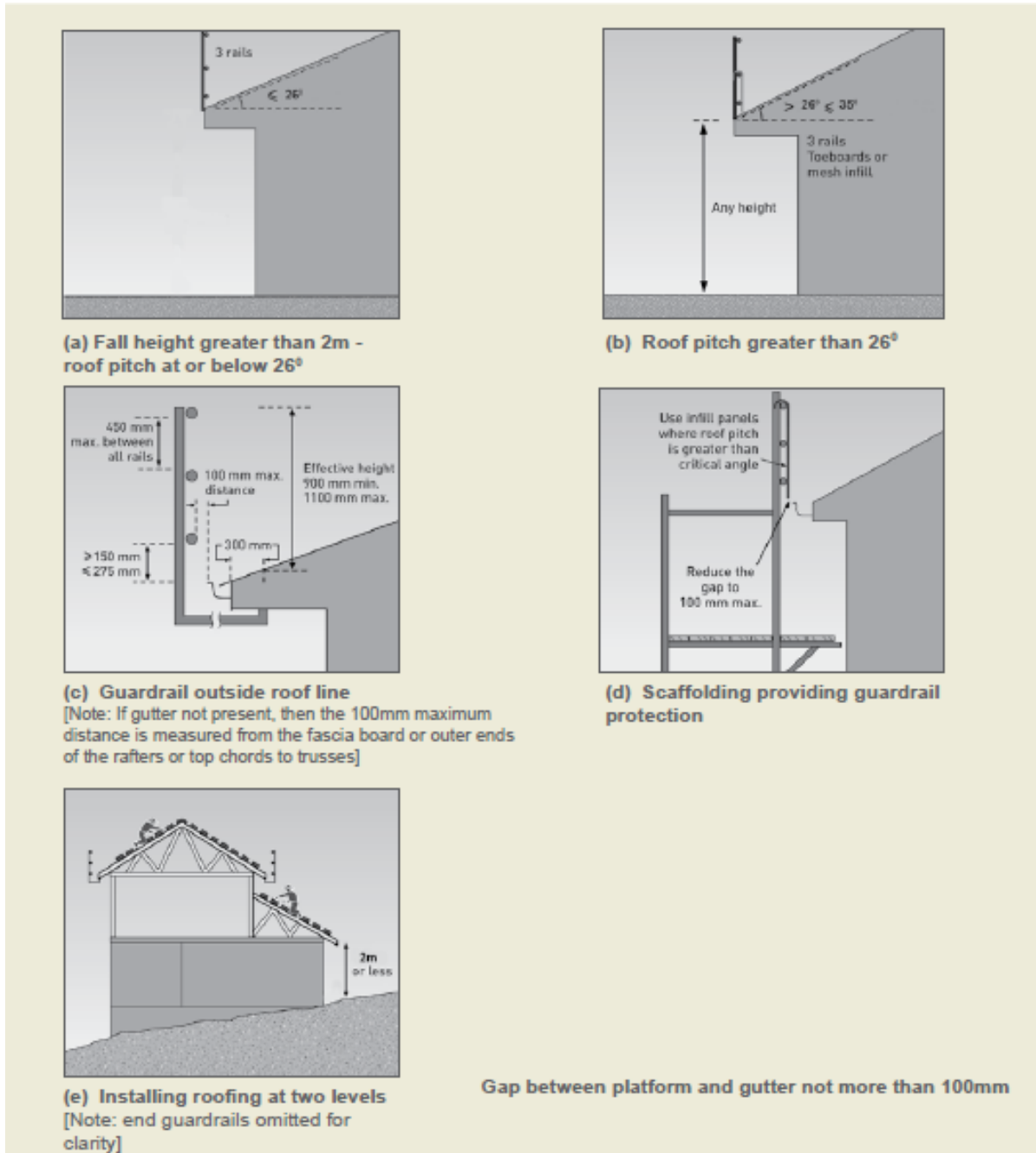

Figure 22: Guardrail system for roofing work.

9.5 Catch platforms

Catch platforms may be constructed from many types of scaffolding systems (see Figure 23). Catch platforms used to control the risk of a fall:

- where the roof pitch is not greater than 26 degrees, should be positioned as close as feasible to the underside of the roof, and in no case greater than 1 metre below the roof edge
- where the pitch of the roof is greater than 26 degrees, should be positioned as close as feasible to the underside of the roof and in no case more than 500 mm below the roof edge
- should have a guardrail, the top rail shall be located at an effective height of not less than 900 mm above the point where the roofline projection intersects the guardrailing, installed with 450 mm midrails
- where there is an increased risk of falling due to slippery roofing materials (such as fully glazed tiles or the presence of dust, moisture or oil on roofing) should be positioned not more than 500 mm below the roof edge, regardless of roof pitch
- should incorporate a toeboard at the platform's outer edge
- should be extended to finish not more than 225 mm from the building face or be fitted with edge protection on the platform's inner edge, and
- should be kept clear of equipment, materials and debris.
- For further information about the protection components refer to AS 4994.

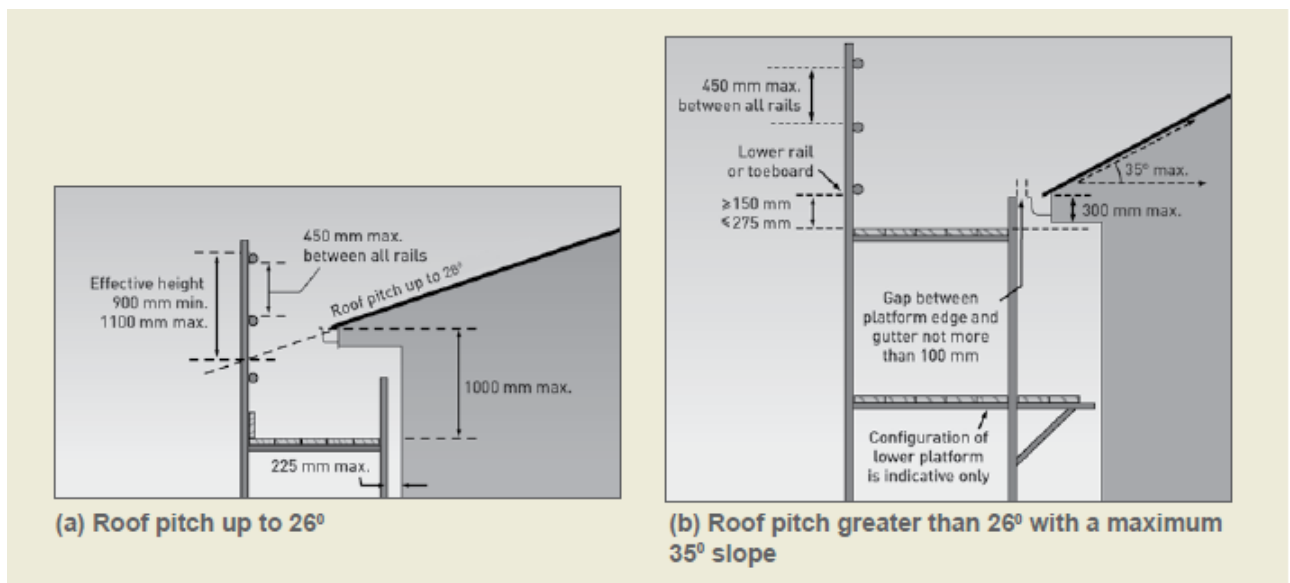

Figure 23: Catch platforms for roofing work

9.6 Steep roofs

Where the slope of a roof exceeds 35 degrees the roof is an inappropriate surface to stand on, even with guardrailing or a catch platform. In these circumstances, roof workers need a system to prevent sliding and to prevent falls from the perimeter, comprising two or more of the following:

- a work positioning system
- a roof ladder, or
- a scaffold platform, located at the roof edge.

9.7 Installation of sarking – tile roofing

If sarking is used the laying of sarking should be done simultaneously with the installation of the battens. Lay the first sheet of sarking and install battens over the sheets, then lay the second sheet and install battens from the bottom of the roof to the apex.

9.8 Installation of perimeter battens – metal roofing

Fastening of the perimeter battens to the hips and valleys may be done by affixing those parts of the perimeter battens which can be easily reached from a position on ladders or from inside the trusses. During the sequential battening of the body of the roof, the remaining length of the perimeter battens can then be secured.

9.9 Fixing fascias and gutters

On houses with no eaves, fascias and gutters may be installed by working from trestle scaffolds or ladders from inside the house frame.

Where the design involves eaves, an external platform must be provided for fascia and gutter installation work. All external work platforms above 2 metres must be at least two planks (450 mm) wide. Guardrailing should be fitted where the fall height is 2 metres or more, or where there are impalement hazards. If a gutter is not present, then the 100 mm maximum distance of the platform from the roof face is measured from the fascia board.

Other control measures for fixing fascias and gutters may include perimeter scaffolds (for two storey construction) and elevated work platforms.

APPENDIX A: REFERENCED DOCUMENTS AND FURTHER READING

Australian Standards	
AS 1418.10	Cranes, hoists and winches – Elevating work platforms
AS/NZS 1576 series	Scaffolding
AS 1577	Scaffolding planks
AS 1657	Fixed platforms, walkways, stairways and ladders – Design, construction and installation
AS 1720.1	Timber structures – Design methods
AS/NZS 1891.1	Industrial fall-arrest systems and devices – Harnesses and ancillary equipment
AS/NZS 1891.3	Industrial fall-arrest systems and devices – Fall-arrest devices
AS/NZS 1891.4	Industrial fall-arrest systems and devices – Selection, use and maintenance
AS/NZS 1892 series	Portable ladders
AS 2550.1	Cranes, hoists and winches – Safe use – General requirements
AS 2550.10	Cranes, hoists and winches – Safe use – Mobile elevating work platforms
AS 2626	Industrial safety belts and harnesses – Selection, use and maintenance
AS 3566.1	Self-drilling screws for the building and construction industries – General requirements and mechanical properties
AS 3623	Domestic metal framing
AS/NZS 4389	Safety mesh
AS 4440	Installation of nailplated timber roof trusses
AS/NZS 4488 series	Industrial rope access systems
AS/NZS 4576	Guidelines for scaffolding
AS/NZS 4994.1	Temporary roof edge protection for housing and residential buildings – General requirements
AS/NZS 4994.2	Temporary roof edge protection for housing and residential buildings – Installation and dismantling

Code of Practice: Managing the Risk of Falls at Workplaces

Code of Practice: Construction Work

National Construction Code of Australia, published by the Australian Building Codes Board

APPENDIX B: TIMBER SCAFFOLDS

B1: INTRODUCTION

This appendix sets out recommended rules for the construction of timber scaffolds for works carried out in connection with buildings or structures and where the vertical distance between the working platform and the lowest level to which a person or object could fall does not exceed 6 metres, and where the scaffold supports no more than one full-length working platform.

All scaffolds must be designed and constructed in accordance with AS/NZS 1576.1. Scaffolds which are constructed in accordance with Section B2 or Section B3 of this appendix are deemed to comply with AS/ NZS 1576.1.

Where it is intended to construct a timber scaffold that does not comply with Section B2 or B3 of this appendix and that has a working platform greater than 2 metres above the lowest level to which a person or object may fall, a copy of the detailed design drawings for the scaffold, prepared by a competent person, should be kept on site.

B2: TIMBER SCAFFOLDS - MAXIMUM 2 METRE LIFT HEIGHTS

2.1 Scaffold components

Load bearing structural members used or intended to be used in the construction of a timber scaffold in accordance with this part, including standards, ledgers, guardrails, midrails, putlogs, braces, ties and rakers, shall have a stress grading of not less than F8 unseasoned hardwood or MGP 12 seasoned pine.

The minimum cross-sectional dimensions of structural members should be as specified in Sections 2.4 to 2.9 in this appendix. The timber sizes listed in this section are the nominal sizes for rough sawn timber. Where this appendix nominates an alternative use of a higher grade seasoned dressed timber, the equivalent dressed size may be used.

All components intended for use in the construction of a timber scaffold must be visually inspected for defects prior to each use and components found to be in an unserviceable condition must not be used.

2.2 Working platform

Working platforms supported by timber scaffolds should be classified as:

- light duty, for loads (persons and materials) of up to 225 kg per bay, or
- medium duty, for loads (persons and materials) of up to 450 kg per bay, or
- heavy duty, for loads (persons and materials) of up to 675 kg per bay.

The minimum width and length of working platforms shall be:

- 450 mm for light duty working platforms
- 900 mm for medium duty working platforms, and
- 1000 mm for heavy duty working platforms.

Planks used or intended to be used in the construction of working platforms should be random planks complying with AS 1577. The maximum spans of solid timber scaffold planks complying with AS 1577 are given in Table 1.

Scaffold planks forming a working platform should:

- be of uniform thickness to prevent trip hazards
- be closely laid across the full width of the scaffold to prevent traps and to prevent material or debris from falling through gaps
- extend beyond their end putlogs not less than 150 mm nor more than 250 mm
- be supported by putlogs at spacings not greater than the maximum spacing marked on the plank
- except at returns or on unusually shaped profiles, be butted rather than lapped
- where necessary, be adequately secured against uplift or displacement.

Nominal thickness of plank (mm)	Maximum span between trestles (m)
32 (hardwood only)	1.0
38	1.5
50	2.0
63	2.5

Table 1 – Maximum span of solid timber scaffold planks complying with AS 1577

2.3 Fixings

Any reference to the use of screws in this section means the use of 10 gauge self-drilling screws complying with AS 3566. Screws must be long enough to have a minimum embedment length of 35mm into the supporting member.

Fixing for ledgers should be not less than:

- one 12 mm diameter mild steel bolt, nut and washer, or
- where the ledger rests on blocking, a 10 mm mild steel bolt, nut and washer. The blocking should be a minimum 200 mm long of the same cross sectional area as the ledger and secured by a minimum of two screws to the standard.

Guardrails, midrails, braces and ties should be fixed with a minimum of two screws.

2.4 Standards

Standards should be vertical and pitched on timber soleplates of sufficient area to distribute imposed loads without observable subsidence.

There should be no cavity under a soleplate immediately below a standard.

Where the height of the scaffold requires joints in the standards, they should be staggered and should not occur:

- in adjacent standards in the same lift
- in the same standard in adjacent lifts
- more than once between adjacent ledgers, or
- more than 300 mm from a ledger.

Joints in standards should be butted and spliced.

The minimum cross-sectional dimensions of standards and the maximum longitudinal and transverse spacing of standards are set out in Table 2.

Minimum nominal size (mm)	Duty classification of working platform	Maximum centre-to-centre longitudinal spacing	Maximum centre-to-centre transverse spacing
75 x 38	Light duty	1.2 m	660 mm
100 x 38	Light duty	2.4 m	1.2 m
100 x 50	Medium duty	2.4 m	1.2 m
100 x 75	Heavy duty	2.4 m	1.2 m

Table 2 – Standards

2.5 Ledgers

Each longitudinal row of standards should be joined on the inside face with horizontal ledgers, with their greater cross-sectional dimension vertical, extending the full length of the scaffold.

The distance between the surface supporting a standard and the first ledger and the distance between vertically adjacent standards should not exceed 2 metres.

The minimum cross-sectional dimensions of ledgers are set out in Table 3.

Joints in ledgers should be butted and spliced. The joints should be staggered and should not occur:

- in horizontally adjacent ledgers in the same bay
- in vertically adjacent ledgers in the same bay
- in the same ledger in the same bay
- in the end bays of a scaffold, or
- more than 300mm from a standard.

Minimum nominal sizes (mm)	Duty classification of working platform
75 x 38	Light duty
100 x 50	Medium duty
100 x 75	Heavy duty

Table 3 – Ledgers

2.6 Putlogs

The scaffold should be fixed in the transverse plane at each lift with putlogs.

Putlogs should be set above ledgers with their greater cross-sectional dimension vertical and shall be securely fixed to the ledgers or standards. Putlogs should be nailed to the upper surface of the ledger to secure them against dislodgement.

At each end of the scaffold, a putlog should be fixed at a distance not greater than 200mm from the edge of the standard. Where the scaffold is two or more bays in length, a pair of putlogs should be fixed, one on either side of the intermediate standards, with the putlog spacing being not greater than 500 mm.

Where the planks of a working platform butt away from the standards, additional putlogs may be required. In any case, the overhang of planks should not be less than 150 mm and not more than 250 mm. In the case of a single pole scaffold, the inside end of each putlog should be fixed to the house frame by a minimum of two screws and should also be seated on minimum 300 mm long timber blocks of the same cross-section, fixed to the frame studs with a minimum of two nails. No joint should occur in the length of a putlog.

The cross-sectional dimensions and the maximum span of putlogs are set out in Table 4.

Minimum sizes (mm)	Duty classification of working platform	Maximum centre to centre span
75 x 38	Light duty	660mm
100 x 50	Medium duty	1.2m
125 x 50	Heavy duty	1.2m

Table 4 – Putlogs

2.7 Bracing

Transverse braces should be fixed diagonally in each lift at each end of the scaffold.

Longitudinal braces should be fixed in each lift of the scaffold to the outside of the outer row of standards, with the distance between braced bays not exceeding three bays in length.

Braces should be fixed diagonally as close as possible to the intersection of the standards and ledgers and, in the first lift, the lower end of a brace should be fixed as close as possible to the intersection of the standard and its soleplate. In the case of a single pole scaffold, the inside end of a transverse brace should be fixed as close as possible to the intersection of a putlog and the building or structure.

Braces should be a minimum of F8 unseasoned hardwood or MGP 12 seasoned pine with cross-sectional dimensions not less than:

- 75 mm x 38 mm for a scaffold supporting a light duty working platform, and
- 100 mm x 50 mm for a scaffold supporting a medium duty or heavy duty working platform.

2.8 Stability

Every scaffold must be effectively stabilised by tying to the building or an adjacent structure, or by rakers to the ground. Ties and rakers should comply with the following:

- except in single pole scaffolds, ties should be fixed to both standards
- rakers should be of the same material as the standards, fixed to the outer standards and, at ground level, they should be firmly footed or fixed with timber stakes driven into the ground, and positioned at approximately 45 degrees to the horizontal
- the first level of ties or rakers should not be higher than 4 metres above the lowest soleplate

- the distance between longitudinally adjacent ties or rakers should not exceed two bays
- ties should not be fixed to the cladding of a building or structure
- ties and rakers should be positioned so as not to obstruct access along the working platform
- no more than one lift should be constructed above the highest level of ties or rakers
- the minimum cross-sectional dimensions of ties should be the same as for braces
- ties and rakers should be continuous in their length.

2.9 Splicing of members

Where members are spliced, such joints should be butt joints with fishplates of the same cross-sectional dimensions fixed equidistant on each side of the butt point, and bolted through with four 12 mm diameter mild steel bolts, washers and nuts, spaced at 225 mm centres.

2.10 Working platform edge protection and access

Working platforms must be provided with edge protection and a safe means of access and egress. Further guidance is available in AS/NZS 4576.

B3: TIMBER SCAFFOLDS – SINGLE POLE WITH HIGH FIRST LIFT HEIGHT

This section provides guidance for single pole scaffolds with:

- a first lift height of up to 6 metres
- a maximum load rating of medium duty

These scaffolds are typically suitable for many work tasks in the construction of double storey extensions, including the fixing of cladding, general carpentry, rendering and painting. Scaffolds prescribed in this section are not suitable for heavy duty works such as bricklaying.

3.1 Configuration

The configuration of scaffolds prescribed in this section is shown in Figure 26.

For scaffolds erected in accordance with this section the primary loads are transferred directly from the working platform to the putlogs at each standard. These putlogs transfer the loads directly to the standard at the outer face and to the building frame at the inner face. Intermediate putlogs, supported by a ledger, are only required where it is necessary, to ensure planks do not exceed their allowable span or where planks are butted along the working platform.

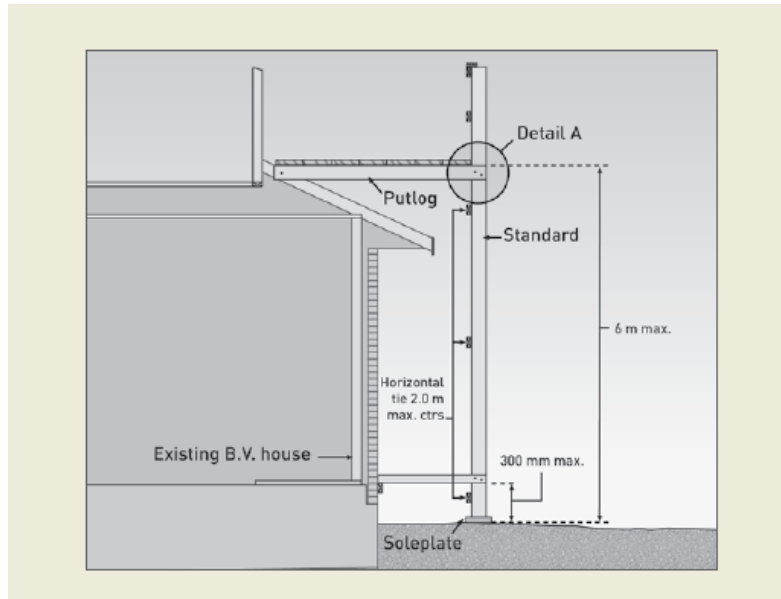

Figure 26: Timber scaffold (single pole – high first lift)

3.2 Scaffold components

Load bearing structural members used or intended to be used in the construction of a timber scaffold in accordance with this section, including standards, guardrails, midrails, putlogs, braces, ties and rakers, should have dimensions and stress gradings as specified in Sections 3.5 to 3.9.

All components intended for use in the construction of a timber scaffold should be visually inspected for defects prior to each use and components found to be in an unserviceable condition must not be used.

3.3 Working platform

Working platforms supported by timber scaffolds constructed in accordance with this section are classified as:

- light duty, for loads (persons and materials) of up to 225 kg per bay, or
- medium duty, for loads (persons and materials) of up to 450 kg per bay.

3.4 Fixings

Any reference to the use of screws in this section means the use of Type 17 self drilling screws complying with AS 3566. Screws must be long enough to have a minimum embedment length of 35 mm into the supporting member.

All fixings for ledgers, horizontal ties, putlogs and braces should be not less than 2 nos 12 gauge screws to each standard.

Putlogs at each standard should bear directly on the standard and be fixed to the standard as shown in Figure 27. The inside end of these putlogs should be fixed to the building rafter with minimum one M12 bolt. Intermediate putlogs should be nailed to the upper surface of the ledger to secure them against dislodgement.

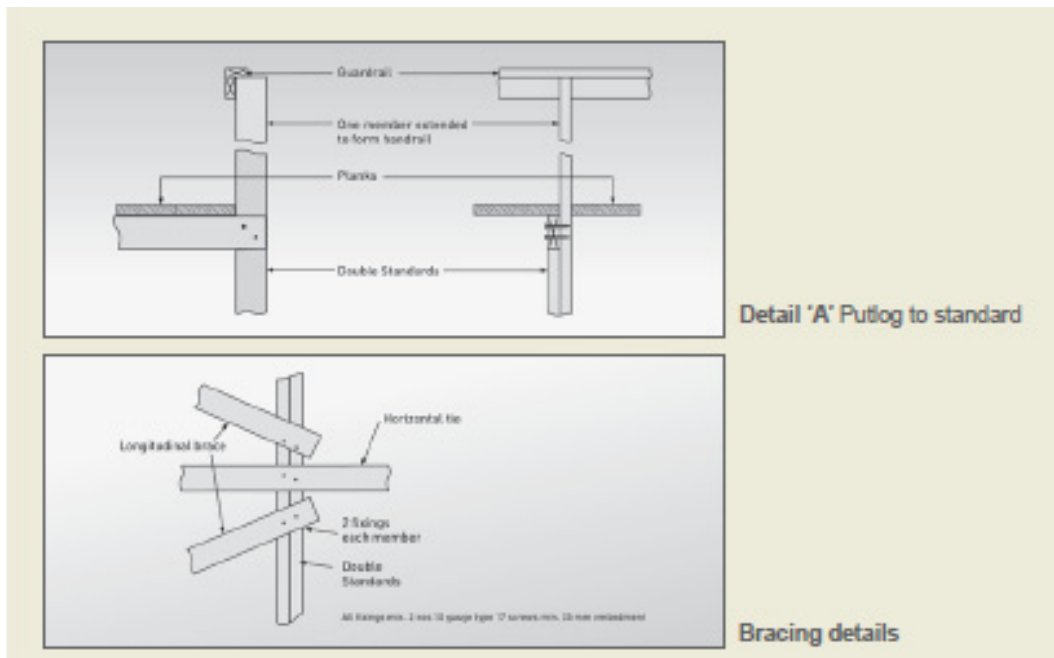

Figure 27: Timber scaffold (single pole – high first lift) details.

3.5 Standards

Standards should have a stress grading not less than:

- F8 unseasoned hardwood, or
- MGP 12 seasoned pine.

The minimum cross-sectional dimensions and should be in accordance with Table 5.

The maximum longitudinal spacing of standards should be 2.7 metres.

Except as noted in this section, standards should be constructed in accordance with Section 2.4 of this appendix.

Height to working platform	Minimum (nominal) sizes
6.0 m	2 nos 120 x 45
5.0 m	2 nos 120 x 45
4.0 m	2 nos 90 x 45
3.0 m	2 nos 90 x 45

Table 5 – Standards

3.6 Ledgers and horizontal ties

Each longitudinal row of standards should be joined on the inside face with horizontal ties with their greater cross-sectional dimension vertical, extending the full length of the scaffold. At the working platform a ledger should perform the function of a horizontal tie.

All horizontal ties should be:

- a minimum size of 70 x 45 or 90 x 35 MGP 10 seasoned pine

- located at a maximum centre to centre vertical spacing of 2 metres with the lowest tie being not greater than 300 mm above the sole plate.

A ledger of minimum size 120 x 35 F17 KDHW should be fixed to the inside of each standard at the level of the working platform. Joints in ledgers and horizontal ties should be staggered and should not occur:

- in vertically adjacent members in the same bay
- in the same member in the same bay, or
- in the end bays of a scaffold.

Joints in ledgers and horizontal ties should be butted and spliced.

3.7 Putlogs

The scaffold should be fixed in the transverse plane at the working platform lift. In this type of scaffold design the putlogs also perform the function of tying the scaffold to the building. Putlogs should be:

- located at each standard
- fixed to their support in accordance with Section 3.4 of this appendix
- be continuous along their length.

The cross-sectional dimensions and the maximum span of putlogs are set out in Table 6.

Span of putlog	Minimum sizes and grading
2.4 m	140 x 45 F17 KDHW
1.8 m	140 x 45 F17 KDHW
1.2 m	150 x 50 F7 Oregon

Table 6 – Putlogs

3.8 Bracing

Longitudinal braces should be fixed in each lift of the scaffold to the outside of the outer row of standards, with the distance between braced bays not exceeding three bays in length.

Braces should be fixed diagonally as close as possible to the intersection of the standards and ledgers and, in the first lift, the lower end of a brace should be fixed as close as possible to the intersection of the standard and its soleplate.

Braces should be a minimum of F8 unseasoned hardwood or MGP 10 seasoned pine with nominal cross-sectional dimensions not less than 100 x 38 mm.

3.9 Splicing of members

Where members are spliced, such joints should be butt joints with fishplates of the same cross-sectional dimensions fixed equidistant on each side of the butt point, and bolted through with four 12mm diameter mild steel bolts, washers and nuts, spaced at 225 mm centres.

3.10 Working platform edge protection and access

Working platforms must be provided with edge protection and a safe means of access and egress. Further guidance is available in AS/NZS 4576.